

1

PENDANT  
PLUSMINUS  
FLOOR & TABLE

2

CEILING  
WALL  
OUTDOOR



VIBIA

# Better Spaces, Better Lives

Vibia exists to create beautiful **atmospheres** that enhance **wellbeing**.

We put **people at the centre** of everything we do; we aim to improve lives by helping professionals create better spaces for everyone to enjoy. This purpose is **shared across the entire space-design ecosystem**.



# Shaping Atmospheres

We aim to lead a new approach to lighting focused on **people's emotions**, elevating interior design as a fundamental discipline for the cultivation of **wellbeing**.

We propose a new approach to designing **emotional atmospheres** based on the creation of specific **scenes** according to the use of a space over time, integrating dynamic light and advanced **control system** design. To support this, we offer a holistic product portfolio that provides a unique blend of lighting effects.

Relaxation



Activation



Concentration



Socialisation

## Elevating Interior Design



Interior design is fundamental to the cultivation of **wellbeing**.



The designer's job is to create beautiful spaces that **generate positive emotions**. This begins with an understanding of how the human brain perceives sensory cues and the influence they have on our emotional response to a space.

The inter-relationship between the physical and spatial elements, the texture, form and composition of objects, the interior design, and the light, all depend on the specific atmosphere we want to achieve.

## Vibia Portfolio: A Holistic Approach



Creating scenes of wellbeing through a **unique blend of lighting effects**



Diffuse



Indirect

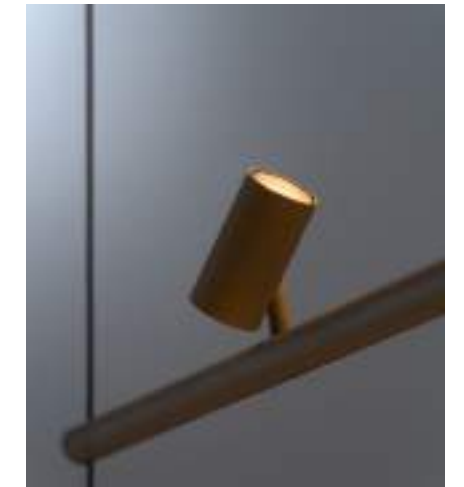

Direct

We combine different lighting typologies with different levels of density, experimenting with a synthesis of **diffuse**, **indirect** and **direct** light to create the perfect ambience at any time of day.

# Creating scenes of wellbeing with dynamic light

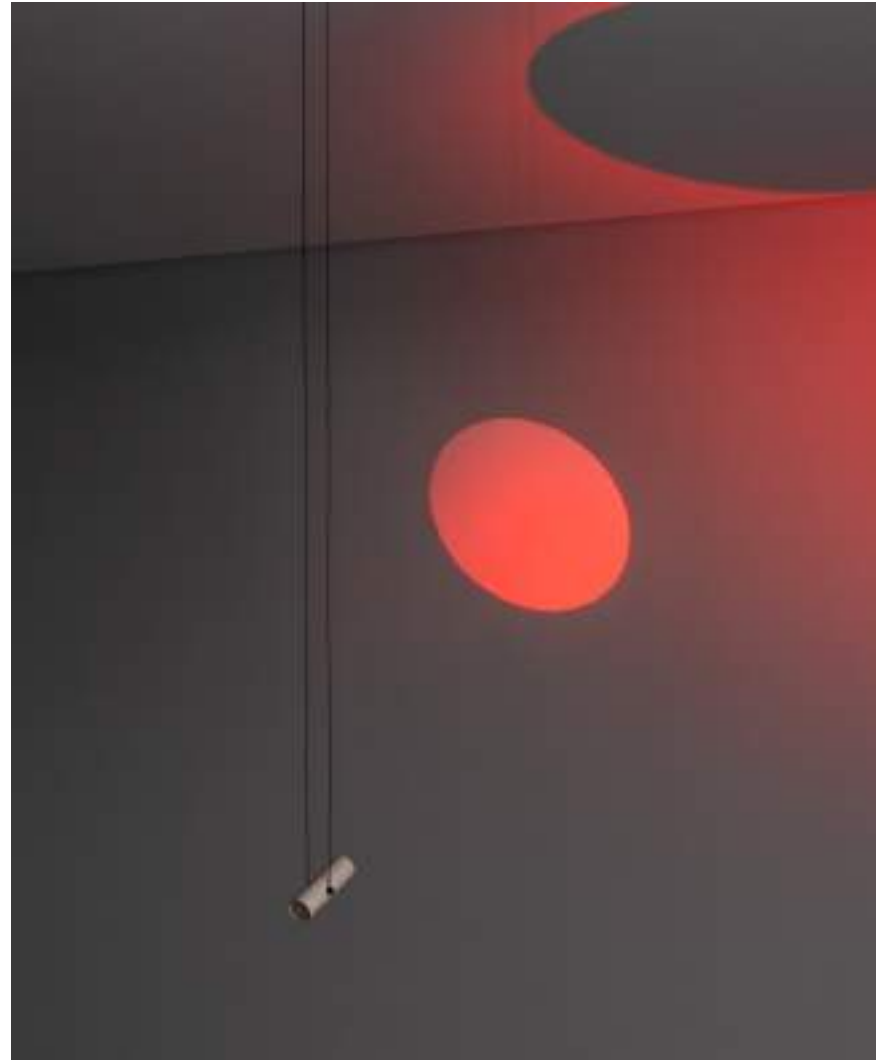

Dynamic light allows professionals to play with **subtle degrees of intensity and colour** to recreate an ambience for every scene within a lighting project.

## Comfortable Environments

Vibia's spot accent, downlight and general lighting luminaires include the option of tunable white. Tunable lighting allows for comprehensive colour temperature and intensity regulation depending on the desired atmosphere for every scene. Combining tunable white lights with diffuse and indirect lighting effects allows you to design the perfect scene for every moment or use.

## Chromatica Colours of Light

Natural light is never mono-tonal. Vibia's approach to the use of coloured light and gradients is to create beautiful atmospheres that are as natural and subtle as possible.

### Static White

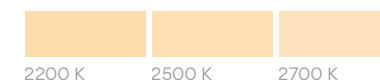

### Tunable White





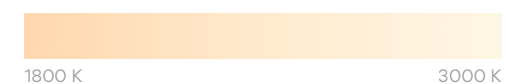



### Dim-To-Warm



### Tunable Red



### Colour Moods

-  **Still** - A pale and thin green light, inspired by the very first rays of morning sun
-  **Vivid** - A vibrating blue with a hint of pale yellow for a feeling of liveliness
-  **Delicate** - A warm and glowing orange-yellow hue, reminiscent of afternoon sun spilling through the window
-  **Cozy** - Bringing a glowing warmth, this orange-red hue contains darker, moodier undertones
-  **Intense** - A powerful and bold red. Not just a striking colour, but deep and nuanced
-  **Illusive** - An alluring and intriguing blue light that lends an energised, almost magical feel to a space

# Sustainable Development

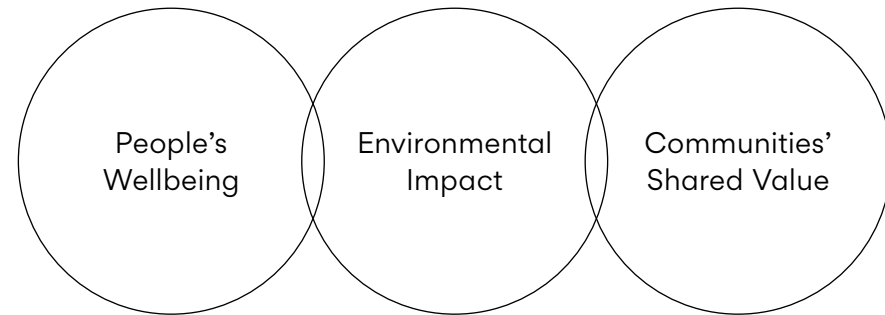

By creating better spaces we contribute to individual wellbeing, minimising our environmental impact on the planet and generating shared value across all our communities.

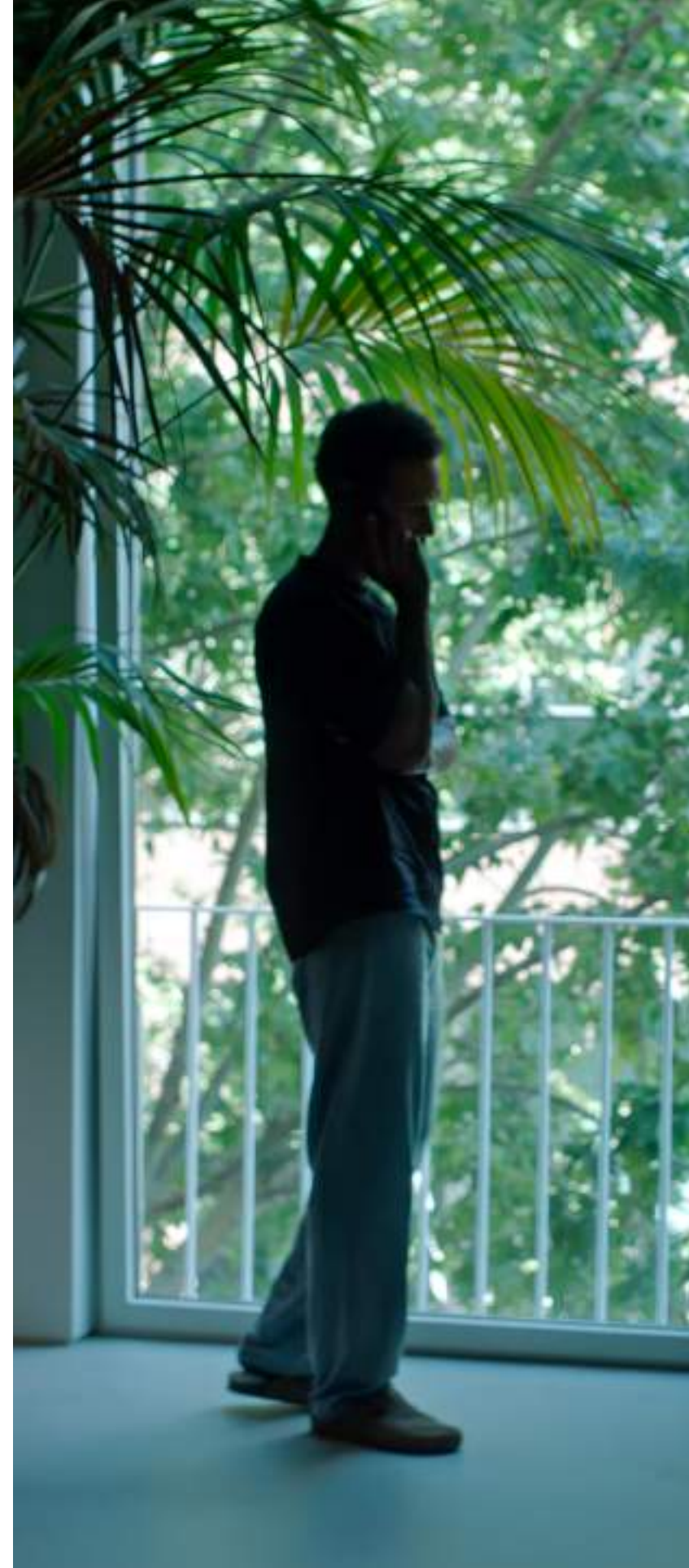

## People's Wellbeing

### Atmospheres of Wellbeing

We aim to introduce a new approach to lighting based on the **creation of atmospheres** that foster wellness and enrich people's lives.

### Decoding Emotion

This starts with an understanding of how the human brain perceives sensory cues, decoding and maximising the **emotional impact** of a space.

### Exploring Space Usage

We explore how individuals will **use a space** and design adaptable, hybrid scenes to accommodate their needs over time.

### Dissemination of Knowledge

We contribute to the **elevation of interior design** as fundamental to the cultivation of wellbeing and to the dissemination of knowledge in the creation of atmospheres of wellbeing.



# Minimising our Environmental Impact

## Eco Design and Circularity

We are committed to design that lasts, minimising the amount of material and maximising the use of natural, recycled and recyclable materials. Reusability, sustainable packaging, installation, replaceability and disassembly are essential elements of our designs. This approach significantly reduces waste generation and supports the principles of a **circular economy**.

## Decarbonisation

Our decarbonisation strategy focuses on **reducing our carbon footprint** by setting emission targets, minimising travel impact **through digitalisation** across the customer journey, and prioritising the **use of renewable energy**.

## Energy Saving

Our environmental commitment involves **reducing energy consumption** by integrating energy-efficient components, controls, and systems that enhance lighting efficiency and quality.



# Shared Value with Our Communities

## Professional Space Design Community

Vibia fosters collaboration and co-creation within the space-design ecosystem, providing both digital and physical support services to ensure a **seamless customer journey**.

## Vibia: The Place to Be

Our team of employees and collaborators comprises experts with diverse industry knowledge, fostering an inclusive, diverse, and **collaborative culture**.

## Responsible Ecosystem

Our approach to responsible business practices includes corporate compliance, adherence to sustainability standards, recognitions in Environmental, Social, and Governance (ESG) criteria, and partnerships with **ESG-compliant suppliers**.

## Social Commitment

We actively engage with local communities, promoting **social responsibility**, providing **education** and professional training opportunities, and **creating better spaces** for everyone to enjoy.

|        |   |                     |     |
|--------|---|---------------------|-----|
| Volume | 1 | Pendant             | 1   |
|        |   | Plusminus           | 271 |
|        |   | Floor & Table       | 355 |
|        |   | Lighting Typologies | 486 |
|        |   | Support Portfolio   | 490 |
|        |   | Item index          | 492 |
|        |   | Acknowledgements    | 495 |

|        |   |                     |     |
|--------|---|---------------------|-----|
| Volume | 2 | Ceiling             | 1   |
|        |   | Wall                | 209 |
|        |   | Outdoor             | 359 |
|        |   | Lighting Typologies | 472 |
|        |   | Support Portfolio   | 476 |
|        |   | Item index          | 478 |
|        |   | Acknowledgements    | 481 |

# Collections

## Africa

**Floor & Table**  
Vol1 356

## Algorithm Free

**Pendant**  
Vol1 200

## Algorithm Grid

**Pendant**  
Vol1 206

## Alpha

**Wall**  
Vol2 316

## Array

**Pendant**  
Vol1 2

## Balance

**Floor & Table**  
Vol1 400

## Bamboo

**Outdoor**  
Vol2 414

## Bigger

**Pendant**  
Vol1 176  
**Ceiling**  
Vol2 202

## Bind

**Pendant**  
Vol1 240  
**Ceiling**  
Vol2 128

## Bind Solo

**Ceiling**  
Vol2 148

## Break

**Outdoor**  
Vol2 430

## Break Plus

**Outdoor**  
Vol2 435

## Brisa

**Outdoor**  
Vol2 402

## Circle

**Ceiling**  
Vol2 18

## Circus

**Pendant**  
Vol1 32  
**Ceiling**  
Vol2 42

## Circus Solo

**Pendant**  
Vol1 56  
**Ceiling**  
Vol2 62

## Class

**Outdoor**  
Vol2 456

## Cosmos

**Pendant**  
Vol1 160

## Dama

**Pendant**  
Vol1 20  
**Floor & Table**  
Vol1 364

## Dots

**Wall**  
Vol2 242

## Dots Glass

**Wall**  
Vol2 252  
**Outdoor**  
Vol2 372

## Dots Outdoor

**Outdoor**  
Vol2 360

## Duo

**Ceiling**  
Vol2 2

## Duo Petra

**Ceiling**  
Vol2 12

## Empty

**Outdoor**  
Vol2 408

## Flamingo

**Pendant**  
Vol1 154

## Flamingo Mini

**Pendant**  
Vol1 144

## Flat

**Pendant**  
Vol1 94  
**Floor & Table**  
Vol1 405  
**Ceiling**  
Vol2 68

## Funnel

**Ceiling**  
Vol2 172  
**Wall**  
Vol2 300

## Ghost

**Pendant**  
Vol1 90  
**Floor & Table**  
Vol1 438

## Guise

**Pendant**  
Vol1 110  
**Ceiling**  
Vol2 168  
**Wall**  
Vol2 288

## Halo

**Pendant**  
Vol1 218  
**Wall**  
Vol2 336

## Halo Jewel

**Pendant**  
Vol1 224

## I.Cono

**Floor & Table**  
Vol1 424  
**Wall**  
Vol2 308

## Jazz

**Floor & Table**  
Vol1 444

## June

**Outdoor**  
Vol2 446

## Knit

**Pendant**  
Vol1 26  
**Floor & Table**  
Vol1 378

## Kontorno

**Pendant**  
Vol1 80  
**Wall**  
Vol2 278

## Lily

**Pendant**  
Vol1 14  
**Floor & Table**  
Vol1 372

## Line

**Ceiling**  
Vol2 76

## Match

**Pendant**  
Vol1 166

# Collections

## Mayfair

**Pendant**  
Vol1 194  
**Floor & Table**  
Vol1 394

## Mayfair Mini

**Floor & Table**  
Vol1 388

## Meridiano

**Outdoor**  
Vol2 450

## Musa

**Floor & Table**  
Vol1 454  
**Wall**  
Vol2 296

## North

**Pendant**  
Vol1 264  
**Floor & Table**  
Vol1 412  
**Wall**  
Vol2 330

## Offset

**Floor & Table**  
Vol1 460  
**Ceiling**  
Vol2 94  
**Wall**  
Vol2 348

## Origami

**Wall**  
Vol2 312  
**Outdoor**  
Vol2 388

## Out

**Floor & Table**  
Vol1 468  
**Outdoor**  
Vol2 378

## Palma

**Pendant**  
Vol1 170  
**Ceiling**  
Vol2 116  
**Wall**  
Vol2 256

## Palo Alto

**Outdoor**  
Vol2 394

## Pin

**Floor & Table**  
Vol1 418  
**Wall**  
Vol2 262

## Plusminus

**Plusminus**  
Vol1 271

## Plusminus Solo

**Floor & Table**  
Vol1 472  
**Ceiling**  
Vol2 120  
**Wall**  
Vol2 216

## Puck

**Ceiling**  
Vol2 192  
**Wall**  
Vol2 320

## Puck Wall Art

**Wall**  
Vol2 324

## Rhythm Horizontal

**Pendant**  
Vol1 182

## Rhythm Vertical

**Pendant**  
Vol1 188

## Set

**Wall**  
Vol2 274

## Skán

**Pendant**  
Vol1 116  
**Floor & Table**  
Vol1 434

## Slim

**Pendant**  
Vol1 212

## Spa

**Ceiling**  
Vol2 182  
**Wall**  
Vol2 232

## Sticks

**Pendant**  
Vol1 66  
**Wall**  
Vol2 340

## Sticks Solo

**Pendant**  
Vol1 384  
**Floor & Table**  
Vol1 384

## Structural

**Ceiling**  
Vol2 176  
**Wall**  
Vol2 268

## Suite

**Floor & Table**  
Vol1 430  
**Wall**  
Vol2 304

## Tempo

**Pendant**  
Vol1 234  
**Wall**  
Vol2 226

## Top

**Ceiling**  
Vol2 36  
**Wall**  
Vol2 210

## Tube

**Pendant**  
Vol1 106

## Tube Free

**Pendant**  
Vol1 100  
**Ceiling**  
Vol2 196

## Up

**Ceiling**  
Vol2 188

## Warm

**Pendant**  
Vol1 122  
**Floor & Table**  
Vol1 448

## Wind

**Pendant**  
Vol1 230  
**Outdoor**  
Vol2 422

## Wireflow

**Pendant**  
Vol1 126

## Wireflow Chandelier

**Pendant**  
Vol1 140

## Wireflow Free

**Pendant**  
Vol1 134

## Wireflow Lineal

**Pendant**  
Vol1 130

Pendant

# Pendant

|                          |                      |                             |                               |
|--------------------------|----------------------|-----------------------------|-------------------------------|
| Algorithm<br>Free<br>200 | Flat<br>94           | Palma<br>170                | Tube<br>Free<br>100           |
| Algorithm<br>Grid<br>206 | Ghost<br>90          | Rhythm<br>Horizontal<br>182 | Warm<br>122                   |
| Array<br>2               | Guise<br>110         | Rhythm<br>Vertical<br>188   | Wind<br>230                   |
| Bigger<br>176            | Halo<br>218          | Skam<br>116                 | Wireflow<br>126               |
| Bind<br>240              | Halo<br>Jewel<br>224 | Slim<br>212                 | Wireflow<br>Chandelier<br>140 |
| Circus<br>32             | Knit<br>26           | Sticks<br>66                | Wireflow<br>Free<br>134       |
| Circus<br>Solo<br>56     | Kontorno<br>80       | Sticks<br>Solo<br>74        | Wireflow<br>Lineal<br>130     |
| Cosmos<br>160            | Lily<br>14           | Tempo<br>234                |                               |
| Dama<br>20               | Match<br>166         | Tube<br>106                 |                               |
| Flamingo<br>154          | Mayfair<br>194       |                             |                               |
| Flamingo<br>Mini<br>144  | North<br>264         |                             |                               |

# Array



Design by Umut Yamac.

A striking pendant of impressive proportions, Array is an exploration of thread and its potential to create lightweight and dynamic sculptures of light.



Composed of an array of fine technical threads pulled taut between two aluminum rings, Array presents a wide range of conical and cylindrical silhouettes that can be combined together to form a compelling installation.

The spacing distribution of the threads creates translucency and volume, whilst the layering effect gives the illusion of movement. Suspended overhead, Array emits a pleasant downlight projected from an invisible source concealed within the lower ring.

At the same time, indirect light washes upwards in a gradient of colour, enveloping rather than invading the space it occupies.

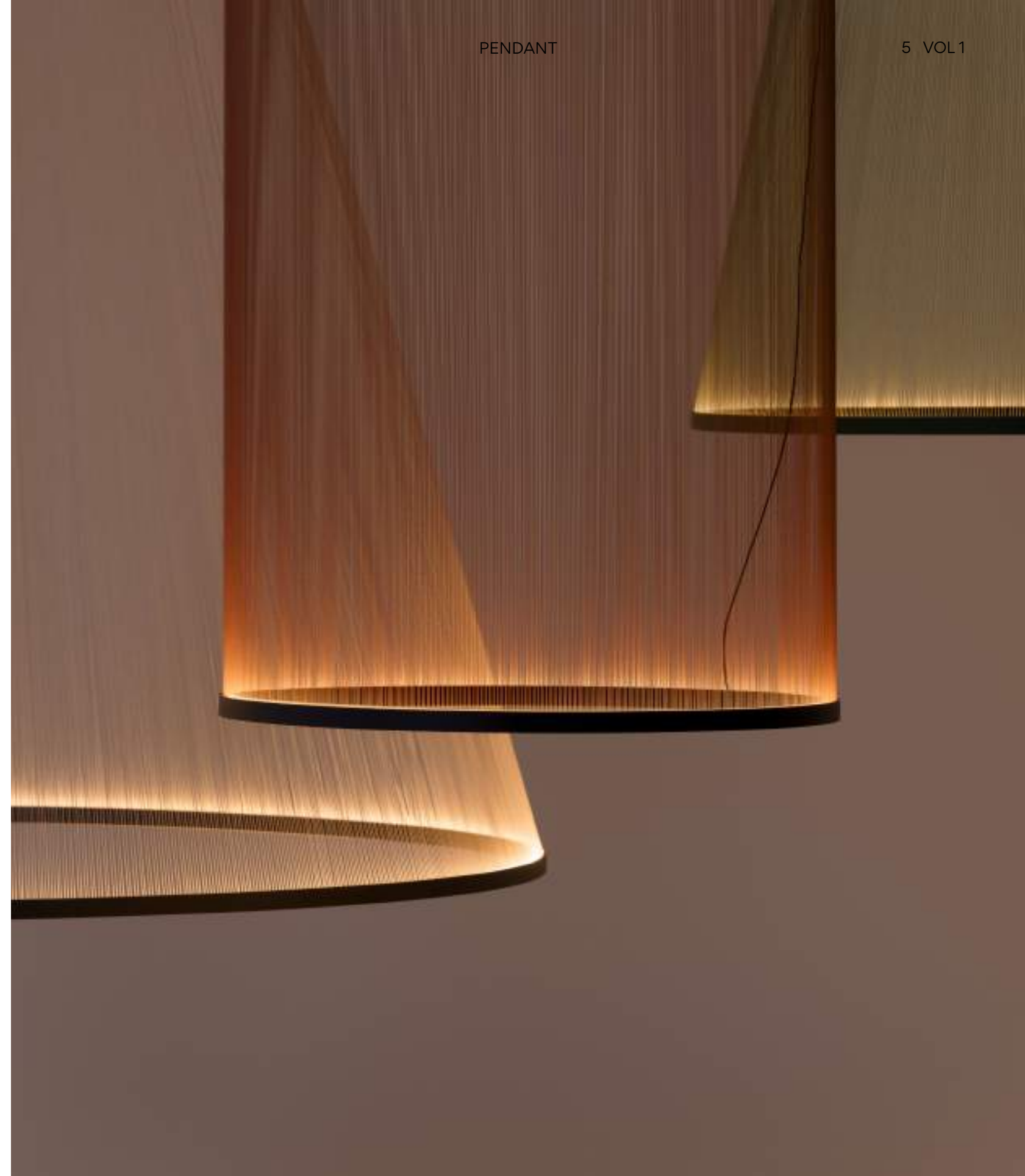









Height 70 cm



**1800**

Ø 37 cm

**1815**

Ø 54,5 cm

Height 110 cm



**1805**

Ø 37 cm

**1820**

Ø 54,5 cm

**1830**

Ø 82,5 cm

**1840**

Ø 124 cm

Height 190 cm

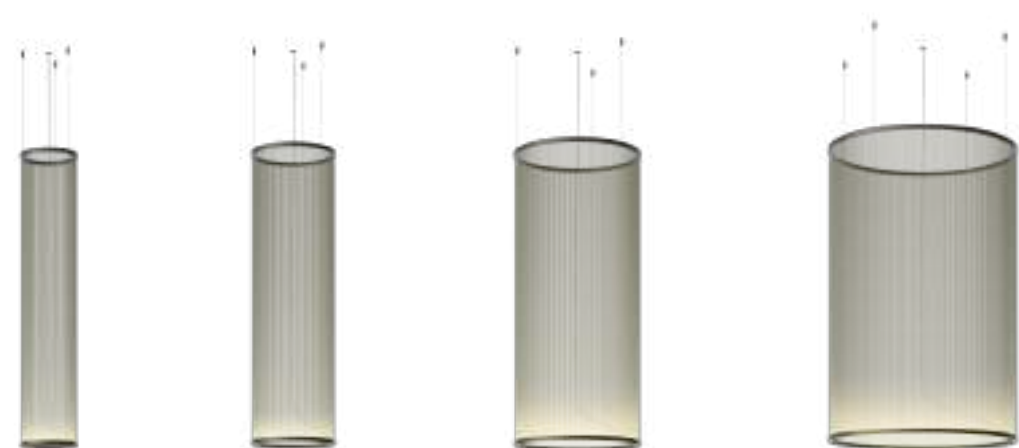

**1810**

Ø 37 cm

**1825**

Ø 54,5 cm

**1835**

Ø 82,5 cm

**1845**

Ø 124 cm

Height 70 cm



**1850**

Ø 54,5 cm

Height 110 cm



**1855**

Ø 54,5 cm

**1865**

Ø 82,5 cm

**1875**

Ø 124 cm

Height 190 cm



**1860**

Ø 54,5 cm

**1870**

Ø 82,5 cm

**1880**

Ø 124 cm

Threads.

- 24 Beige M1 (NCS S 2005-Y50R)
- 37 Terra Red (NCS S 4040-Y70R)
- 47 Green L1 (NCS S 4005-G80Y)

Rings.

- 11 Black (S 8500-N)

Textile threads: Polyester FR  
(Flame retardant)  
Upper ring: Aluminum  
Bottom ring: Brass

LED Colour Temperature

2700 K  
CRI>90

Control

Analog: Push; 1-10V  
Digital: DALI-2  
Smart: Casambi

Electrical connection options



Remote

Built-in

Surface

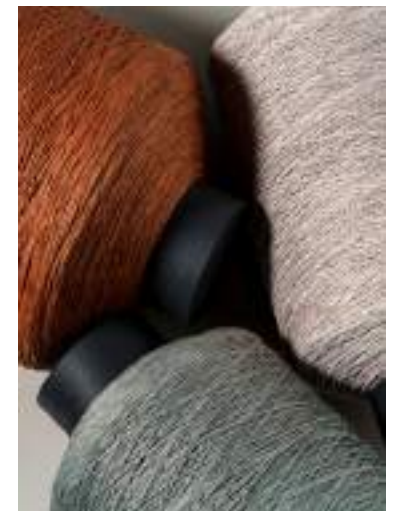

# Lily



Design by Ludovica+Roberto Palomba.

The simplicity of Lily's refined silhouette makes this fixture ideal for an elegant interior with a relaxed ambience. Suspended from a high ceiling or positioned strategically about the room, its graceful glass diffuser radiates a sense of warmth and wellbeing.







5730  
Ø 49 cm

- 11 Black (NCS S 8500-N)
- 25 Beige D1 (NCS S 4005-Y50R)

Shade: Triple opal blown glass  
Body: Aluminum



**LED Colour Temperature**  
2700 K  
CRI>90

**Control**  
Analog: 1-10V; Push  
Digital: DALI-2  
Smart: Casambi



**Electrical connection options**



Remote    Built-in    Surface



# Dama



Design by Ludovica+Roberto Palomba.

Dama is a homage to the classic lamp, ideal for shaping an intimate atmosphere with an elevated aesthetic. Combining technical quality with a layer of warmth and intimacy, the collection connects the charm of tradition with the finesse of contemporary lighting design.







Cutting-edge invisible technology allows Dama's circular light source to radiate with a gentle, uniform glow from within. Suspended from a micro-thin cable that's almost invisible to the eye, the pendant exhibits an ethereal quality, its graceful silhouette looming overhead.

- 11 Black (S 8500-N)
- 25 Beige D1 (NCS S 4005-Y50R)

Shade: Paper  
Body: Aluminum

**LED Colour Temperature**  
2700 K  
CRI>90

**Control**  
Analog: Push; 1-10V  
Digital: DALI-2  
Smart: Casambi

**Electrical connection options**



Remote    Built-in

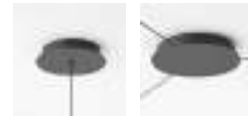

Surface    Free Wire



**3235**  
Ø 45 cm

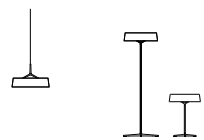

Pg 20 VOL1    Pg 364 VOL1



# Knit



Design by Meike Harde.

Light, materiality and tangibility collide with the Knit collection. Its texture is magnetic, calling out for us to touch its surface, to feel its warmth and to keep it close. Light seeps outwards through the fabric transmitting a soft 360° glow.







While the urchin, a symbol of fertility, conceals a soft inside beneath its protective outer shell, Knit delights in the femininity and softness of its outer layer. It exudes intimacy, comfort and familiarity.

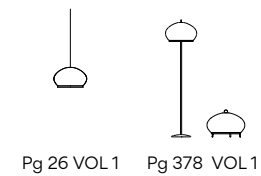
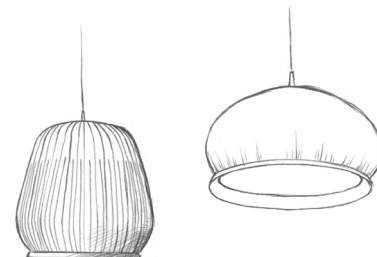

**7450**  
Ø 45 cm



**7455**  
Ø 45 cm



**7460**  
Ø 45 cm



**7470**  
Ø 65 cm



**7475**  
Ø 65 cm

● 24 Beige M1 (NCS S 2005-Y50R)

Fabric shade: PES FR  
Shade: PE- Polyethylene  
Diffuser: PMMA  
Diffuser ring: ABS

**LED Colour Temperature**  
2700 K  
CRI>90

**Control**  
Analog: 1-10V  
Digital: DALI-2  
Smart: Casambi

**Electrical connection options**

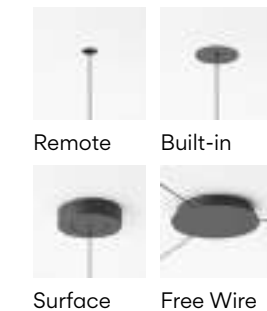

Remote

Built-in

Surface

Free Wire

# Circus

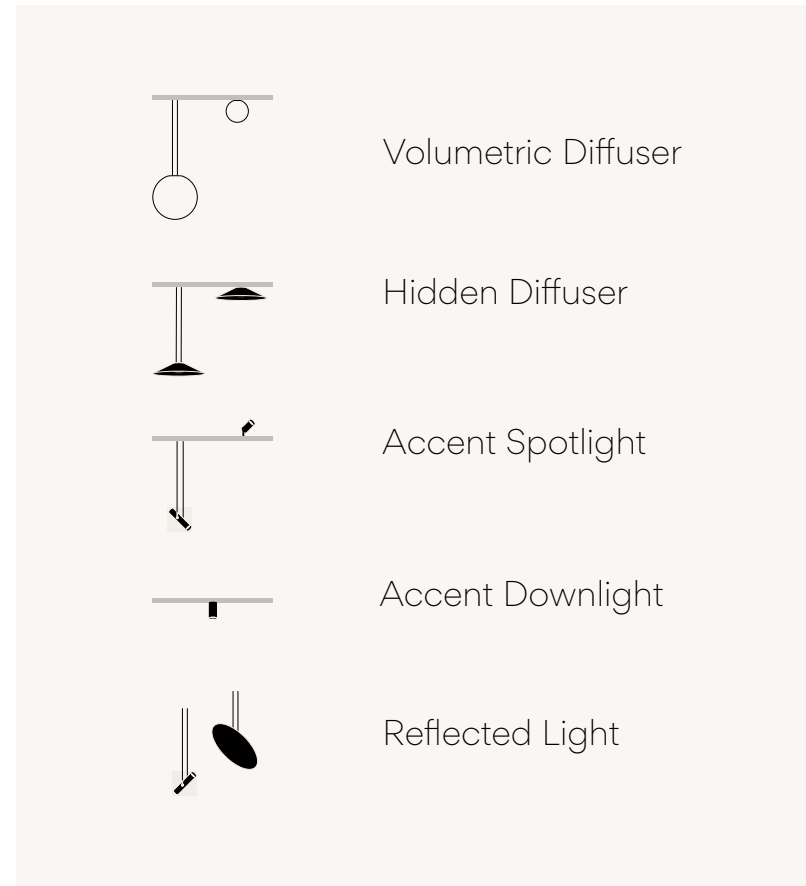

Design by Antoni Arola.

Circus is defined by its minimalist structure and signature conductive bar, delicately balanced by opposing elements to create a festival of light. A creative toolkit full of possibilities to explore and enjoy that offers total freedom of composition, multiple components and a myriad of diffuse and accented lighting effects.





Its structure is developed both vertically and horizontally and combines volumetric diffusion effects, hidden diffusers, spot and indirect lighting. This system turns the professional into a composer of atmospheres, where object luminaires can be combined with functional elements.



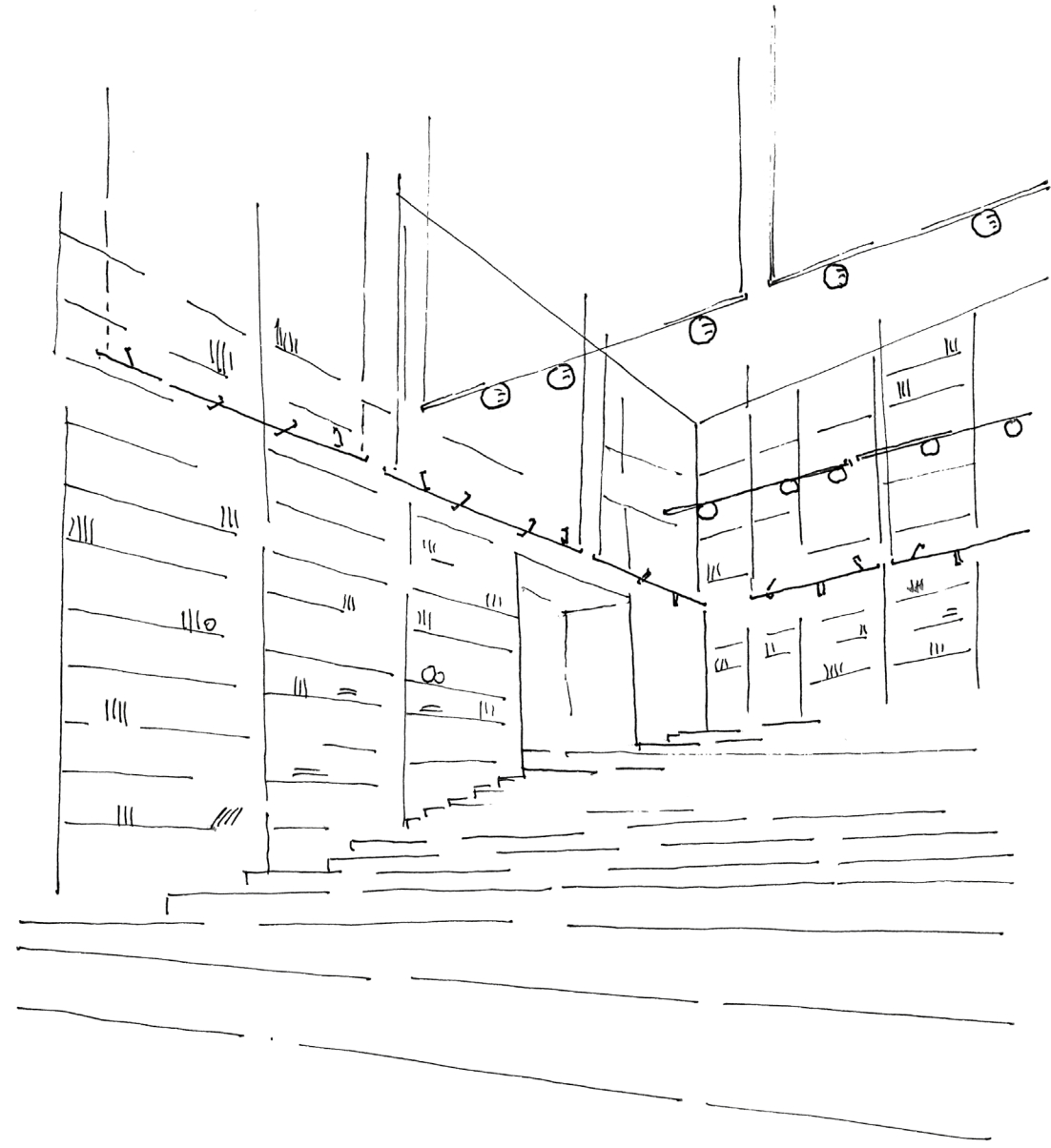



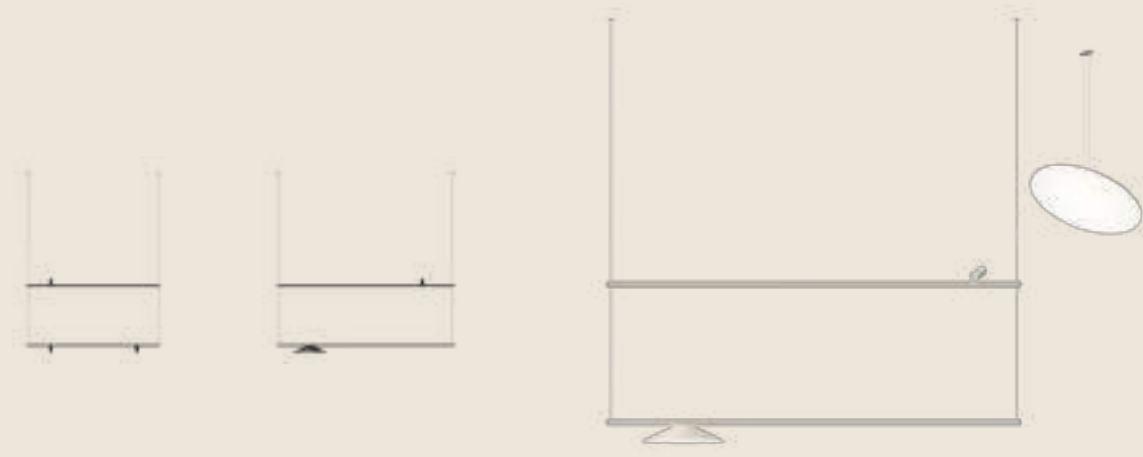



Suspended from the ceiling and positioned at any angle, the discs reflect rather than emit light. Lustrous and ethereal, these halos cast spherical shadows evocative of a circus performance or lunar eclipse when positioned above a spot.

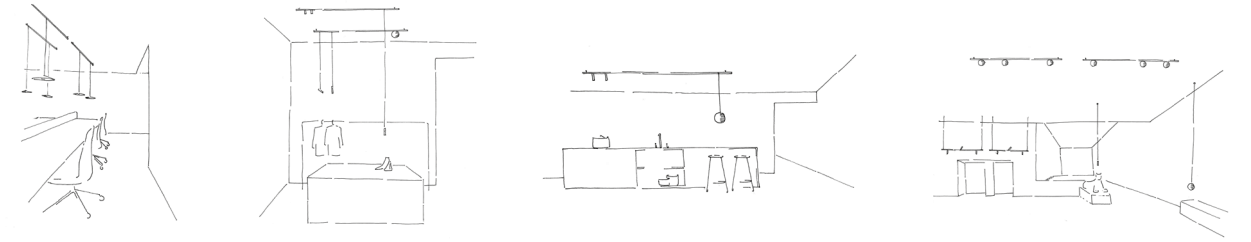



Suspended in parallel to form an equilibrium or poised in asymmetrical harmony, the slender and distinctive bar amplifies the possibilities for shaping a space. Whether composed independently, as a pair or fixed to the ceiling, it conducts electricity and transports light to different points of interest, creating a visual hierarchy within the space and between the surrounding objects.







Circus offers a variety of fixtures that can be built into the conductive bar, suspended from a track or hung directly from the surface of the ceiling. The bar amplifies the possibilities for shaping a space by conducting electricity and transporting light to wherever it is needed.

- 11 Black (NCS S 8500-N)
- 24 Beige M1 (NCS S 2005-Y50R)

Electrical connection options

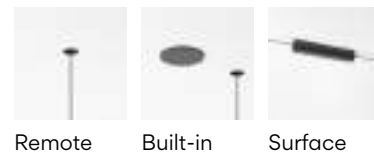

Pendant Tracks

A358 (H 3m)  
A359 (H 9m)

110 cm



A364 (H 3m)  
A365 (H 9m)

150 cm



A370 (H 3m)  
A371 (H 9m)

200 cm



A376 (H 3m)  
A377 (H 9m)

110 cm



A382 (H 3m)  
A383 (H 9m)

150 cm



A388 (H 3m)  
A389 (H 9m)

200 cm

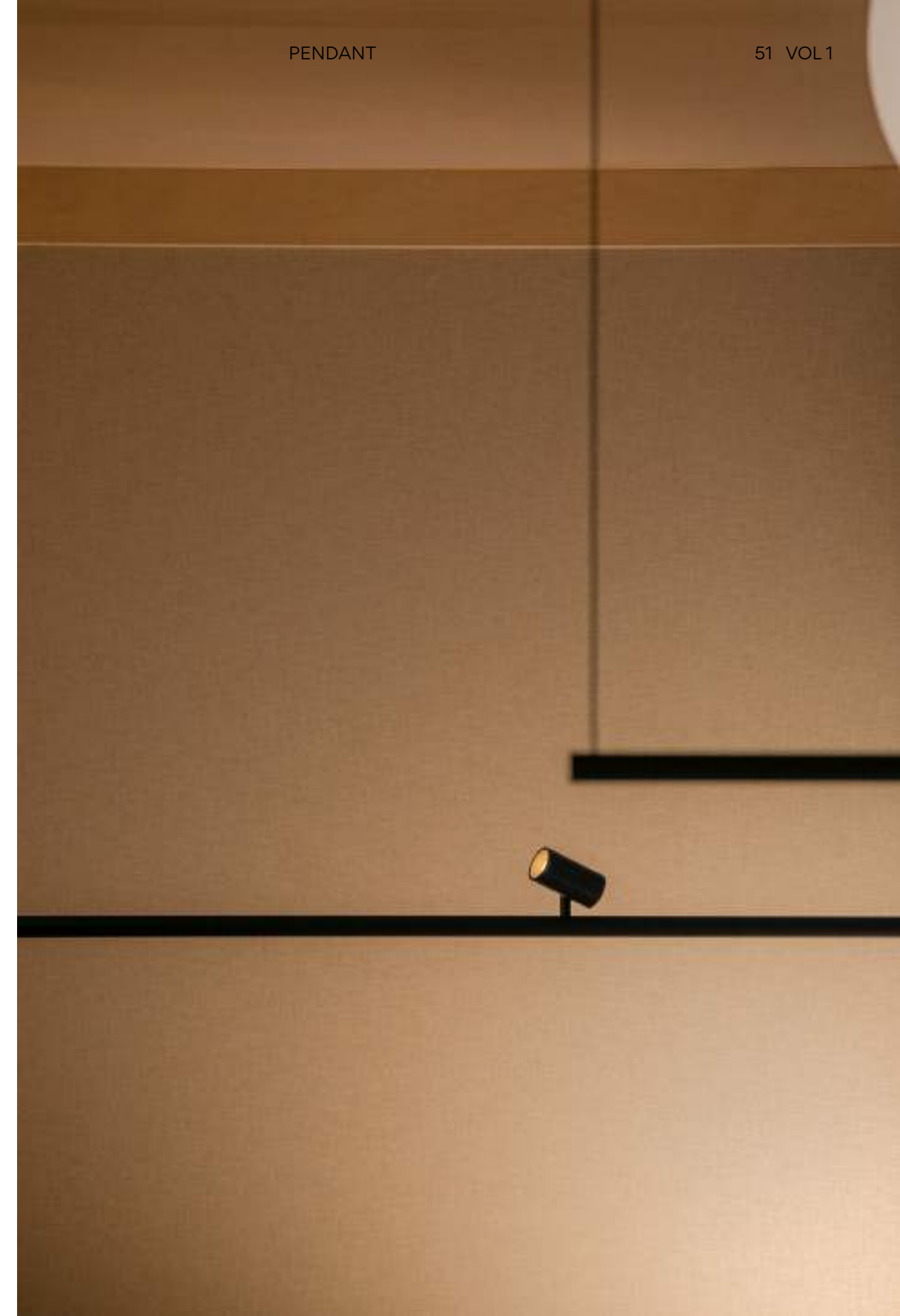

With a choice of black (11) or beige (24) finishings and dimming control, Circus offers a variety of fixtures that can be built into the conductive bar, suspended from a track or hung directly from the surface of the ceiling. With a traditional light rail the connection is visible from below, but with Circus, the luminaires can be connected to the bar from above, sealed with a cover and with pendants passing seamlessly through the lower section. This innovation has a significant impact on the aesthetic purity of the design.

- 11 Black (NCS S 8500-N)
- 24 Beige M1 (NCS S 2005-Y50R)

**Volumetric Diffuser**

Diffuser: PE- Polyethylene

**Hidden Diffuser**

Shade: Aluminum

Diffuser: PC- Polycarbonate

**Spots / Downlight**

Body: Aluminum

Lens: PMMA

**Pendant Spot**

Body: Zinc Alloy

Lens: PMMA

**LED Colour Temperature**

Volumetric Diffuser / Hidden Diffuser

Static White

2700 K; 3000 K; 3500 K

Tunable White (1800 K- 4000 K)

Tunable Red (Red - 2700 K)

**Spots / Downlight**

Static White

2700 K - 680 lm

3000 K - 711 lm

3500 K - 737 lm

7,2W

Only ref. 0131, 0132,

0141, 0142, 0152 and 0153

Tunable White (1800 K - 4000 K)

Smart (P2P)

308 lm - 504 lm 5,5W

Only ref. 0131, 0141 and 0152

Tunable Red (Red - 2700 K)

Smart (P2P)

155 lm - 581 lm 7W

CRI>90

**Control**

Digital: DALI-2 (P2P)

Smart: Casambi (simultaneous line);

Casambi (P2P); ProtoPixel\* (P2P)

\*ProtoPixel products are compatible with all other DALI-2 products via a designated gateway (please consult us)

Updated detailed spec sheets on [vibia.com](http://vibia.com)

Volumetric Diffuser

PENDANT

0162



Ø 20 cm

0167



Ø 45 cm

DIRECT TO TRACK

0164



Ø 20 cm

Hidden Diffuser

PENDANT

0155



Ø 40 cm

DIRECT TO TRACK

0157

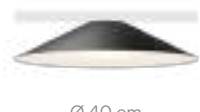

Ø 40 cm

Accent Spotlight

PENDANT

0140 Narrow  
0141 Medium  
0142 Wide



Ø 4 cm

DIRECT TO TRACK

0130 Narrow  
0131 Medium  
0132 Wide



Ø 4 cm

Accent Downlight

DOWNLIGHTS

0151 Narrow  
0152 Medium  
0153 Wide



Ø 4 cm

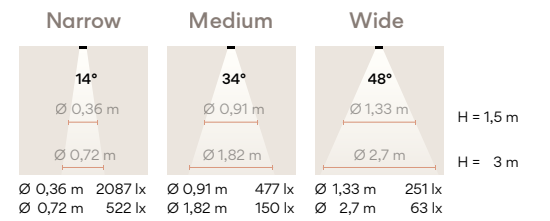



Suspended from the ceiling and positioned at any angle, a range of reflector discs reflect diffuse light from a spot angled towards them. Lustrous and ethereal, they cast a spherical shadow on the adjacent surface like a lunar eclipse.

● 11 Black  
(Bottom face: White / Top face: Black)

Reflected Light

LIGHT REFLECTOR

A146

A147

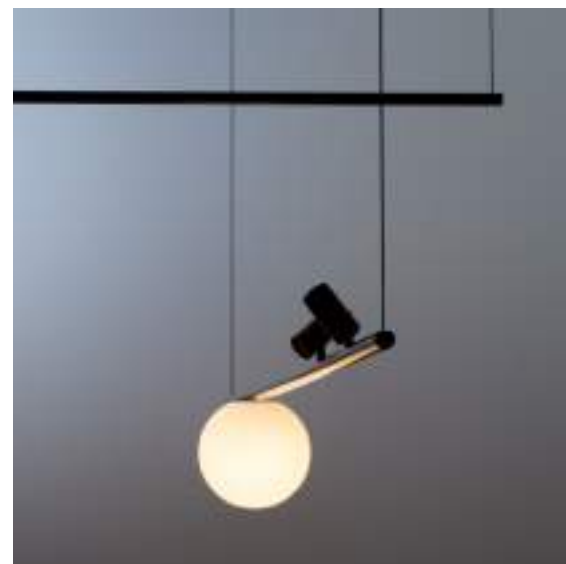
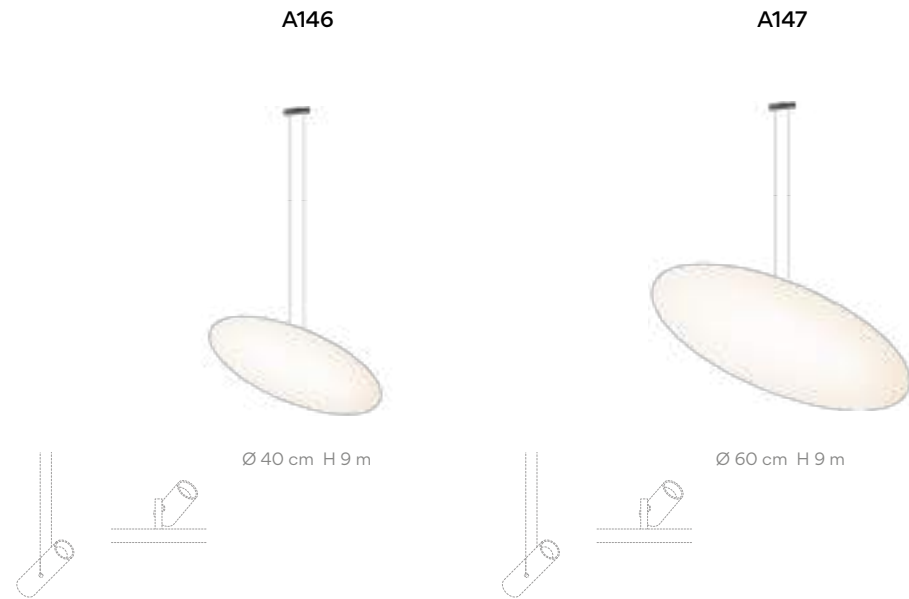

Dynamic light

Dynamic light allows professionals to play with subtle degrees of intensity and colour temperature to recreate a subtle ambience for every scene within a lighting project

A source of emotion

Static, tunable white and tunable red

Designing an atmosphere of wellbeing is based on two main axes: **space** and **time**. The axis of time implies the concept of dynamic light .

Atmosphere design is intentional, depending on the **design of different scenes according to the specific use of a space** as it evolves throughout the day. Light is dynamic because ambience also depends **on the time of day** and on the influence of the natural light at every moment.

Throughout the day our circadian rhythms respond primarily to light, which regulates our sense of physical and mental wellbeing.

Vibia's approach to coloured light invites the use of colour and intensity to create and experience different atmospheres, making them as natural and subtle as possible.

Colour is a source of emotion, it can instantly set a mood, convey a feeling or generate a sense of wellbeing.



Circus product options offer a range of static white in three different temperatures as well as the option of tunable white. Tunable lighting allows for comprehensive temperature regulation: colour temperature can be precisely tuned depending on the desired atmosphere for every scene.

The **tunable red** option allows you to glide from red to white, exploring a range of relaxing and cosy effects. Tunable white lighting option allows for comprehensive temperature regulation depending on the atmosphere of every scene.

Static White

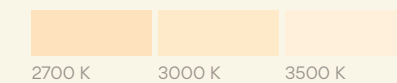

Tunable White

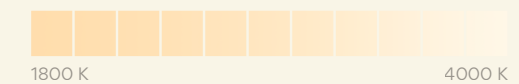

Tunable Red



Contact Vibia Support Service at [vibia.com](http://vibia.com) for any kind of assistance or recommendation when designing an atmosphere of wellbeing, or if you require support with control system approach.

# Circus Solo

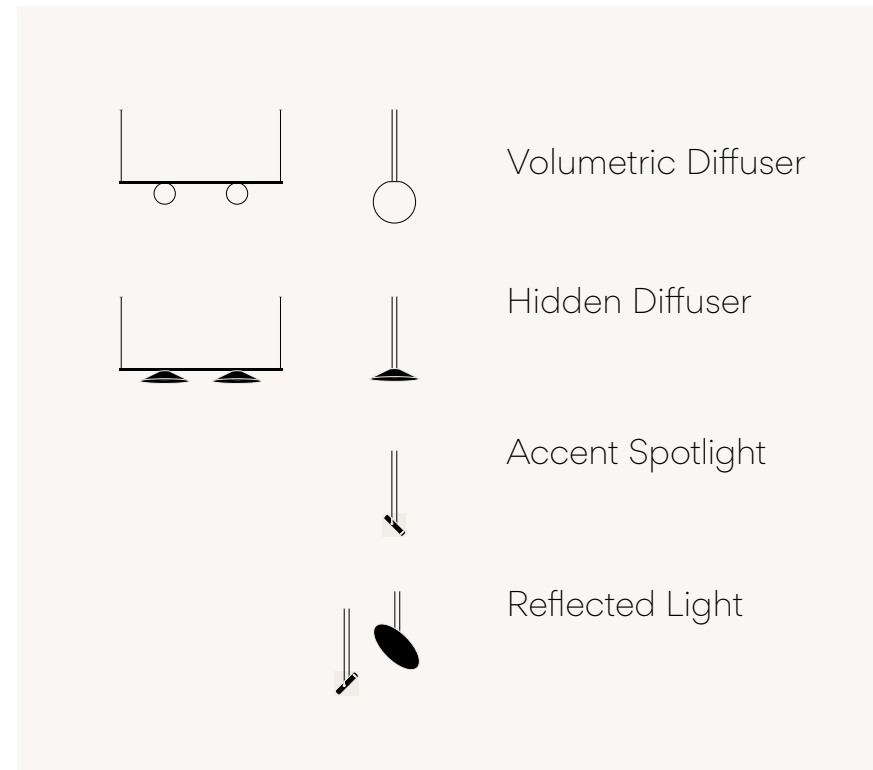

Design by Antoni Arola.

The Circus system incorporates a range of independent elements that can be surface mounted to the ceiling, including spots, downlights and general lighting fixtures. This line allows professionals to create harmonic compositions and subtle atmospheres that break with the standards.



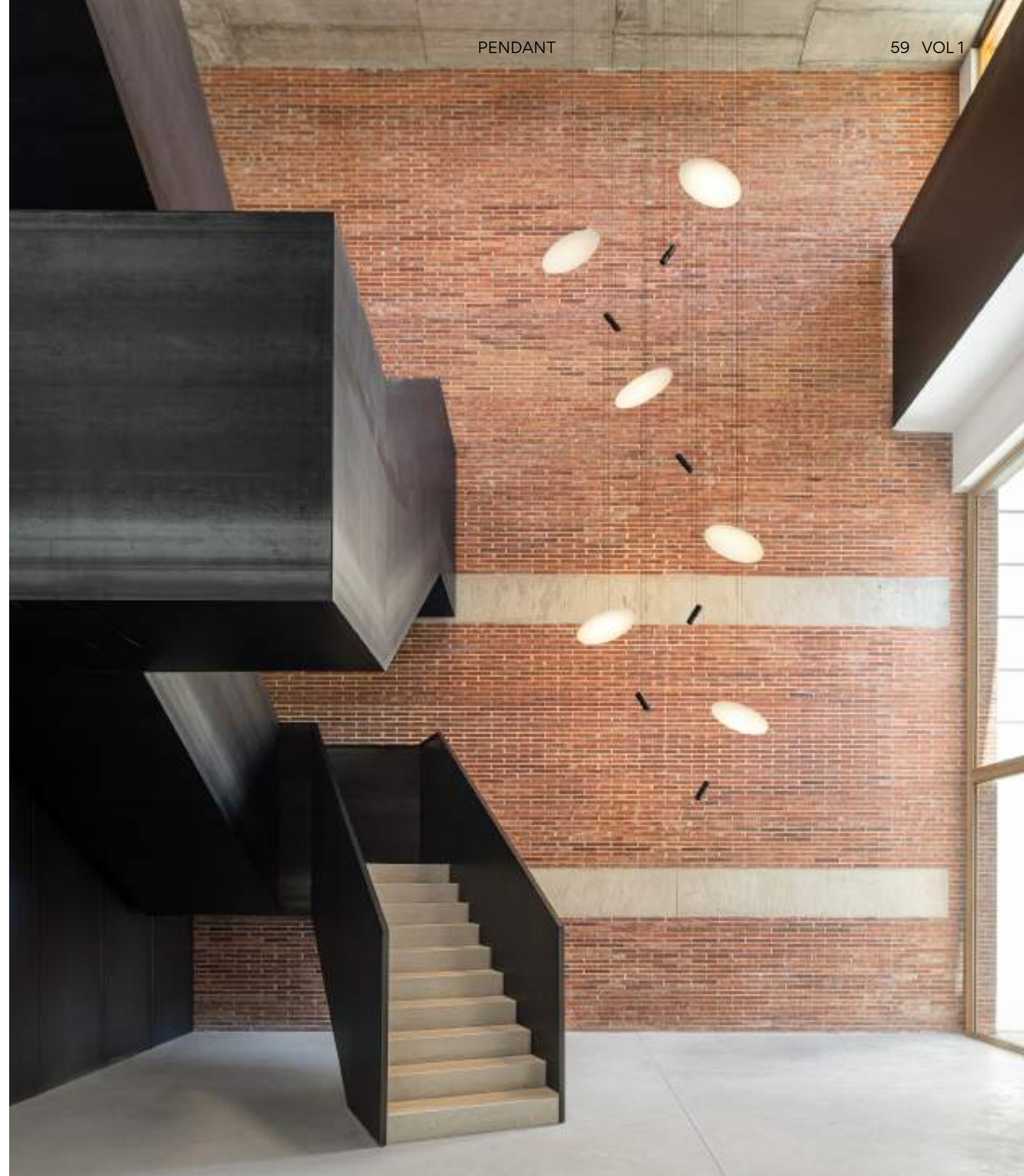



- 11 Black (NCS S 8500-N)
- 24 Beige M1 (NCS S 2005-Y50R)

**Volumetric Diffuser**

Diffuser: PE- Polyethylene  
Top cover: Aluminum

**Hidden Diffuser**

Shade: Aluminum  
Diffuser: PC- Polycarbonate  
Top cover: Aluminum

**Spots**

Body: Zinc Alloy  
Lens: PMMA

**LED Colour Temperature**

Volumetric Diffuser / Hidden Diffuser

Static White  
2700 K; 3000 K; 3500 K  
Tunable White (1800 K- 4000 K)  
Tunable Red (Red - 2700 K)

**Pendant Spot**

Static White  
2700 K - 680 lm  
3000 K - 711 lm  
3500 K - 737 lm  
7,2W

Only ref. 0177 and 0178  
Tunable White (1800 K - 4000 K)  
Smart  
308 lm - 504 lm 5,5W

Only ref. 0177  
Tunable Red (Red - 2700 K)  
Smart  
155 lm - 581 lm 7W

CRI>90

**Control**

Analog: Push  
Digital: DALI-2\*  
Smart: Casambi;

\*DALI-2 products are compatible (via a designated gateway) with all ProtoPixel dynamic-light solution products.

**Electrical connection options**



Remote Built-in Surface

Accent Spotlight

Surface Built-In

- 0176 Narrow
- 0177 Medium
- 0178 Wide



Ø 4 cm

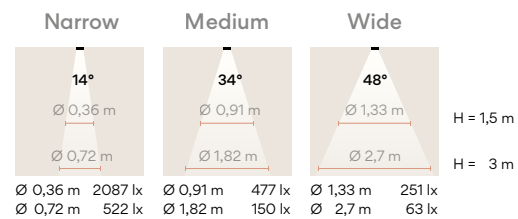

Pg 56 VOL 1 Pg 62 VOL 2

Volumetric Diffuser

Surface Built-In

0185

0187



Ø 20 cm



Ø 45 cm

Hidden Diffuser

Surface Built-In

0182



Ø 40 cm

Surface Built-In Remote

0193

150 x max. 200 cm



Ø 20 cm

Surface Built-In Remote

0196

150 x max. 200 cm



Ø 40 cm

Suspended from the ceiling and positioned at any angle, a range of reflector discs reflect diffuse light from a spot angled towards them, rather than emitting their own light. Lustrous and ethereal, they cast a spherical shadow on the adjacent surface like a lunar eclipse.

● 11 Black  
(Bottom face: White / Top face: Black)

## Reflected Light

### LIGHT REFLECTOR

**A146**

Ø 40 cm H 9 m

**A147**

Ø 60 cm H 9 m



## Dynamic light

Dynamic light allows professionals to play with subtle degrees of intensity and colour temperature to recreate a subtle ambience for every scene within a lighting project

## A source of emotion

## Static, tunable white and tunable red

Designing an atmosphere of wellbeing is based on two main axes: **space** and **time**. The axis of time implies the concept of dynamic light.

Atmosphere design is intentional, depending on the **design of different scenes according to the specific use of a space** as it evolves throughout the day. Light is dynamic because ambience also depends **on the time of day** and on the influence of the natural light at every moment.

Throughout the day our circadian rhythms respond primarily to light, which regulates our sense of physical and mental wellbeing.

Vibia's approach to coloured light invites the use of colour and intensity to create and experience different atmospheres, making them as natural and subtle as possible.

Colour is a source of emotion, it can instantly set a mood, convey a feeling or generate a sense of wellbeing.



Circus product options offer a range of static white in three different temperatures as well as the option of tunable white. Tunable lighting allows for comprehensive temperature regulation: colour temperature can be precisely tuned depending on the desired atmosphere for every scene.

The **tunable red** option allows you to glide from red to white, exploring a range of relaxing and cosy effects. Tunable white lighting option allows for comprehensive temperature regulation depending on the atmosphere of every scene.

### Static White

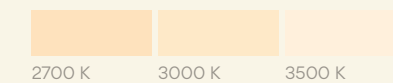

### Tunable White

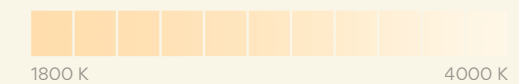

### Tunable Red



# Sticks

Design by Arik Levy.

Fusing technology, space, and architecture, Sticks offers a creative toolkit for integrating light elements into an interior environment. Graphic in form, the collection consists of minimalist Aluminum rods that transform linear light into a floating sculpture.









● 11 Black (NCS S 8500-N)

Stick: Aluminum  
Diffuser: PC- Polycarbonate

**LED Colour Temperature**  
2700 K; 3000 K; 3500 K  
CRI>90

**Control**  
Surface canopy, Built-in, Remote driver:  
1-10V.

**Electrical connection options**



Surface canopy    Built-in disc S    Remote driver Built-in Micro



Horizontal Pendants version with a UGR index <19 available.

Create your own composition easy and quick at [vibia.com](http://vibia.com) selecting the option that best fits your needs.

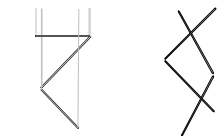

Connecting space application

Custom configurations include ceiling-to-ceiling, wall-to-wall, floor-to-wall, wall-to-ceiling, or suspended from the ceiling into open space. Through their physical form and the light they cast, they create and disrupt architectural planes.

**Connectable**

The Sticks collection has three sizes: 1.5 m , 2 m, or 3 m, and they can be connected one to each other to a total maximum length of 6.5 meters per electrical connection.

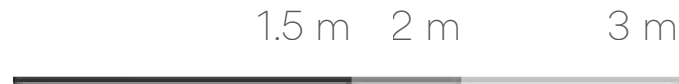

Sticks are connected one to each other with a 15 cm length cord.



Each stick rotates on its own axis, allowing light to be directed precisely where needed.

**Pendants-Wall**

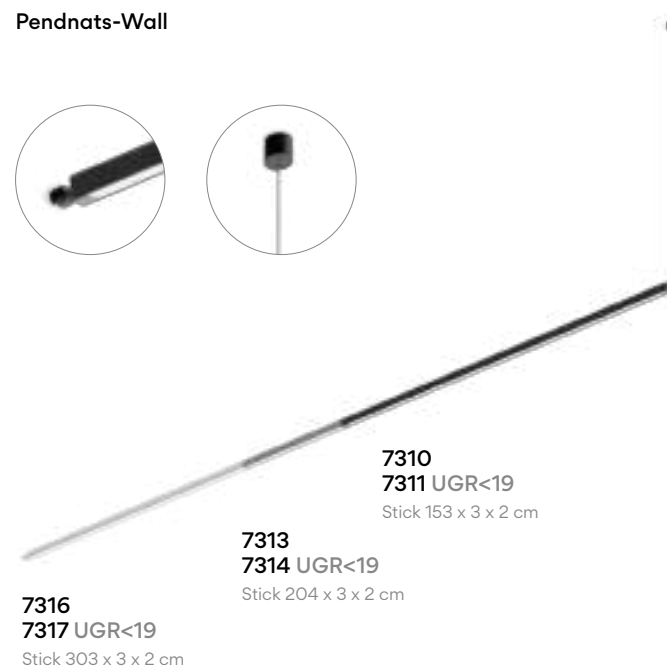
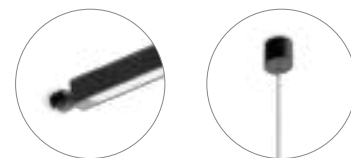

**Vertical Pendant**

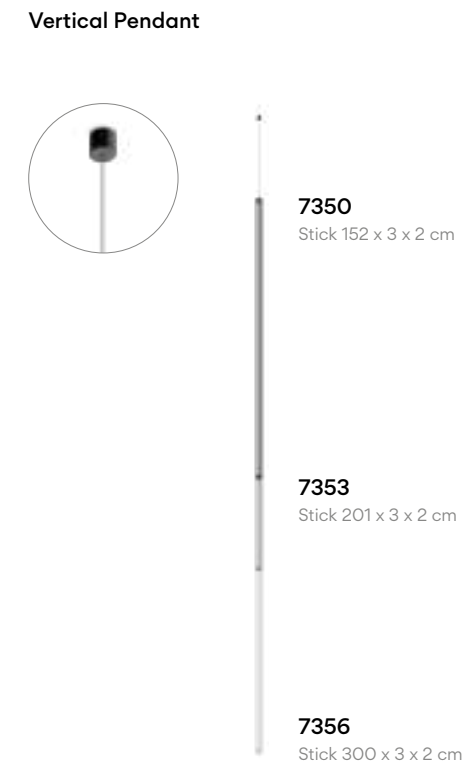

**Pendants-Pendants**

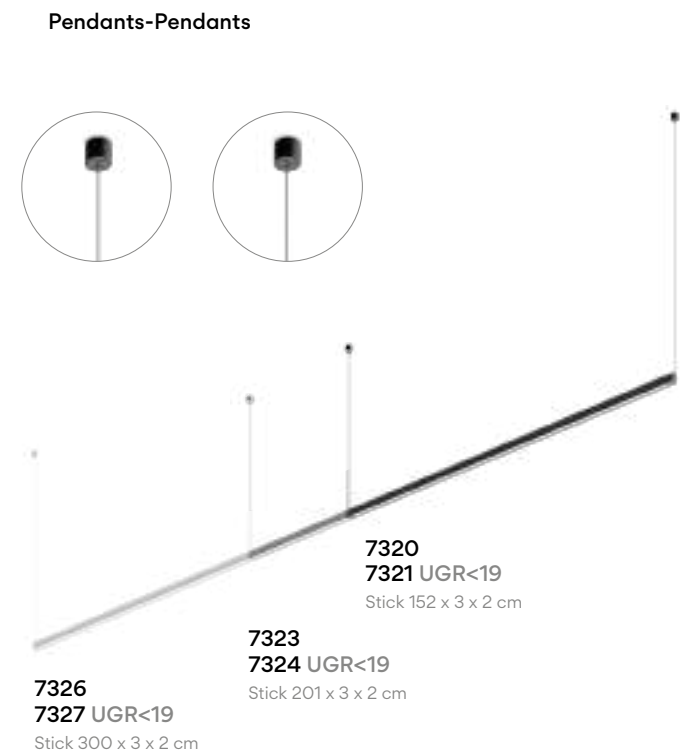
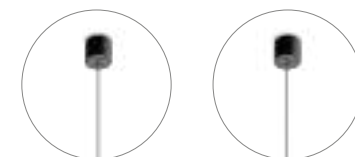

# Sticks Solo

Design by Arik Levy.

A pure solution for a minimalist interior, Sticks Solo features a range of horizontal pendants of various lengths and incorporates a range of electrical connection options for seamless integration with the surrounding architecture.



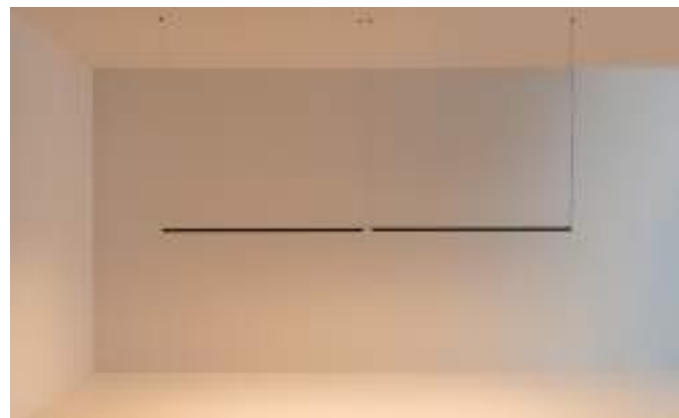

The stick rotates on its own axis, allowing light to be directed precisely where needed

● 11 Black (NCS S 8500-N)

Stick: Aluminum  
Diffuser: PC- Polycarbonate

**LED Colour Temperature**

2700 K; 3000 K; 3500 K  
CRI>90

**Control**

Analog: 1-10V  
Digital: DALI-2  
Smart: Casambi

**Electrical connection options**

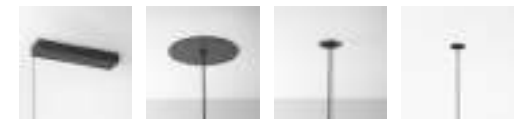

Surface canopy   Built-in disc S   Remote Micro   Remote XXS

**7360**  
**7361** UGR<19  
152 x 2 x 3 cm



**7363**  
**7364** UGR<19  
201 x 2 x 3 cm



**7365**  
**7366** UGR<19  
307 x 2 x 3 cm



**7368**  
**7369** UGR<19  
405 x 2 x 3 cm

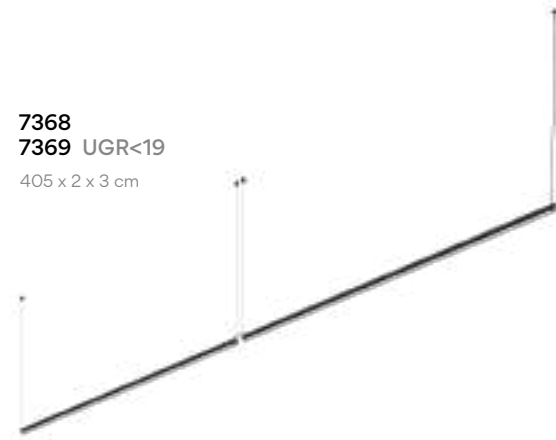

Linear flat  
diffuser



Horizontal Pendants  
version with a UGR  
index <19 available.

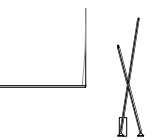

# Kontorno

Design by Sebastian Herkner.

Consisting of an elegant linear framework complemented by a cylindrical diffuser or curved reflector, the Kontorno collection envelops the light source it contains, offering diffuse, balanced illumination.





The Kontorno pendant consists of a streamlined silhouette that appears to float from invisible cables. Embedded with LEDs, curved volumes are balanced by sleek geometric architecture. The reflector lends an intentional look of raining light.

● 11 Black (NCS S 8500-N)

Concave shade: Aluminum  
 Diffuser: PC- Polycarbonate  
 Pendant structure: Steel  
 Canopy: Aluminum

**LED Colour Temperature**

2200 K; 2700 K; 3000 K; 3500 K  
 CRI>90

**Control**

Analog: Push; 1-10V  
 Digital: DALI-2  
 Smart: Casambi

Aluminum Shade



**6434**  
92 cm



**6436**  
122 cm



**6438**  
162 cm

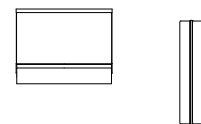

Pg 80 VOL1 Pg 278 VOL2







The Kontorno pendant consists of a streamlined silhouette that appears to float from invisible cables. Embedded with LEDs, curved volumes are balanced by sleek geometric architecture. The cylindrical diffuser evenly illuminates the surrounding space.

● 11 Black (NCS S 8500-N)

Glass shade: Opal triplex  
Diffuser: PC- Polycarbonate  
Pendant structure: Steel  
Canopy: Aluminum

**LED Colour Temperature**  
2200K; 2700 K; 3000K  
CRI>90

**Control**  
Analog: Push; 1-10V  
Digital: DALI-2  
Smart: Casambi

Glass Shade



**6474**  
92 cm



**6476**  
122 cm

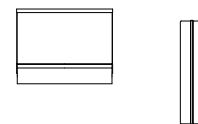

Pg 80 VOL1 Pg 278 VOL2



# Ghost

Design by Arik Levy.

A study in contrasts, the Ghost collection embodies both spirit and materiality, discretion and presence. A contemporary reimagining of the grand lights that once graced entryways and living areas, its sensuous form radiates with a warm, welcoming glow.





4987

Ø 47,5 cm

True to its namesake, the Ghost pendant possesses an ethereal presence. Large in scale yet elegant in sensibility, the luminaire floats overhead from nearly invisible cables to provide a striking focal point in any space. Crafted meticulously of mouth-blown opal triplex glass, Ghost's rich, smooth material generates a warm, ambient glow.

● 11 Black (NCS S 8500-N)

Diffuser: Opal Glass  
Metal parts: Aluminum

**LED Colour Temperature**

2700 K  
CRI>90

**Control**

Analog: Push; 1-10V  
Digital: DALI-2  
Smart: Casambi

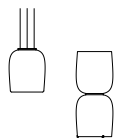

Pg 90/438 VOL1



# Flat

Design by Ichiro Iwasaki.

A study in geometry, the Flat collection features distinctive, disc-shaped diffusers that form horizontal planes of light, infusing a space with pools of soft illumination.





INDIVIDUAL MODEL



5930  
Ø 90 cm



5935  
Ø 40 cm



5940  
Ø 55 cm

- 13 Off-White (NCS S 1000-N)
- 37 Terra Red (NCS S 4040-Y70R)
- 47 Green L1 (NCS S 4005-G80Y)

Shade: Aliminum  
 Diffuser: PC- Polycarbonate  
 Pendant structure: Steel  
 Canopy: Aluminum

**LED Colour Temperature**  
 2700 K; 3500 K  
 CRI>90

**Control**  
 Analog: Push; 1-10V  
 Digital: DALI-2  
 Smart: Casambi

**Ref. 5935 and 5940.**  
**Electrical connection options**



Remote Built-in Surface Free Wire

Upper side of the disc available in:  
 Off-White, Terra Red y Green L1.

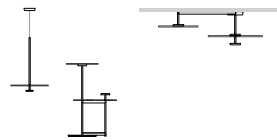

MULTIPLE MODELS

Set your composition to [vibia.com](http://vibia.com)

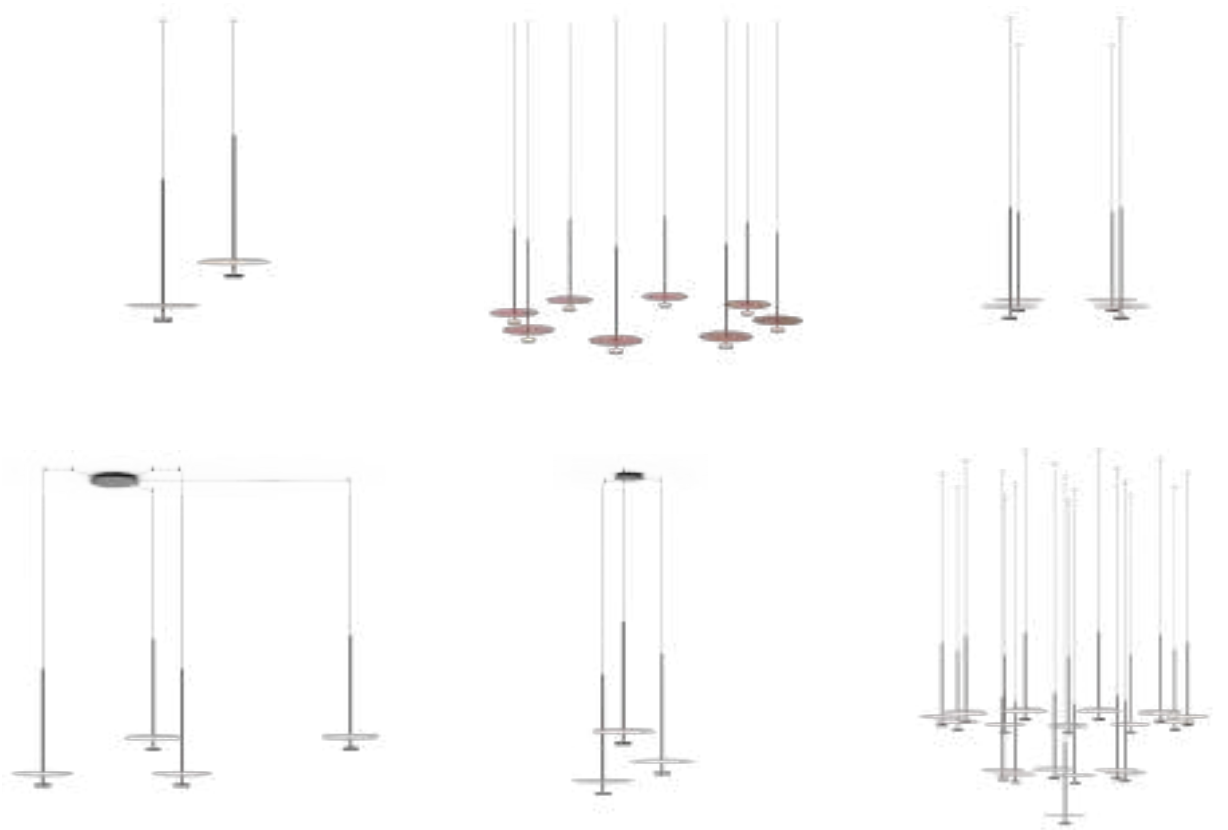

# Tube Free



Design by Ichiro Iwasaki.

Tube Free seemingly emancipates the tube from its point of connection to create a landscape of independent pendants. When set out over a space, the arrangement of numerous tubes of equal or varying heights creates a delicate structure and facilitates a harmonious congregation of shades.





Composed of two different sized luminaires and a black tube that extends vertically, it conducts light to wherever it is required, integrating within the architecture of any interior.



INDIVIDUAL MODEL



**6160**  
Ø 22 cm



**6165**  
Ø 28,5 cm

- 10 White (NCS S 0300-N)
- 15 Grey L2 (NCS S 2500-N)
- 16 Grey M1 (NCS S 4500-N)
- 21 Black Grey (NCS S 7000-N)
- 24 Beige M1 (NCS S 2005-Y50R)
- 37 Terra Red (S 4040-Y70R)

Finish customization  
(Available options: Vibia colour palette)

Diffuser: PC- Polycarbonate  
Shade: Aluminum  
Led support: Aluminum  
Tube: Steel  
Canopy: Steel

**LED Colour Temperature**  
2700 K; 3000 K; 3500 K  
CRI>90

**Control**  
Analog: 1-10V; Push  
Digital: DALI-2  
Smart: Casambi

**Electrical connection options**

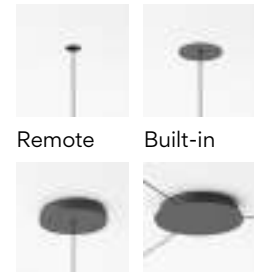

Remote Built-in

Surface Free Wire

**BIND related product**



MULTIPLE MODELS

Set your composition to [vibia.com](http://vibia.com)



# Tube



Design by Ichiro Iwasaki.

Tube is a modular pendant and ceiling system with numerous possibilities. Composed of three different sized luminaires and a black tube that extends both vertically and horizontally, it conducts light to wherever it is required, integrating within the architecture of any interior.

Tube is an innovative system of hanging lamps: a network of tubes directs the light from a single point of connection to numerous luminaires that can be freely positioned within a space. The tubes draw distinct lines across a wall, ceiling or through space, offering a graphic tool with which to design a space, as well as the opportunity to configure multiple configurations.

- 10 White (NCS S 0300-N)
- 15 Grey L2 (NCS S 2500-N)
- 16 Grey M1 (NCS S 4500-N)
- 21 Black Grey (NCS S 7000-N)
- 24 Beige M1 (NCS S 2005-Y50R)
- 37 Terra Red (S 4040-Y70R)

**LED Colour Temperature**  
2700 K; 3000 K; 3500 K  
CRI>90

**Control**  
Analog: Push; 1-10V  
Digital: DALI-2  
Smart: Casambi

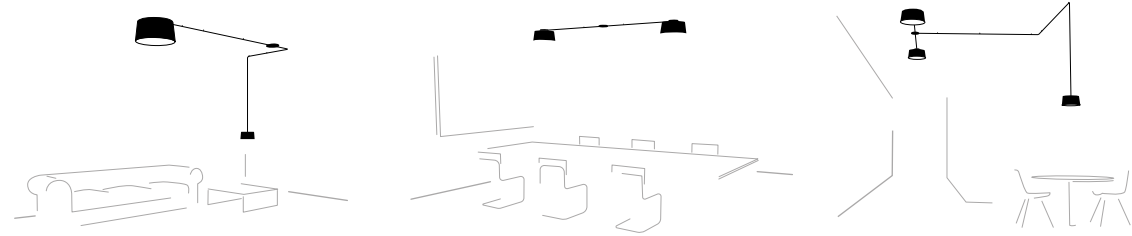

Set your composition to [vibia.com](http://vibia.com)



# Guise



Design by Diez Office.

Crafted of precision-cut glass and embedded with a row of recessed LEDs, Guise explores the relationship between light and transparency. The light inside the glass appears invisible, while the delicately engraved surface generates a beautiful diffusion.





Crafted of borosilicate glass, a lightweight and industrial-grade material prized for its superior strength and durability, the Guise pendant can be fitted horizontally or vertically in any space. It is suspended from an invisible cable which lends a sense of weightlessness to the overall expression. Radiating with an intense glow, a special sensor offers dimming control without direct contact.

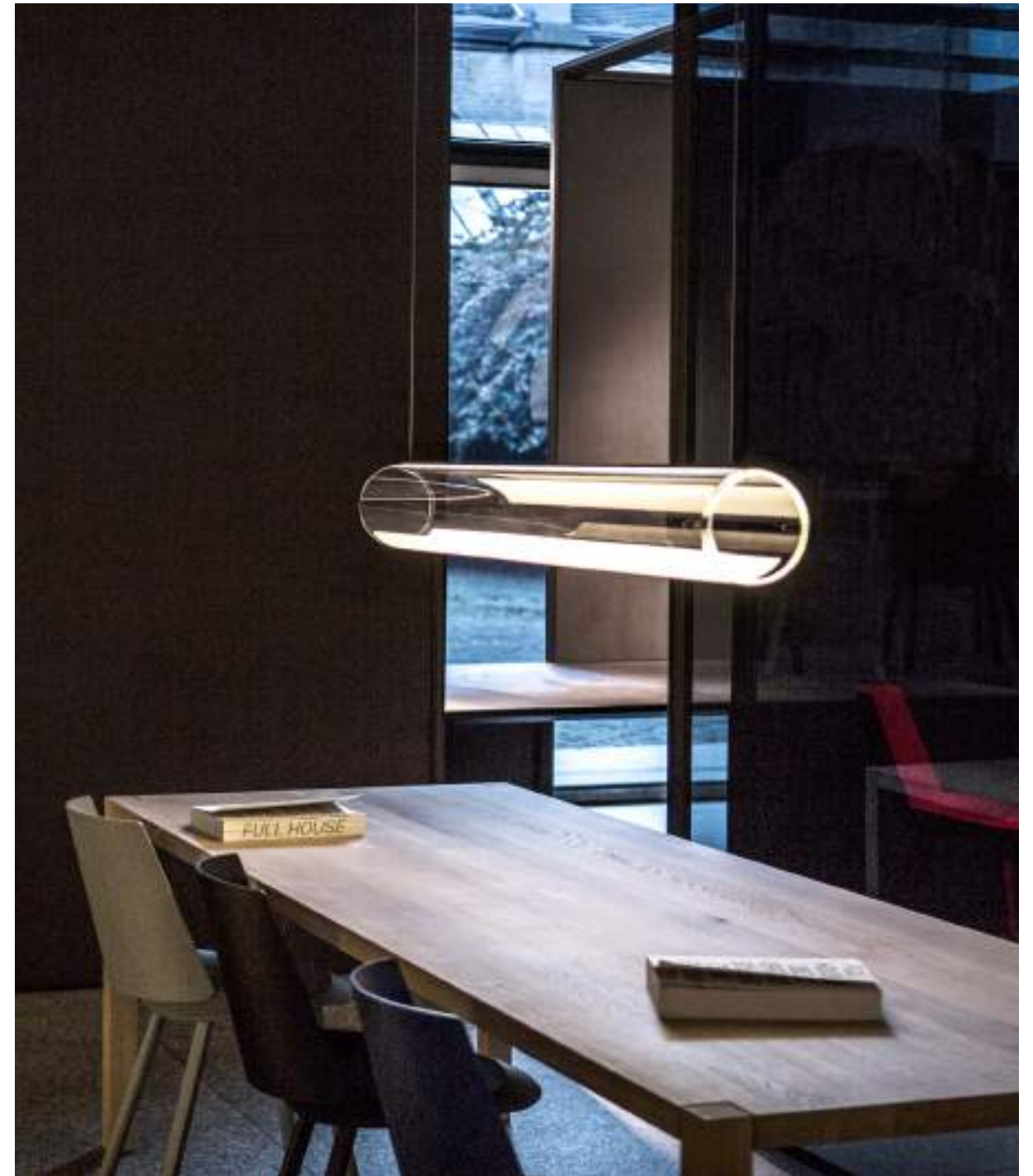

● 18 Graphite (ADAPTA RF9913WX)

Diffuser: Borosilicate glass  
Body: Aluminum  
LED support: Aluminum  
Canopy: Steel

**LED Colour Temperature**

3000 K  
CRI>90

**Control**

Analog: Push;  
Sensor; 1-10V  
Digital: DALI-2  
Smart: Casambi

**2282**  
Ø 25 cm



**2288**  
Ø 40 cm

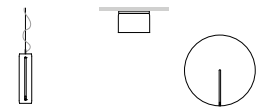

Pg 110 VOL 1 Pg 168/288 VOL 2

**2277**  
89 cm



**2270**  
Ø 16 cm



**2272**  
Ø 16 cm



2272 Dimmer: optical sensor

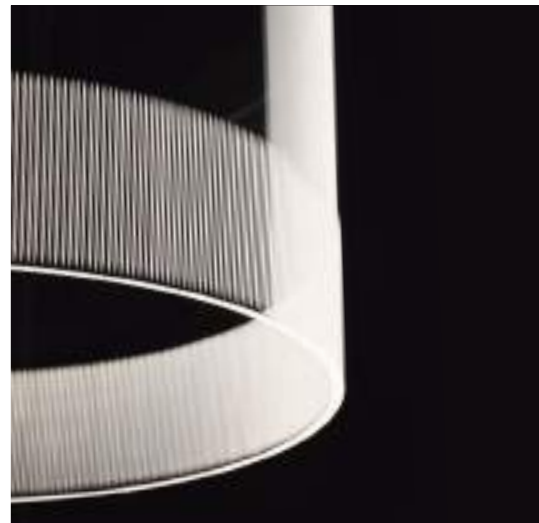

# Skán



Design by Lievore, Altherr, Molina.

Skán is a sleek and unadorned fixture. It combines lean lines with soothing purity of form, adding a minimalist sensibility to any space.





Sleek and understated, the Skan pendant adds a minimalist sensibility to any space. The LED-powered design is marked by a restrained geometric profile with its elegant interplay of lean lines and gentle curves. Suspended overhead by a lean cable, its saucer-like silhouette is at once delicate and dramatic.



INDIVIDUAL MODEL

Skan's sleek disc design is defined by its pure form and simple lines. The LED-powered pendant features a steel canopy and diffuser that casts a broad, bright dimmable light. Streamlined and understated, it lends a quiet elegance as a single lamp or grouping of pendants.



**O270**  
Ø 30 cm

**O275**  
Ø 60 cm

- 10 White (NCS S 0300-N)
- 11 Black (NCS S 8500-N)
- 24 Beige M1 (NCS S 2500-Y50R)
- 37 Terra Red (NCS S 4040-Y70R)
- 42 Blue M1 (NCS S 5010-B10G)
- 47 Green L1 (NCS S 4005-G80Y)

Finish customization  
(Available options: Vibia colour palette)

Shade: Aluminum  
Diffuser: PMMA  
Canopy: Steel

**LED Colour Temperature**  
2700 K; CRI >90  
3000 K; CRI >80  
3500 K; CRI >90

**Control**  
Analog: Push; 0-10V; 1-10V  
Digital: DALI-2  
Smart: Casambi

**Electrical connection options**

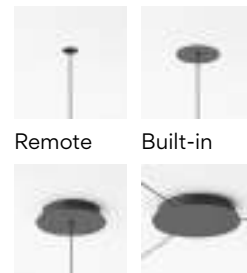

**BIND related product**



MULTIPLE MODELS

Set your composition at [vibia.com](http://vibia.com)

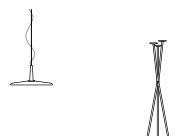
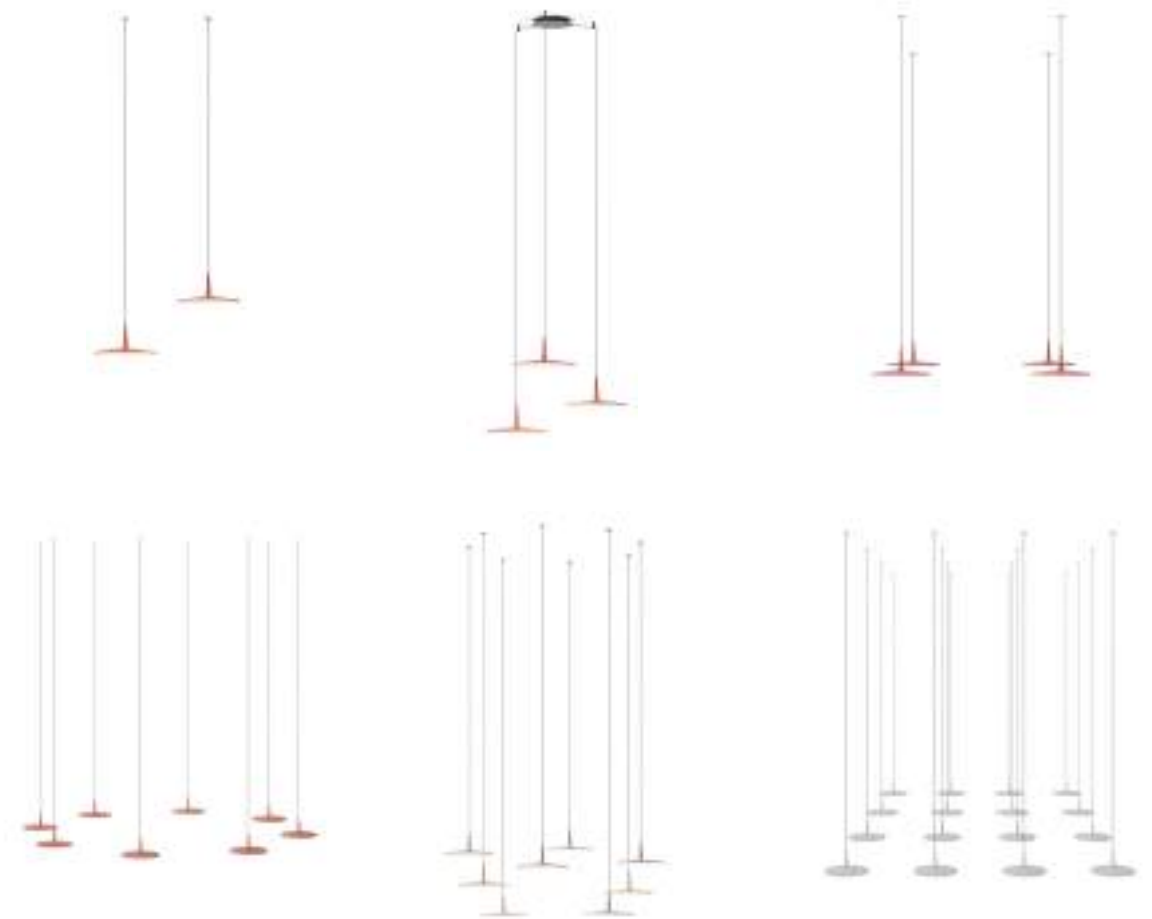

# Warm



Design by Ramos & Bassols.

A contemporary take on a timeless design, Warm features a generously sized, classic drum shade with a muted colour palette that provides a refined touch.





**4925 4926**  
 Ø 62 cm

Screen shade: Ref. 4925

- 10 White (NCS S 0300-N)

Aluminum shade: Ref. 4926.

- 10 White (NCS S 0300-N)
- 25 Beige D1 (NCS S 4005-Y50R)
- 28 Brown M1 (NCS S 4020-Y60R)
- 56 Green D1 (NCS S 7010-G30Y)

Finish customization  
 (Available options: Vibia colour palette)

Diffuser: PMMA  
 Canopy: Steel

LED light source

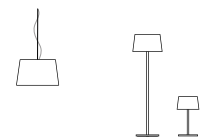

# Wireflow

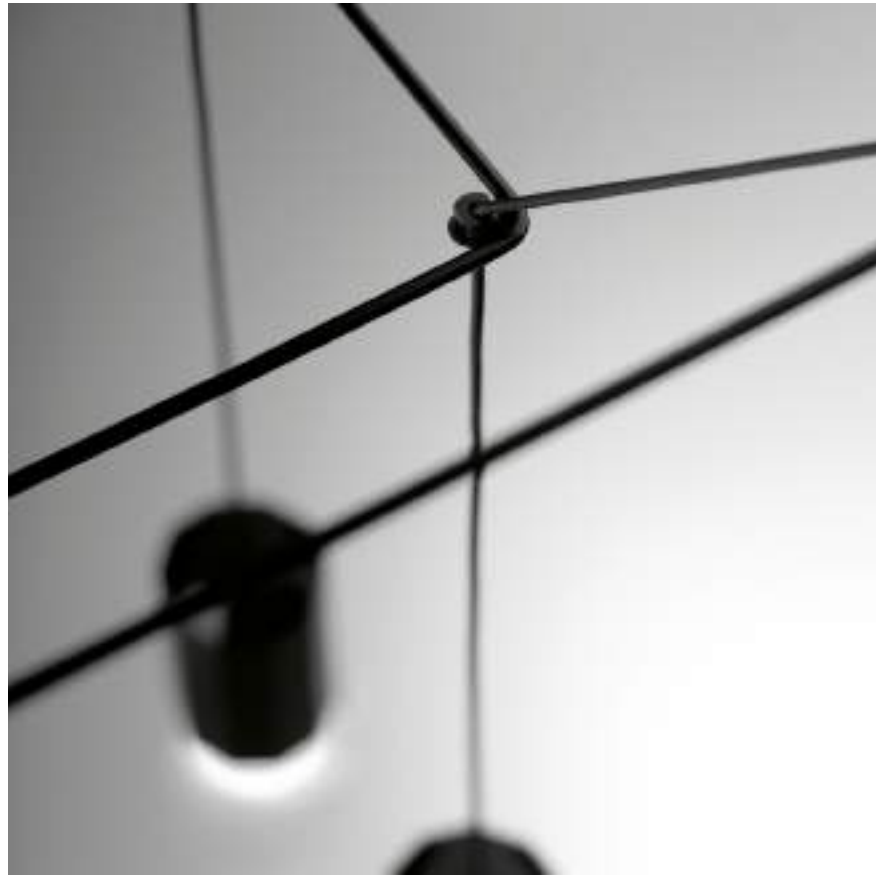

Design by Arik Levy.

Crafted of black, electrical cables, Volumetric's airy, three-dimensional outline lends it the feeling of being at once present and absent. The geometric volumes are tipped with LED light terminals in a contemporary take on the traditional chandelier.





Pressed-glass diffuser

Wireflow volumes for gathering spaces. Illuminate dining, living or working spaces of any scale with geometric shapes that provide a focal point without overpowering the space. Choose from multiple shapes and sizes, plus adjust lengths to suit individual tastes and project needs.

Create a personalized Wireflow pendant at [vibia.com](http://vibia.com)

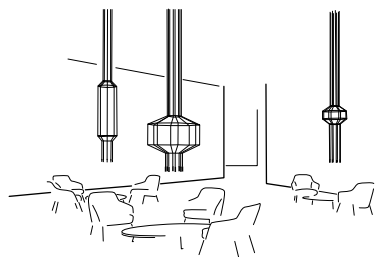

Characterised by its graphic style and simplicity of form, Wireflow traces three-dimensional geometries of steel and aluminum, which, despite their large scale, maintain a sense of weightlessness. Available in 4 and 8 diffuser versions, its distinctive volumetric aesthetic will draw the eye to specific focus points without visually overcomplicating an area.

● 04 Black (RAL 9005)

Diffuser: Pressed-glass  
Body: Aluminum  
Horizontal rods and Canopy: Steel

**LED Colour Temperature**  
2700 K; 3000 K; 3500 K  
CRI>90

**Control**  
Analog: Push; 1-10V  
Digital: DALI-2  
Smart: Casambi

4 LEDs

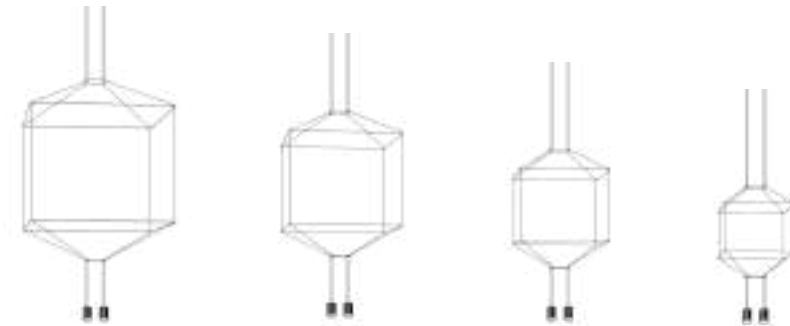

**0309**  
100 x 100 cm

**0310**  
80 x 80 cm

**0311**  
64 x 64 cm

**0312**  
50 x 50 cm

8 LEDs

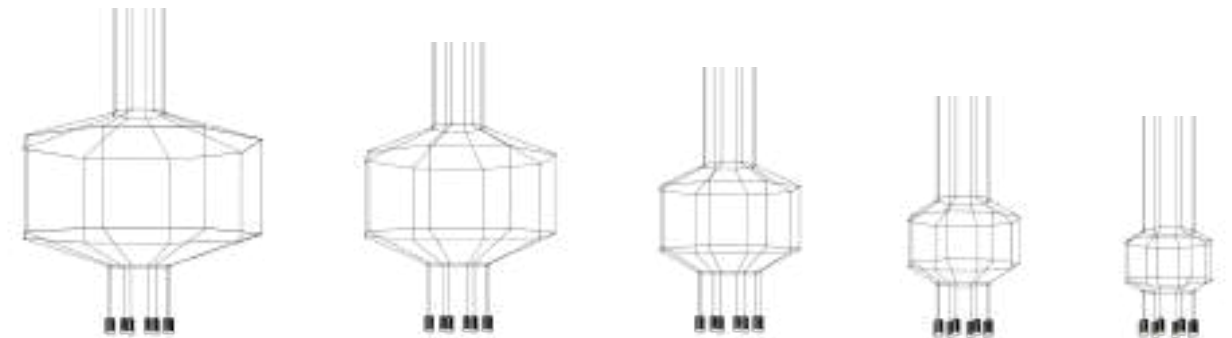

**0299**  
150 x 150 cm

**0300**  
120 x 120 cm

**0301**  
89 x 89 cm

**0302**  
70 x 70 cm

**0303**  
55 x 55 cm

# Wireflow Lineal

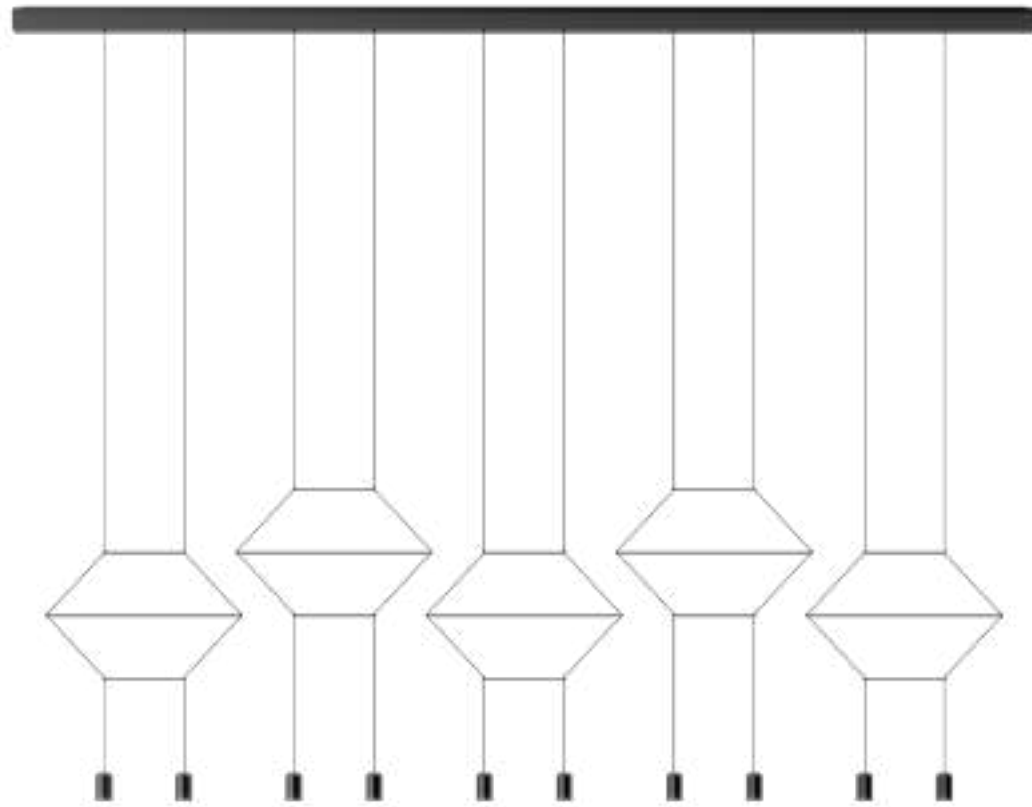

Design by Arik Levy.

Wireflow Lineal's ultra-minimalist design is balanced by a distinctive, precipitous presence that adds an intriguing accent to any room. Ideal for illuminating large spaces with high ceilings, its lean profile traces a formal silhouette in an open space with meticulous precision.



2 LEDs 0320

57 cm x max. 200 cm



6 LEDs 0338

145 cm x max. 200 cm

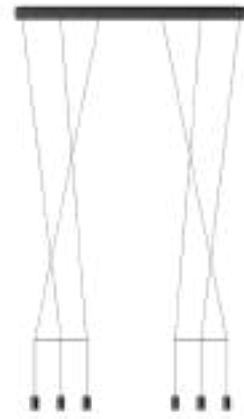

6 LEDs 0325

155 cm x max. 200 cm

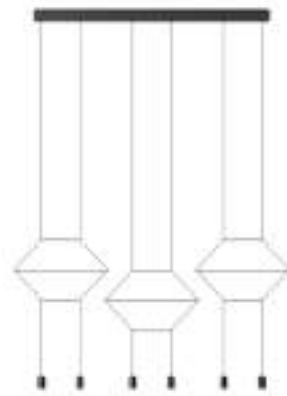

10 LEDs 0330

275 cm x max. 200 cm

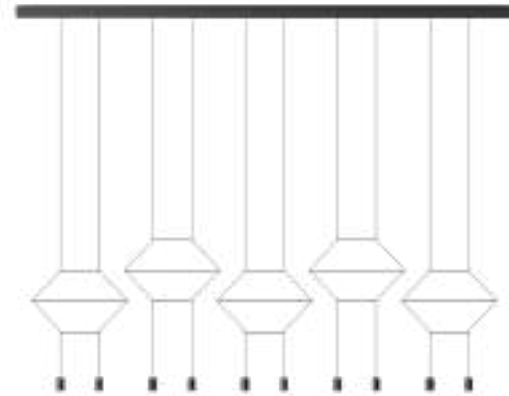

● 04 Black (RAL 9005)

Diffuser: PC- Polycarbonate  
Body and canopy: Aluminum  
Horizontal rods: Steel

**LED Colour Temperature**  
2700 K; 3000 K; 3500 K  
CRI>90

**Control**  
Analog: Push; 1-10V  
Digital: DALI  
Smart: Casambi

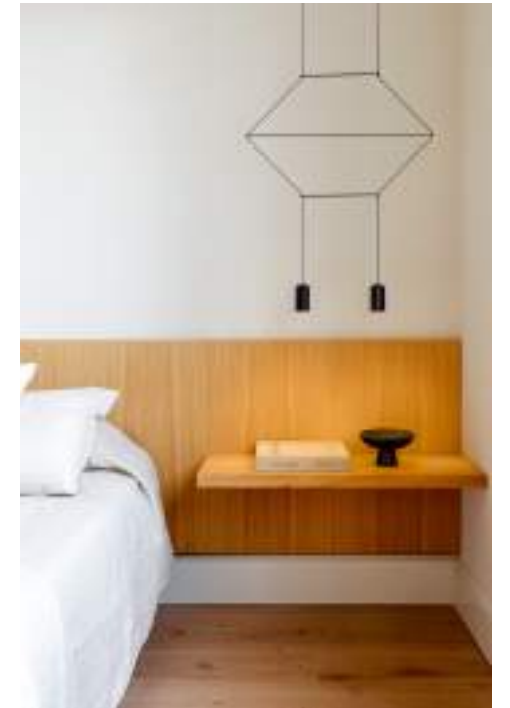

Wireflow lineal pendants for task lighting. Creative designs comprised of lineal black wires to subtly enhance a space over tables, reception desks and bars. Adjust top and bottom lengths for project needs.

Create your personalized Wireflow lineal at [vibia.com](http://vibia.com)





# Wireflow Free



Design by Arik Levy.

True to its name, Wireflow Free adapts easily to any environment. Its cables can be directed to form unexpected visual rhythms across a wall or ceiling, or to branch out from a central point and delineate specific activity zones within a space. Free offers maximum versatility in both form and function.

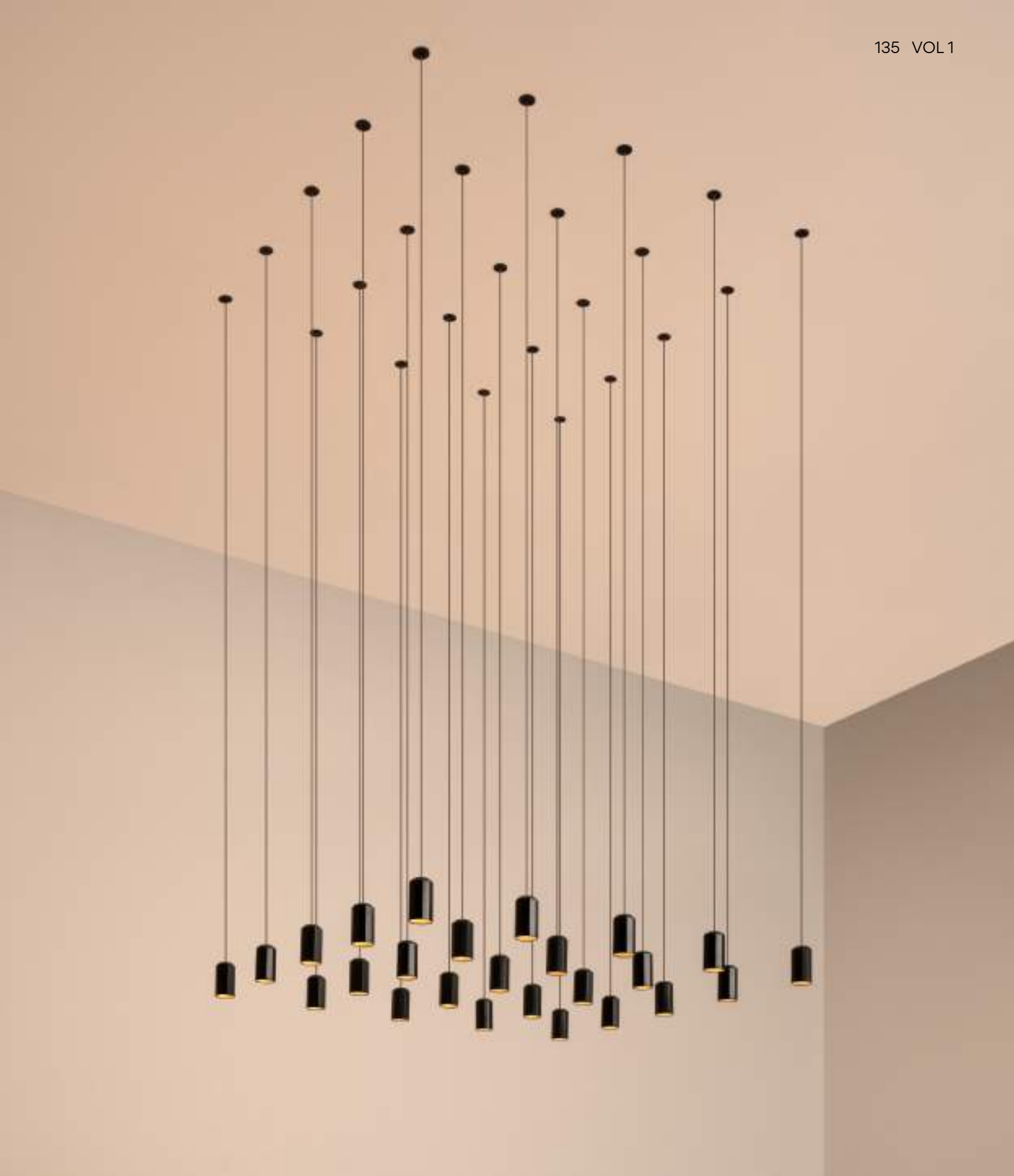



INDIVIDUAL MODEL

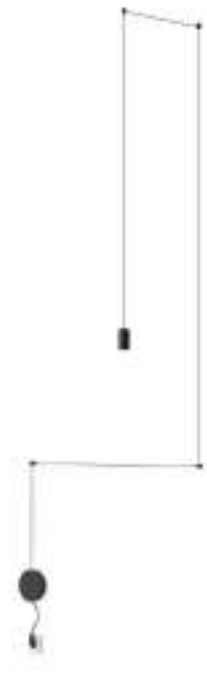

**0347**  
Ø 3 x 50 x 200cm



**0348**  
Ø 3 x 50 x 200cm



**0345**      **0361**  
Ø 3 x 200cm      Ø 3 x 200cm

● 04 Black (RAL 9005)

Diffuser: Pressed-glass / PC- Polycarbonate  
Body: Aluminum  
Canopy: Steel  
Ceiling supports: POM

**LED Colour Temperature**  
2700 K; 3000 K; 3500 K  
CRI>90

**Control**  
Analog: Push; 1-10V  
Digital: DALI-2  
Smart: Casambi

Ref. 0345 and 0348  
With pressed-glass diffuser  
Ref. 0361 and 0347  
Without pressed-glass diffuser,  
with polycarbonate diffuser

**Electrical connection options**



Remote



Built-in



Surface



Free Wire

MULTIPLE MODELS

Set your composition to [vibia.com](http://vibia.com)

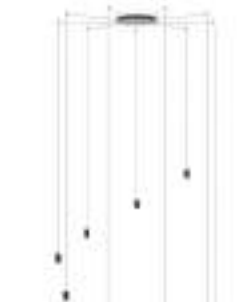
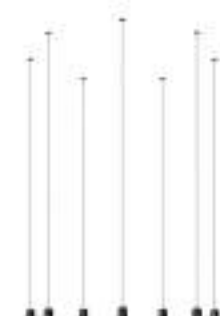
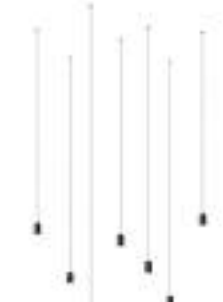

# Wireflow Chandelier



Design by Arik Levy.

Wireflow Chandelier is a contemporary reimagining of the traditional fixture. Its ultramodern silhouette provides an unexpected twist, while its graceful lines echo with a sense of timeless elegance. Though substantial in size its airy outline creates a feeling of transparency.



20 LEDs **0315**  
120 x 279 cm



42 LEDs **0376**  
150 x 112 cm

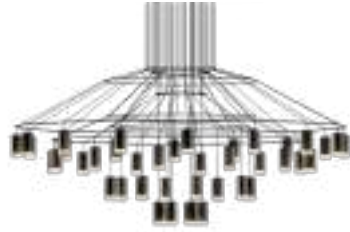

42 LEDs **0377**  
150 x 194 cm

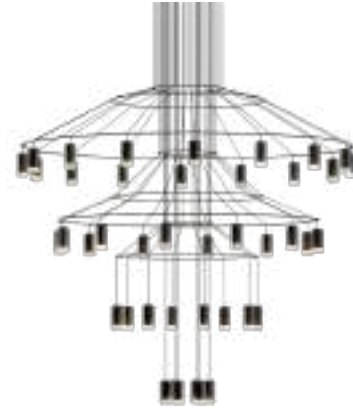

42 LEDs **0378**  
150 x 276 cm

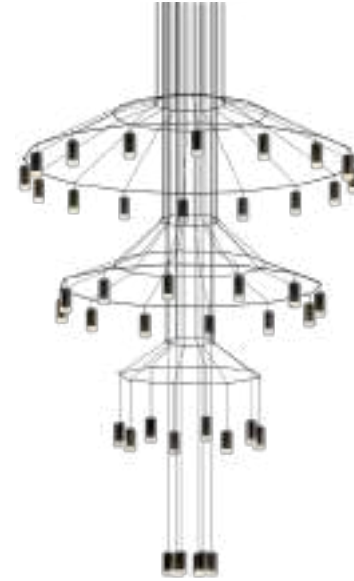

43 LEDs **0374**  
150 x 307 cm

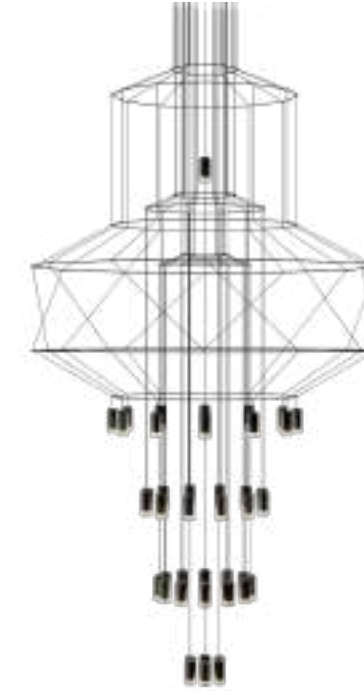

43 LEDs **0375**  
150 x 396 cm



Grandeur amplified. A focal point is created with Wireflow Chandelier for large spaces with this revamp of the classic chandelier. Large scale luminaire options based on project needs with height adjustability.

Select your favorites and personalize the height at [vibia.com](http://vibia.com)



● 04 Black (RAL 9005)

Diffuser: Pressed-glass  
Body: Aluminum  
Canopy and horizontal rods: Steel

**LED Colour Temperature**  
2700 K; 3000 K; 3500 K  
CRI>90

**Control**  
Analog: Push; 1-10V  
Digital: DALI-2  
Smart: Casambi

# Flamingo Mini



Design by Antoni Arola.

Flamingo Mini creates multi-layered silhouettes with an avant-garde, intriguing aesthetic. This hanging lamp recalls a bird hovering overhead, bringing an intimate ambience as it casts diffuse gradations of soothing light through its translucent diffuser.





The Flamingo Mini collection pairs poetic beauty with high quality performance. Its deconstructed design separates an LED light source from layers of translucent diffusers, producing soft gradations of illumination. The diffusers are available in a range of different configurations, each LED performing like a spotlight, directed upwards or downwards to produce an ambient effect.





1575

Ø 45 cm

1580

Ø 9 cm

1585

Ø 45 cm

1590

Ø 45 cm

Option A

Option B

Option C

Three options of installation

● 11 Black (NCS S 8500-N)

Diffuser: PMMA  
Rods: Stainless steel  
Body: Aluminum  
Canopy: ABS

LED Colour Temperature

2700 K  
CRI>90

Control

Analog: Push; 1-10V  
Digital: DALI-2  
Smart: Casambi

Electrical connection options



Built-in

Surface





# Flamingo



Design by Antoni Arola.

Displaying the elegant poise of the bird that inspired it, Flamingo projects a feeling of weightlessness hovering overhead. The deconstructed design separates the LED light source from its translucent shades, producing gradations of diffuse illumination.





1510  
Ø 70 cm



1527  
Ø 90 cm



1530  
Ø 90 cm



1540  
Ø 70 cm



1550  
Ø 90 cm



1560  
Ø 90 cm



1570  
Ø 90 cm



- 18 Graphite (RAL 7016)
- 20 Gold (Gold)
- 67 Copper (Copper)
- 93 White (RAL 9016)

Diffuser: PMMA  
 Body: Aluminum  
 Canopy and rods: Steel

**LED Colour Temperature**  
 2700 K; 3500 K  
 CRI>90

**Control**  
 Analog: Push; 1-10V  
 Digital: DALI-2  
 Smart: Casambi



# Cosmos

Design by Lievore, Altherr, Molina.

Design and light become one with the Cosmos collection. Flattened spheres suspended from slim cables create a cluster of pendant lights like a constellation of stars.





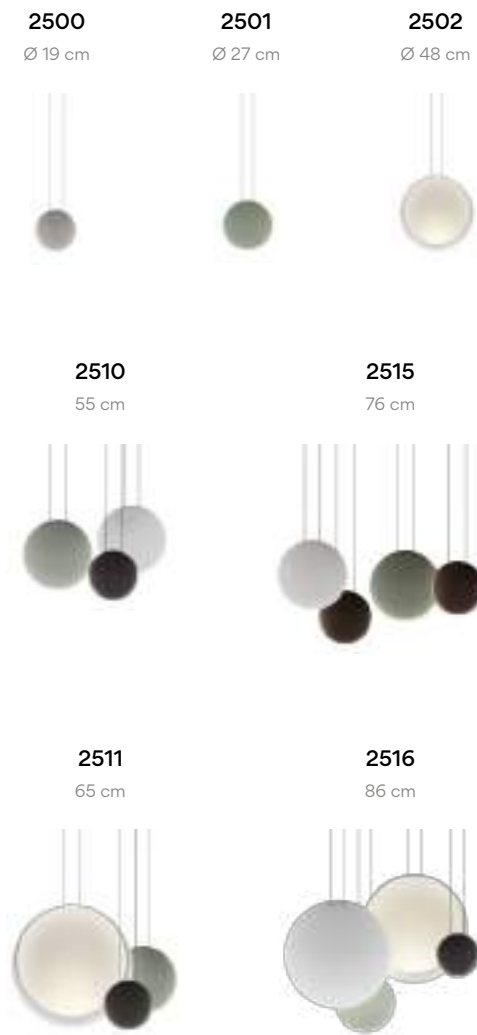

The minimalist, lacquered discs floating in space, their simple, sculptural curves and muted finishes, transmit a tranquil sensibility. LEDs are embedded within the opaque diffusers, unifying design and light source to generate a warm, indirect glow.

- 10 White (NCS S 0300-N)
- 14 Chocolate (RAL 8019)
- 58 Off-white (NCS S 2005-Y20R)
- 62 Green (Pantone 5645)

Diffuser: PC-Polycarbonate  
Canopy: Steel  
Body: PU - Polyurethane

#### LED Colour Temperature

2700 K; CRI >90  
3000 K; CRI >80

#### Control

Analog: On/ Off; Push; 1-10V  
Digital: DALI-2  
Smart: Casambi





# Match

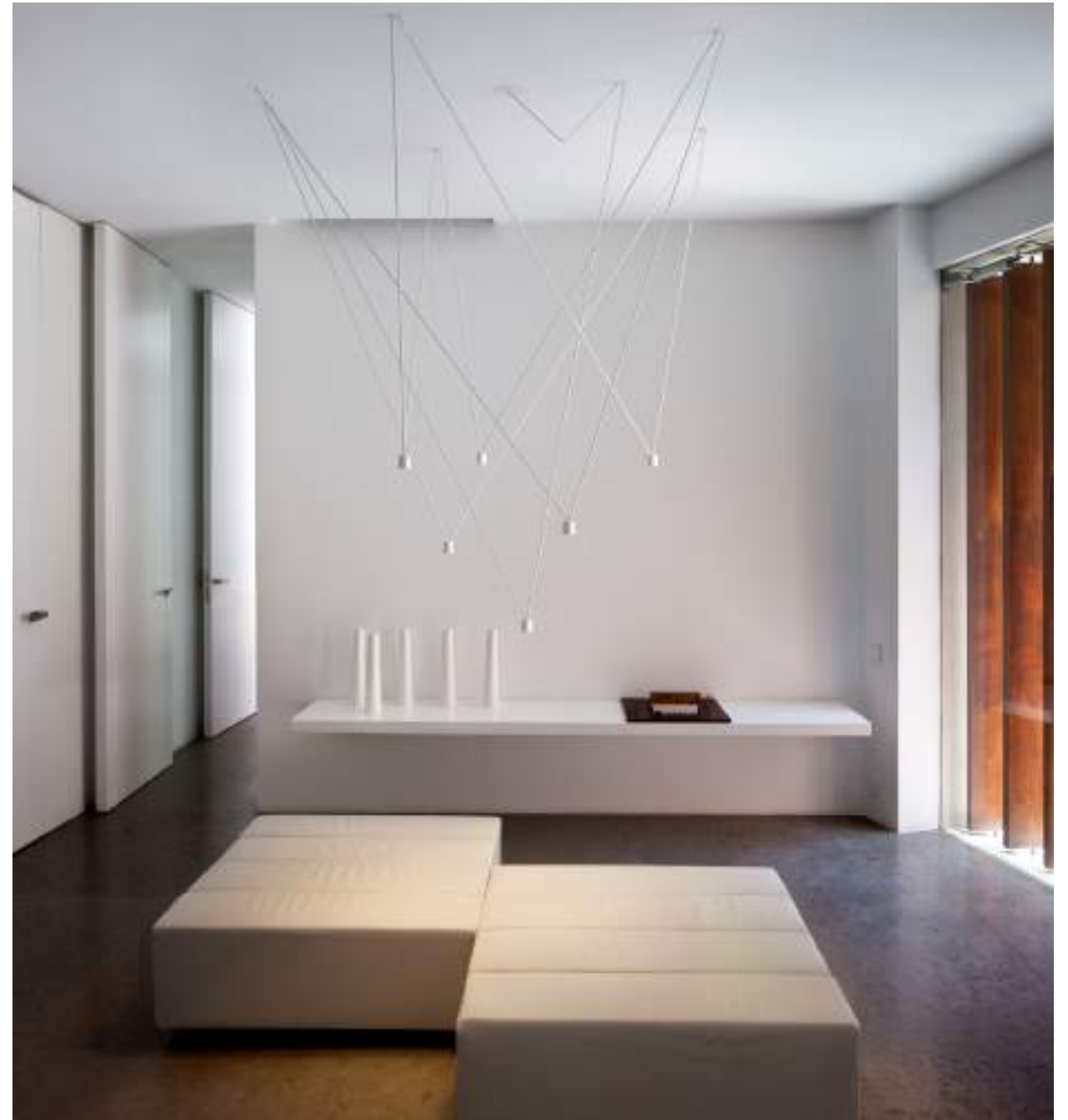

Design by Jordi Vilardell & Meritxell Vidal.

Based on the principle of co-creation, Match is a lighting collection that can be fully customised virtually. Characterised by unlimited configurations, Match's kinetic clusters exude a textured, sculptural presence.

Match is a unique pendant collection constructed from sleek aluminum rods finished in matt lacquered white or matt lacquered graphite and equipped with LED light terminals. Fully customisable, it is based on the concept of co-creation, taking on myriad forms to suit any space: from tight, concentrated clusters to sprawling configurations that span a larger area.

- 03 White (RAL 9016)
- 18 Graphite (RAL 7016)

Head: Aluminum  
Rods: Steel  
Canopy Plate: Steel

**LED Colour Temperature**  
2700 K; 3000 K; 3500 K  
CRI>80

#### Control

Analog: Push; 1-10V  
Digital: DALI-2  
Smart: Casambi

#### Personalization options available

Configuration layout at [vibia.com](http://vibia.com)  
Request more information

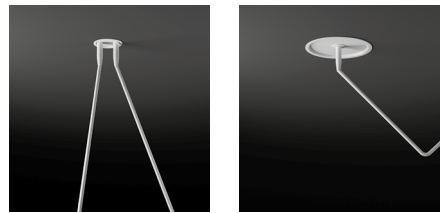

#### Built-in installation.

Electrical connection finials: the minimum height is 10 cm and the dimension of the cut-out is 10,5 cm.

Nodes: the minimum height is 12 cm and the dimension of the cut-out is 4,5 cm.

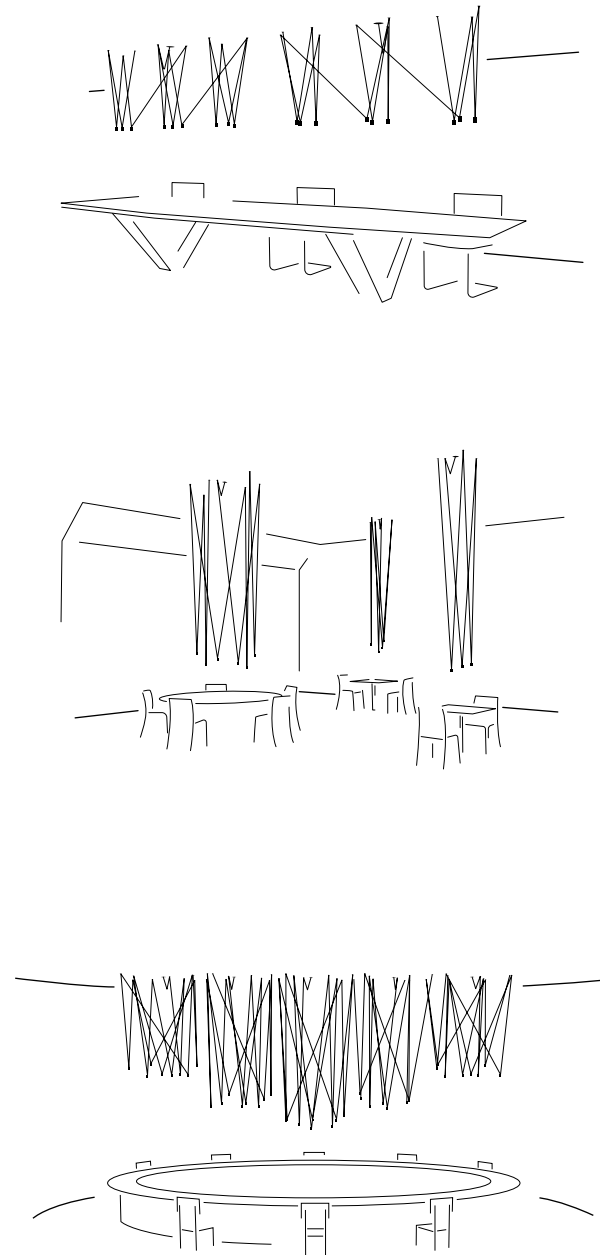

# Palma



Design by Antoni Arola.

The interior ambience takes on a life of its own with the possibility of integrating plants with the lighting compositions. Palma connects light and vegetation as in the natural landscape.



● 18 Graphite (ADAPTA RF 9913 WX)

Diffuser: Blown-glass  
Profile: Aluminum  
Planter: PMMA

**LED Colour Temperature**

2700 K  
CRI>90

**Control**

Analog: Push; 1-10V  
Digital: DALI-2  
Smart: Casambi

**3720**

Ø 25 cm



**3724**

Ø 25 cm



**3726**

Ø 25 cm



**3728**

Ø 25 cm



**3730**

Ø 25 cm

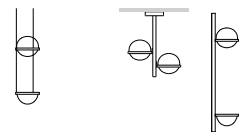

Pg 170 VOL 1 Pg 116/256 VOL 2



The floating effect is attained through its multiple configurations, the almost imperceptible suspension, a unique cable system and the hoops that wrap the spheres. Its capacity to create ambience increases with additional fixtures like a luminous hanging garden.

● 18 Graphite (ADAPTA RF 9913 WX)

Diffuser: Blown-glass  
Profile: Aluminum  
Planter: PMMA

**LED Colour Temperature**

2700 K  
CRI>90

**Control**

Analog: Push; 1-10V  
Digital: DALI-2  
Smart: Casambi

**3734**

150 cm

**3735**

150 cm

**3736**

195 cm

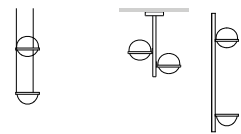
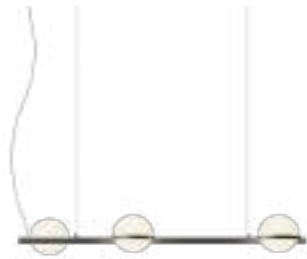

Pg 170 VOL 1 Pg 116/256 VOL 2



# Bigger



Design by La Invisible.

Bigger serves as statement lighting without overbearing the space it occupies, radiating with profuse light which cascades down from the ceiling, its impressive scale bringing the space to life.





**3920**  
Ø 80 cm  
7729 lm



**3925**  
Ø 84 cm  
7729 lm



**3930**  
Ø 103 cm  
14301 lm



**3935**  
Ø 107 cm  
14301 lm



- 23 Beige L1 (NCS S 0502-Y50R)
- 24 Beige M1 (NCS S 2005-Y50R)
- 37 Terra Red (NCS S 4040-Y70R)
- 53 Green M1 (NCS S 6005-G80Y)

Body: Aluminum  
Shade: Aluminum  
Diffuser: PC- Polycarbonate

**LED Colour Temperature**  
2700 K; 3500 K  
Tunable White (2200 K-4000 K)  
CRI>90

**Control**  
Analog: Push; 1-10V  
Digital: DALI-2  
Smart: Casambi

Vibia's general lighting, spot accent and downlight luminaires include the option of tunable white. Combining these zenithal tunable white lights with the rest of the diffused and indirect lighting effects of Vibia's portfolio, you can design the perfect scene for every moment and use.

**Tunable White (2200K - 4000K)**  
Tunable white lighting option allows for comprehensive temperature regulation depending on the atmosphere of every scene.

**Static White 2700K; 3500K**  
You can select the static white option that fits best with the desired ambience.

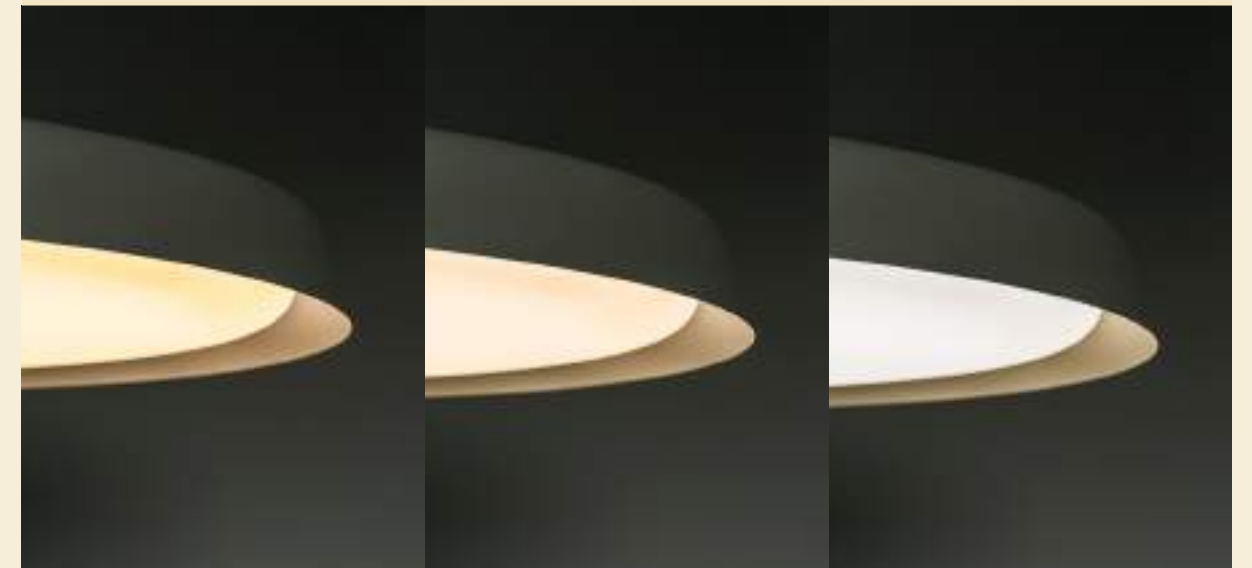

Contact Vibia Support Service at [vibia.com](http://vibia.com) for any kind of assistance or recommendation when designing an atmosphere of wellbeing, or if you require support with control system approach.



# Rhythm Horizontal



Design by Arik Levy.

Minimalist in form yet simultaneously complex, Rhythm features slender light modules of varying lengths, each fitted with an LED, that can be arranged in endless configurations. Fluid and flowing or angular and anarchic, the collection offers total freedom of composition.



### Wood

The collection includes the option of a natural wood in White oak or Walnut. Reflected in its textured surface, warm light bathes the space, producing a rich and restorative atmosphere.

- 82 White oak
- 83 American walnut

Stick: Wood  
Spacers: Aluminum  
Diffuser: PC-Polycarbonate  
Canopy: Steel

**LED Colour Temperature**  
2700 K; 3500 K  
CRI>90

**Control**  
Analog: 1-10V  
Digital: DALI-2  
Smart: Casambi

**Electrical connection options**



Built-in    Surface

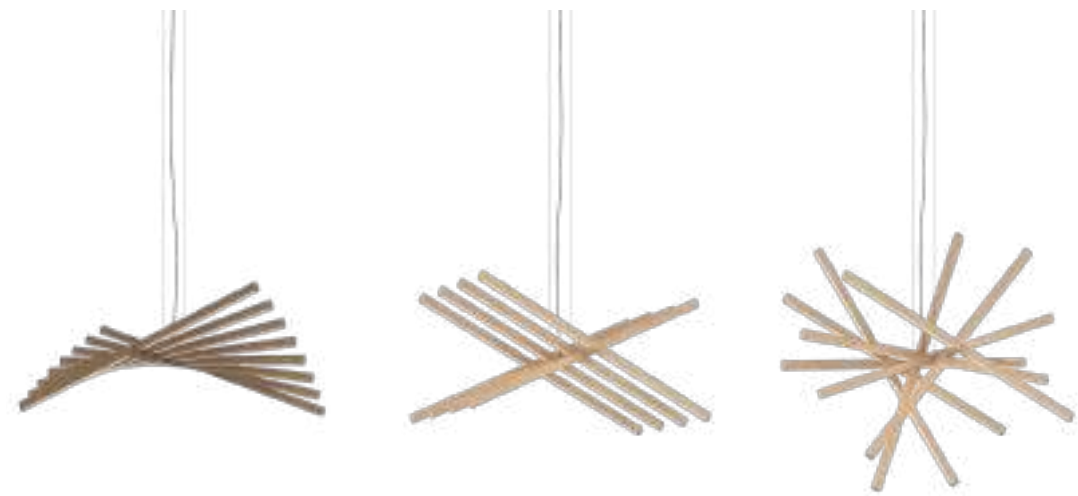

Stick 87 cm

**2155**

49 x 87 cm



### Basic

Its unique rotation system allows the light sticks to move along a horizontal axis, positioned in any direction to provide ambient downward illumination from above.

- 14 Chocolate (RAL 8019)
- 58 Off-white (RAL D2 1109005)

Stick: PA- Polyamide  
 Diffuser: PC- Polycarbonate  
 Canopy: Steel

**LED Colour Temperature**  
 2700 K; 3500 K  
 CRI>90

**Control**  
 Analog: 1-10V  
 Digital: DALI-2  
 Smart: Casambi

— **Electrical connection options**



Built-in    Surface

Stick 47 cm



**2110**  
45 x 47 cm

**2111**  
93 x 47 cm

**2112**  
141 x 47 cm

**2113**  
189 x 47 cm

Stick 87 cm



**2120**  
63 x 87 cm

**2121**  
131 x 87 cm

**2122**  
199 x 87 cm



# Rhythm Vertical



Design by Arik Levy.

Evoking the mood of Zen minimalism, Rhythm features slender light modules of varying lengths, each fitted with an LED module, that can be arranged in endless configurations.



### Wood

The collection includes the option of a natural wood in White oak or Walnut. Reflected in its textured surface, warm light bathes the space, producing a rich and restorative atmosphere.

- 82 White oak
- 83 American walnut

Stick: Wood  
Spacers: Aluminum  
Diffuser: PC-Polycarbonate  
Canopy: Steel

#### LED Colour Temperature

2700 K; 3500 K  
CRI>90

#### Control

Analog: 1-10V  
Digital: DALI-2  
Smart: Casambi

#### Electrical connection options



Built-in    Surface

Stick 87 cm

**2165**  
87 x 52,5 cm



**2167**  
87 x 81 cm





### Basic

A luminous sculpture suspended in space, Rhythm can be suspended vertically to provide ambient uplighting.

- 14 Chocolate (RAL 8019)
- 58 Off-white (RAL D2 1109005)

Stick: PA- Polyamide  
Diffuser: PC-Polycarbonate  
Canopy: Steel

**LED Colour Temperature**  
2700 K; 3500 K  
CRI>90

**Control**  
Analog: 1-10V  
Digital: DALI-2  
Smart: Casambi

#### Electrical connection options



Built-in    Surface

**2141**  
47 x 108 cm

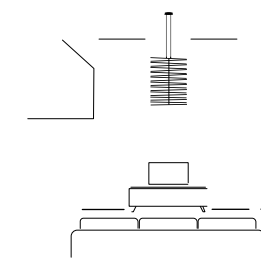

**2142**  
47 x 163,5 cm

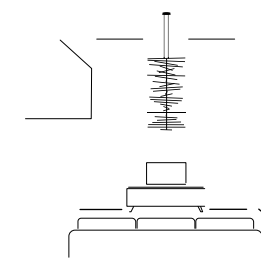

**2143**  
47 x 219 cm

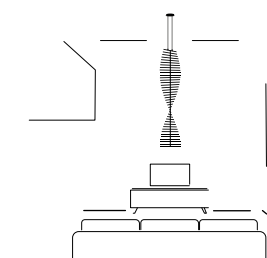

# Mayfair



Design by Diego Fortunato.

A modern reimagining of the traditional 19th-century bouillotte lamp, the Mayfair collection is a statement in contemporary design. Perfectly proportioned, its luminaire casts a pool of diffuse, downward light to create an intimate lighting effect.





Featuring a steel or methacrylate diffuser, the LED-powered pendant lamp is distinguished by its timeless style and sleek silhouette. Available in a range of striking colours, it casts a warm ambient glow that's ideal for relaxed interior lighting.





INDIVIDUAL MODEL



**5525**   **5520**  
 Ø 30 cm   Ø 30 cm

PMMA shade: Refs. 5520

- 07 Graphite and green (RAL 7016 and RAL 6026)
- 08 Graphite and orange (RAL 7016 and RAL 2009)

Steel shade: Refs. 5525

- 20 Gold (Gold)
- 67 Copper (Copper)

- 18 Graphite (RAL 7016)
- 23 Warm White (NCS S 0502-Y50R)
- 25 Beige D1 (NCS S 4005-Y50R)
- 38 Terra Dark (NCS S 5040-Y70R)
- 47 Green L1 (NCS S 4005-G80Y)

Finish customization  
 (Available options: Vibia colour palette)

Diffuser: PC-Polycarbonate  
 Tube and canopy: Steel

**LED Colour Temperature**

LED 2700 K  
 CRI >90

**Control**

Individual model  
 Analog: Push; 1-10V  
 Digital: DALI-2  
 Smart: Casambi

**Electrical connection options**



Remote   Built-in

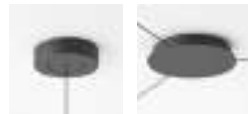

Surface   Free Wire

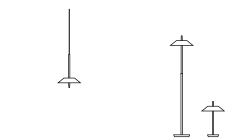

Pg 194 VOL 1   Pg 394 VOL 1

MULTIPLE MODELS

Set your composition to [vibia.com](http://vibia.com)



# Algorithm Free

Design by Toan Nguyen.

Like a cloud of frozen rain, this collection brings together beauty and geometry. Each unique grouping of globes defines areas of interior space, underlining their multiple uses while becoming a single aesthetic element.





INDIVIDUAL MODEL

MULTIPLE MODELS

Set your composition to [vibia.com](http://vibia.com)



**O820**  
Ø 9 cm

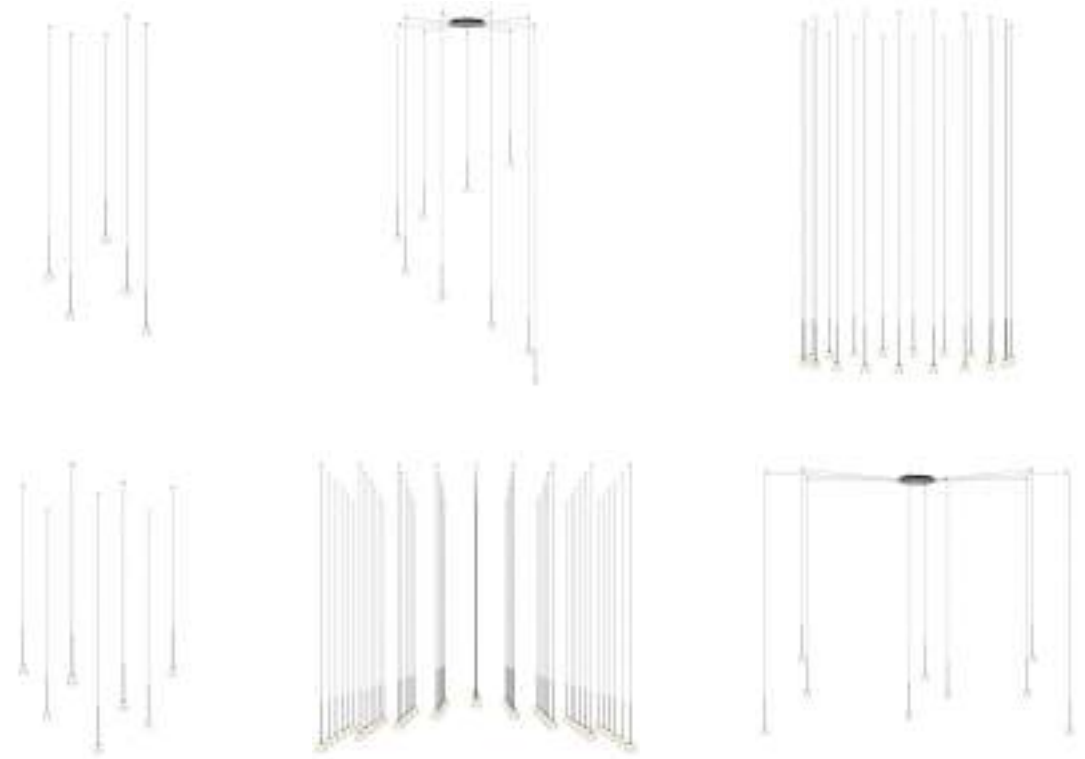
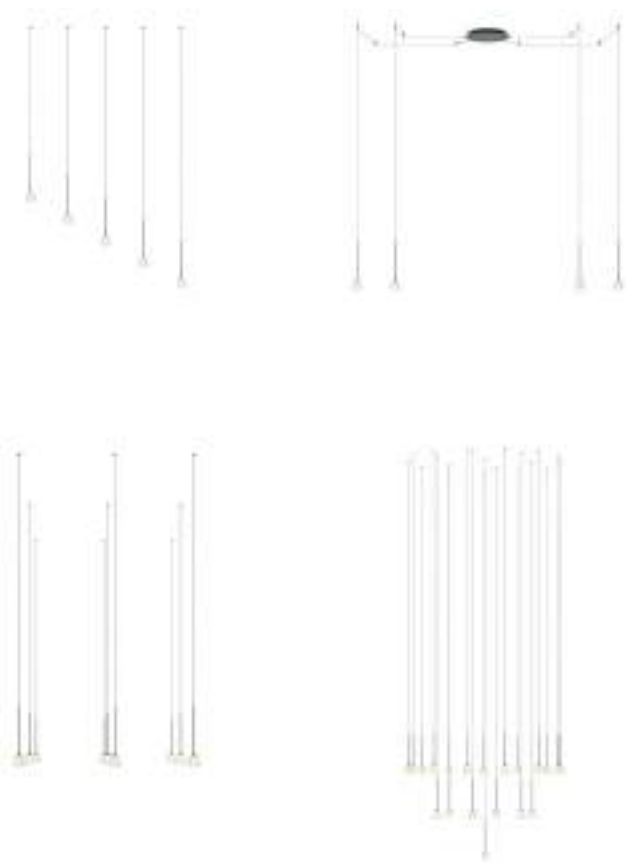

● 18 Graphite (ADAPTA RF 9913 WX)

Sphere: Blown-glass  
Diffuser: PC- Polycarbonate  
Glass fastening: Aluminum  
Canopy: Steel  
Pendant structure: Steel  
LED support: Aluminum

**LED Colour Temperature**

2700 K; 3500 K  
CRI >90

**Control**

Analog: Push; 1-10V  
Digital: DALI-2  
Smart: Casambi

**Electrical connection options**



Remote

Built-in



Surface

Free Wire



# Algorithm Grid



Design by Toan Nguyen.

Like a cloud of frozen rain, this collection brings together beauty and geometry. Mathematical order provides a magical harmony with an astonishing range of permutations and compositions. Can be customized to suit any space.



Algorithm resembles a sparkling constellation of illuminated drops that appear to float in mid-air. Evoking a mood that's equal parts mathematical and magical, the pendant is anchored to the ceiling from a tubular steel lattice. Sleek tensile cables are studded with glowing, handblown glass orbs powered by LEDs and suspended at different heights. Fully customisable, each unique grouping of globes defines areas of interior space, underlining their multiple uses while becoming a single aesthetic element.

● 18 Graphite (ADAPTA RF 9913 WX)

Sphere: Blown-glass  
Diffuser: PC- Polycarbonate  
Glass fastening: Aluminum  
Canopy: Steel  
Pendant structure: Steel  
LED support: Aluminum

#### LED Colour Temperature

2700 K; 3500 K  
CRI >90

#### Control

Individual model  
Analog: Push; 1-10V  
Digital: DALI-2  
Smart: Casambi

Create your personalized Algorithm at [vibia.com](https://vibia.com)

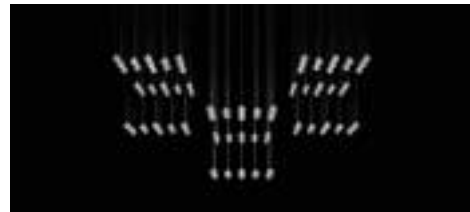

0825 0827\* 10 LEDs 75 x 85 cm



0830 0832\* 6 LEDs 123 x 25 cm  
0835 0837\* 10 LEDs 214 x 25 cm

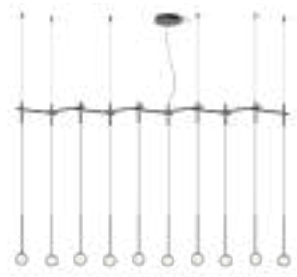

0840 0842\* 14 LEDs 306 x 25 cm  
0845 0847\* 14 LEDs 183 x 34 cm  
0850 0852\* 29 LEDs 399 x 34 cm



0860 0862\* 13 LEDs 110 x 110 cm  
0865 0867\* 25 LEDs 160 x 160 cm



0870 0872\* 15 LEDs 110 x 60 cm  
0875 0877\* 24 LEDs 185 x 60 cm



\* Built-in canopy



# Slim



Design by Jordi Vilardell.

Streamlined and refined, Slim serves as a sleek punctuation mark.





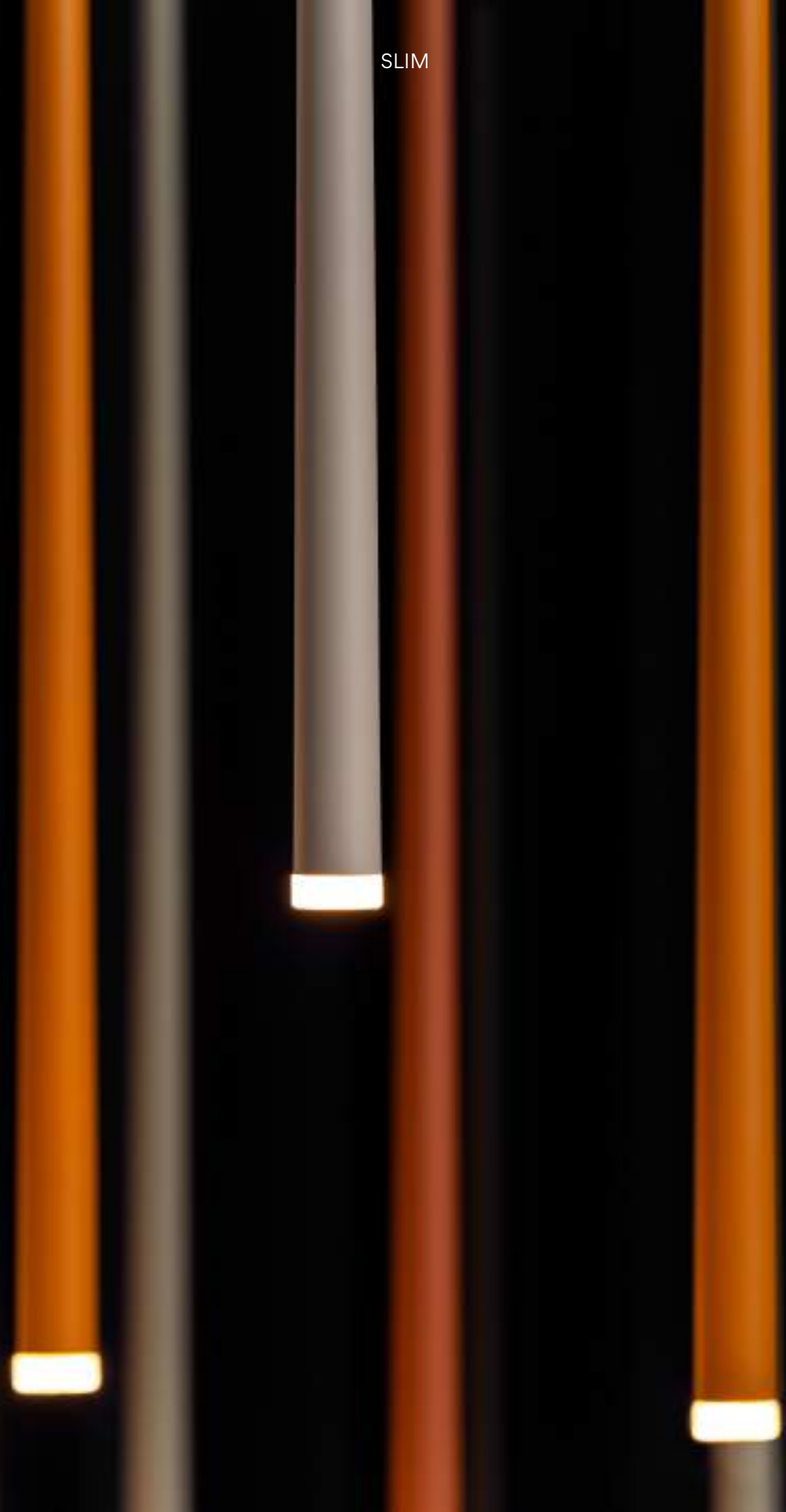

Distinguished by long, slender strands suspended from fibre cords, Slim draws the eye upwards like drops of light falling from the sky. Crafted of patterned glass diffusers, it lends a candlelit ambience that bathes a space in a soft pool of light thanks to its LED fittings.

INDIVIDUAL MODEL



0920  
Ø ,6 cm

MULTIPLE MODELS

Set your composition to [vibia.com](http://vibia.com)

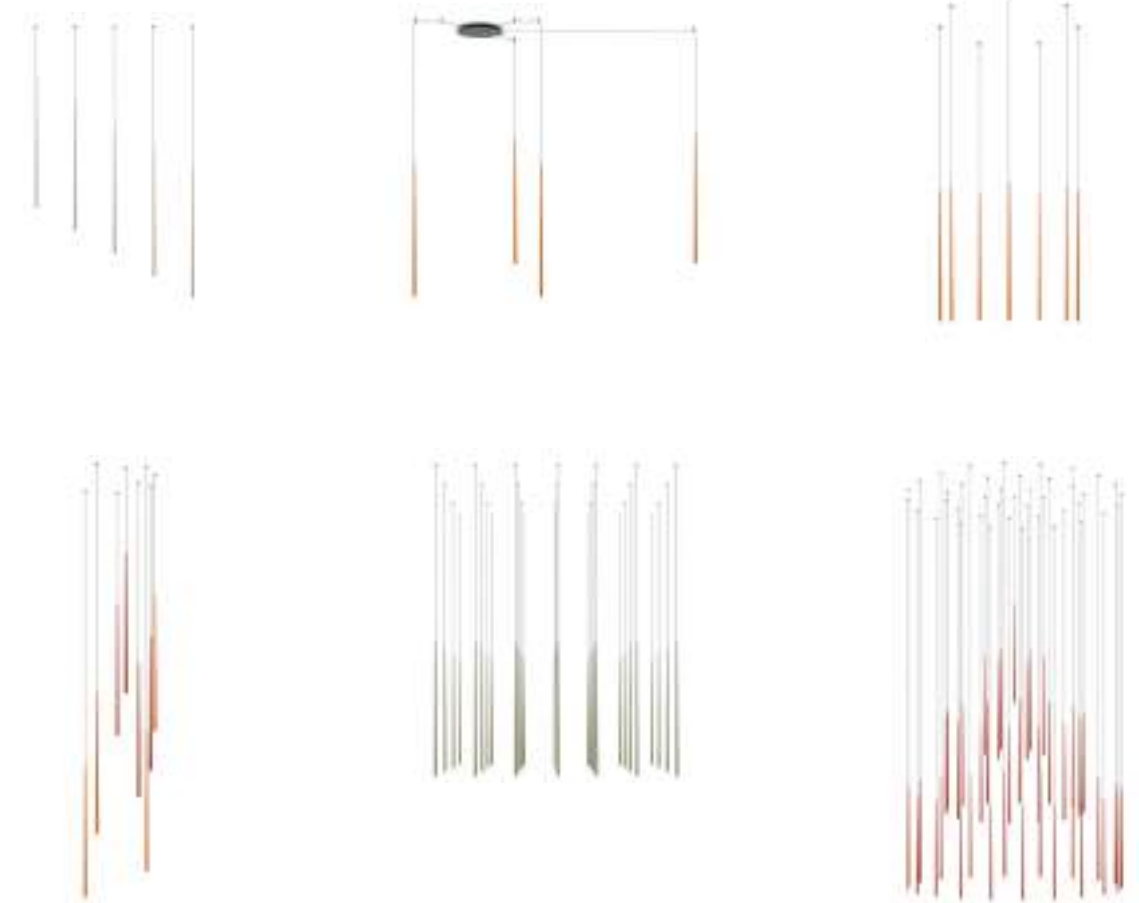
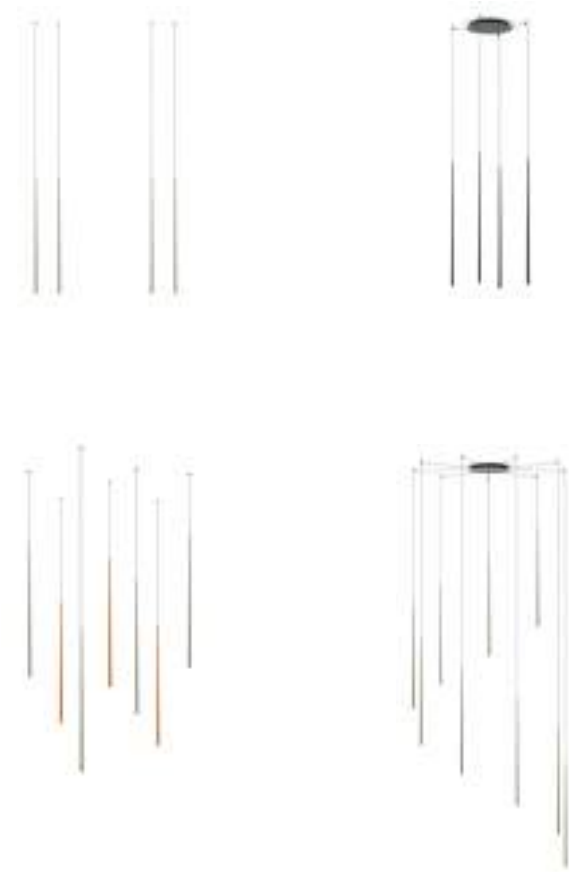

- 10 White (NCS S 0300-N)
- 11 Black (NCS S 8500-N)
- 24 Beige M1 (NCS S 2005-Y50R)
- 37 Terra Red (NCS S 4040-Y70R)
- 47 Green L1 (NCS S 4005-G80Y)
- 68 Ocre (NCS S 3050-Y30R)

**LED Colour Temperature**

2700 K; CRI >90  
3000 K; CRI >80  
3500 K; CRI >90

**Control**

Analog: On/ Off; Push; 1-10V  
Digital: DALI-2  
Smart: Casambi

**Electrical connection options**



**BIND related product**



Finish customization  
(Available options: Vibia colour palette)

Diffuser: Glass  
Body: FB- Fiberglass  
Canopy: Steel



# Halo



Design by Martín Azúa.

A seamless merging of light and matter, Halo lends the effect of light floating in air. Powered by LED bulbs that remain invisible within their opalized, linear moulds, the light flows freely from its source.

2340  
2 units



2341  
3 units



● 03 White (RAL 9016)

Diffuser: PMMA  
Canopy: Steel



**LED Colour Temperature**  
2700 K; 3000 K  
CRI >90

**Control**  
Analog: 1-10V  
Digital: DALI-2  
Smart: Casambi

— **Electrical connection options**

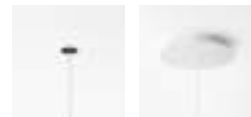

Remote    Surface

2342  
6 units

2343  
9 units

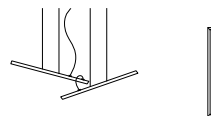
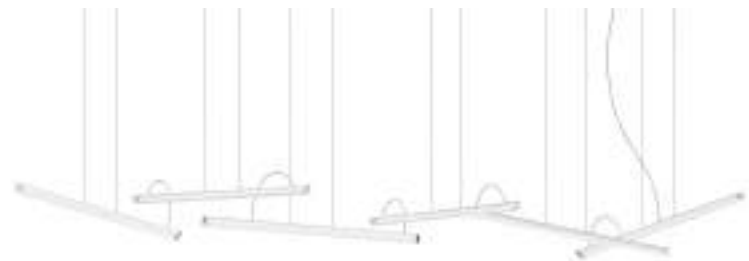

● 03 White (RAL 9016)

Diffuser: PMMA  
Canopy: Steel  
LED support: Aluminum

**LED Colour Temperature**

2700 K; 3000 K  
CRI >90

**Control**

Analog: 1-10V  
Digital: DALI-2  
Smart: Casambi

Surface mounted

**2330**

Ø 55,5 cm



**2331**

2 units



**2332**

3 units



**2333**

5 units

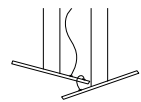

# Halo Jewel



Design by Martín Azúa.

Subtle light floating in the air and delicately suspended by a perfectly crafted steel structure. Light and matter in one.



INDIVIDUAL MODEL



- 11 Black (NCS S 8500-N)
- 20 Gold (Gold)

Canopy: Steel  
 Pendant structure: Steel  
 Diffuser: Methacrylate  
 LED support: Aluminum

**LED Colour Temperature**  
 2700 K; 3000 K  
 CRI >90

**Control**  
 Analog: 1-10V  
 Digital: DALI-2  
 Smart: Casambi

Electrical connection options

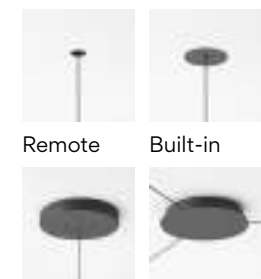

Remote

Built-in

Surface

Free Wire

MULTIPLE MODELS

Set your composition at [vibia.com](http://vibia.com)



INDIVIDUAL MODEL



MULTIPLE MODELS

Set your composition at [vibia.com](http://vibia.com)



- 11 Black (NCS S 8500-N)
- 20 Gold (Gold)

Canopy: Steel  
 Pendant structure: Steel  
 Diffuser: Methacrylate  
 LED support: Aluminum

**LED Colour Temperature**  
 2700 K; 3000 K  
 CRI >90

**Control**  
 Analog: 1-10V  
 Digital: DALI-2  
 Smart: Casambi

Ref. 2355.  
**Electrical connection options**

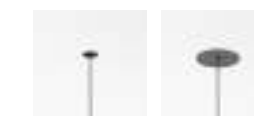

Remote

Built-in

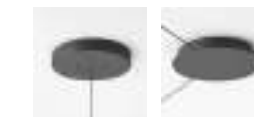

Surface

Free Wire



# Wind

Design by Jordi Vilardell.

A perfect marriage of technology and tradition. Wind's drum shade is made of fibreglass, an innovative webbed texture and pattern that elevates the visual contribution of this timeless silhouette.



- 27 Sand (NCS S 1505-Y50R)
- 53 Green M1 (NCS S 6005-G80Y)
- 61 Ocre Red (NCS S 3050-Y60R)

Shade: FB- Fiberglass  
 Canopy: Steel  
 Lid: Steel  
 Diffuser: PMMA

**LED Colour Temperature**  
 2700 K  
 CRI >90

**Control**  
 Analog: On/ Off

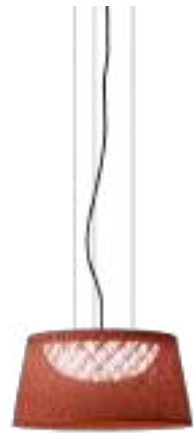

**4072**  
 Ø 60 cm



**4077**  
 Ø 60 cm



**4078**  
 Ø 120 cm

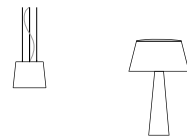

Pg 230 VOL 1 Pg 422 VOL 2  
 Pg 422 VOL 2



# Tempo



Design by Lievore Altherr.

The Tempo collection reclaims our collective memory of light, distilling lighting archetypes to their most basic forms. Vibia presents three designs in two sizes: the disc, the diamond and the milk glass oval - all inspired by the interplay of opacity, translucence and transparency.





The Tempo pendant lamp collection integrates perfectly into all types of spaces and contemporary interior design projects. Suspended from the ceiling by a slim cable, its blown glass diffusers offer subtle nuances of transparency and translucency.



INDIVIDUAL MODEL

5776

Ø 40 cm



5770

Ø 25 cm



5778

Ø 24 cm



5772

Ø 13 cm



5780

Ø 34,5 cm



5774

Ø 20,5 cm



Pg 234 VOL 1



Pg 226 VOL 2

MULTIPLE MODELS

Set your composition at [vibia.com](http://vibia.com)

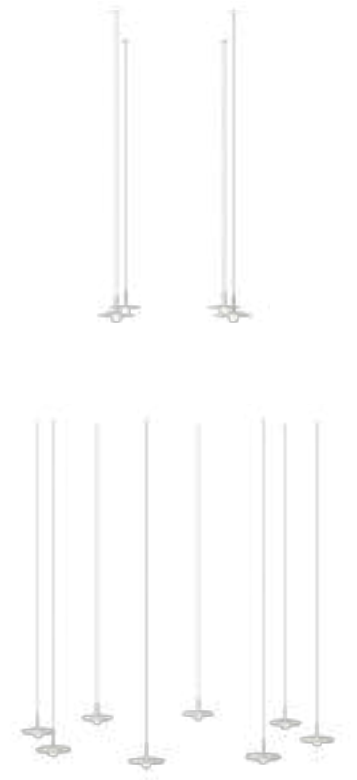

The classic bistrot globe has evolved with an oval organic shape with a gradated lighting that crosses the spectrum from transparency to translucence. The opaline diamond shade illuminates with a diffused light of superior quality. The model with the reflector plate converts the bulb into a small brilliant bubble that radiates light.

- 18 Graphite (ADAPTA RF 9913 WX)
- 37 Terra Red (NCS S 4040-Y70R)
- 58 Cream (RAL 7044)
- 62 Green (NCS S 3010-G20Y)

Diffuser: Blown-glass  
Canopy: Steel  
LED support: Aluminum  
Shade: Aluminum

**LED Colour Temperature**  
2700 K  
CRI >90

**Control**  
Analog: Push; 1-10V  
Digital: DALI-2  
Smart: Casambi

Electrical connection options

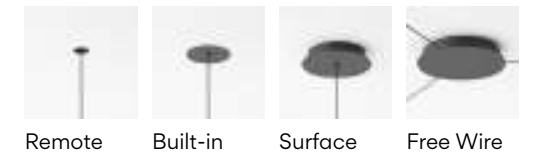

BIND related product



# Bind

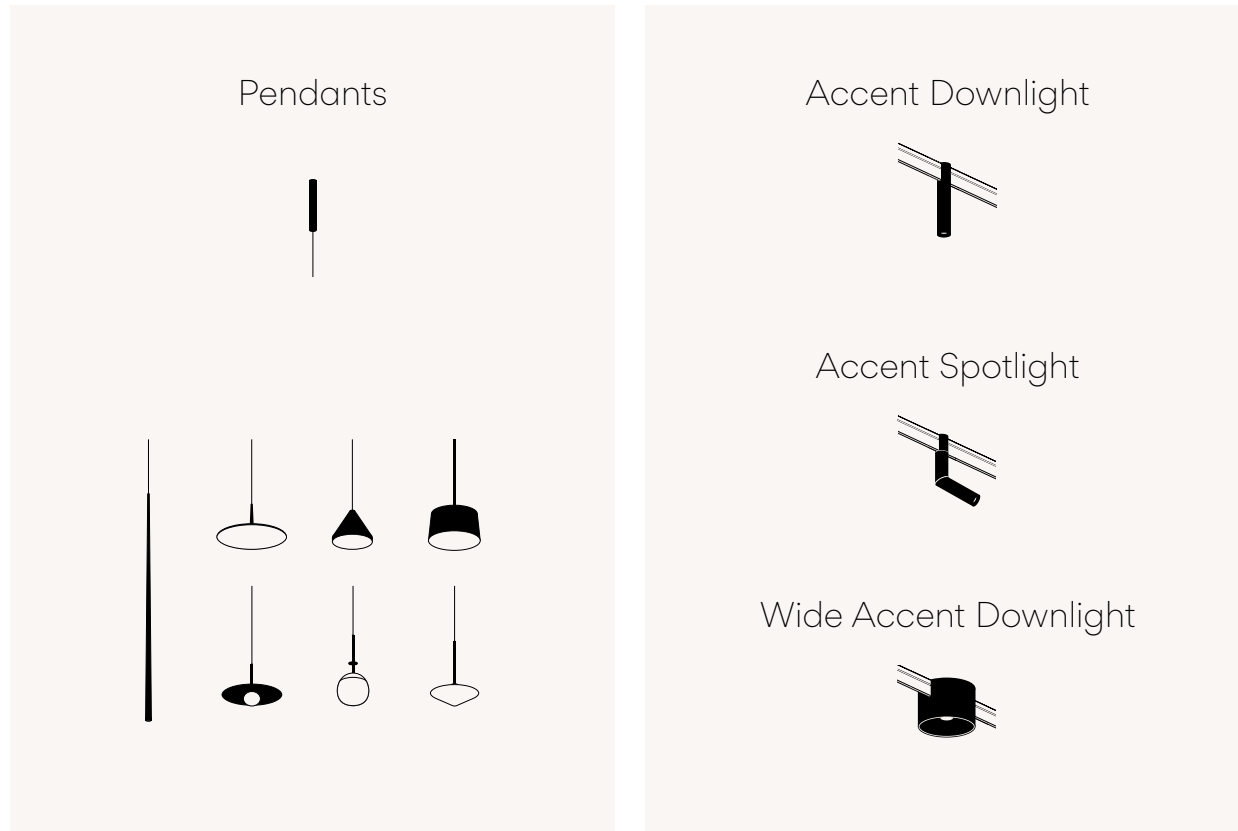

Design by Martín Azúa.

Bind is a hybrid lighting system designed to create multiple atmospheres to suit a range of spaces, uses and moods. The connective quality, ease of installation and versatility of this fully modular system guarantees a harmonious balance between technical and decorative lighting, promising new holistic lighting solutions.





Bind easily integrates within the existing architecture; as a ceiling or suspended track, it allows designers to experiment with horizontal planes, ideal for spaces with high ceilings where it is necessary for light to be conducted to a lower height; and, as a hybrid combination, the collection lends itself to complex compositions of various atmospheres.









To highlight a particular activity zone or feature within the space, Bind track is also compatible with a series of spots and downlights that provide functional, accented lighting.





Multiple luminaires can be seamlessly connected to the track at any point, oriented to direct light in various directions. The different pieces are made in pincer format to be applied at any point of the track and move easily and immediately as desired.

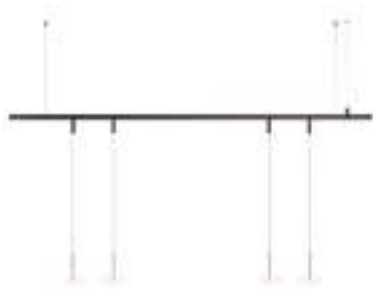



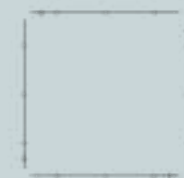
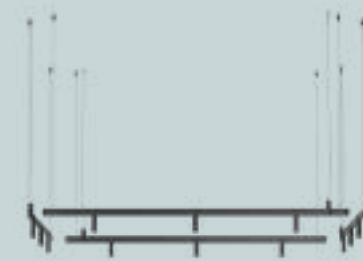

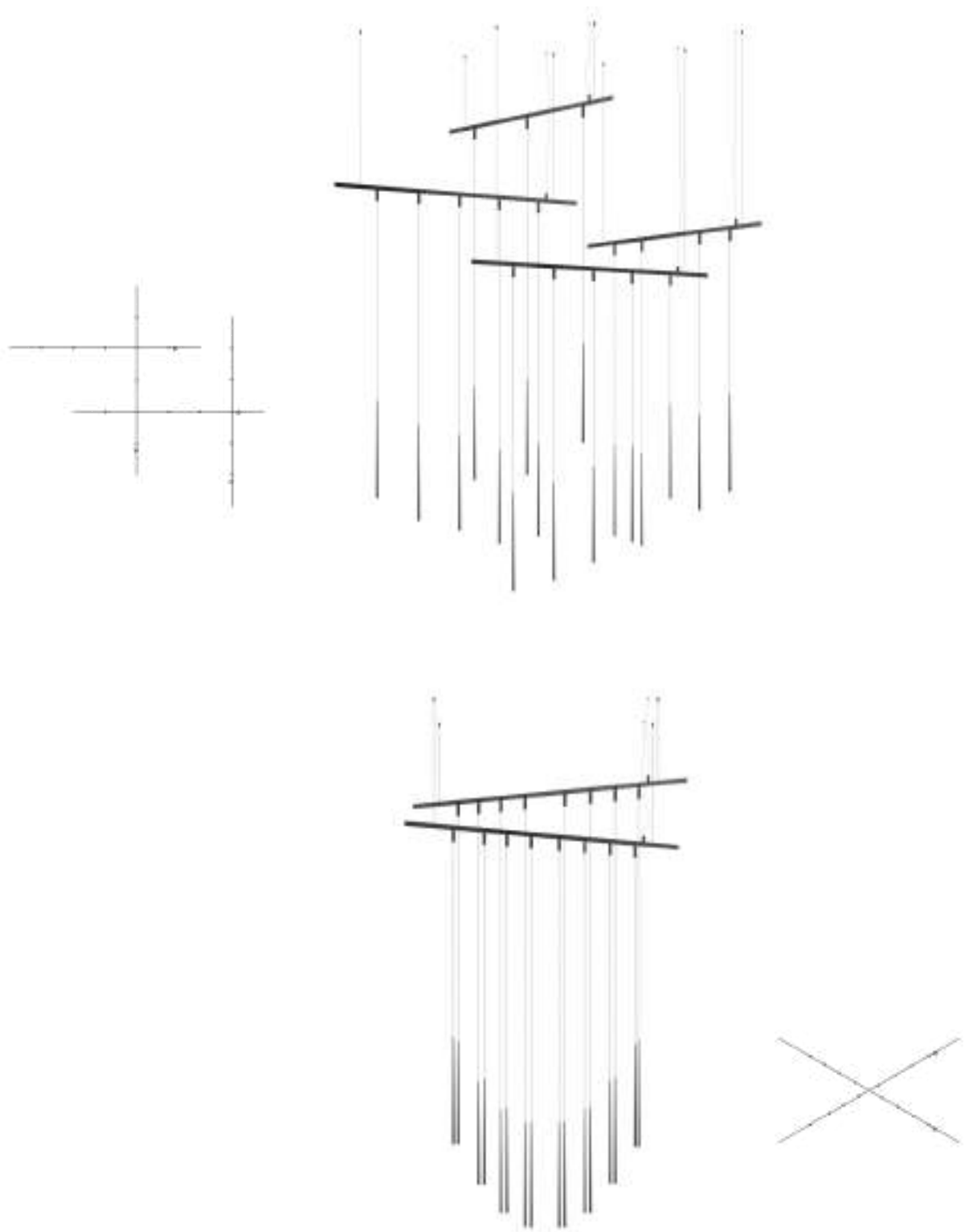

The Bind collection features ceiling surface and ceiling suspended track lighting, where a conductive bar or "track" represents the central element from which multiple luminaires can be fixed at any point. Bind track is compatible with a series of spots, downlights, lineal and general lighting fixtures that provide all types of functional lighting.

- 11 Black (NCS S 8500-N)
- 24 Beige M1 (NCS S 2005-Y50R)

Body: Aluminum  
Diffuser: PC- Polycarbonate

**LED Colour Temperature**

Ø 3 cm  
Static White  
2700 K - 451 lm  
3000 K - 471 lm  
3500 K - 489 lm  
4,3W

Ø 4 cm  
Static White  
2700 K - 530 lm  
3000 K - 554 lm  
3500 K - 574 lm  
5,2W

Only ref. 6525, 6529, 6534 and 6538  
Tunable White (1800 K - 4000 K)  
Smart (P2P)  
308 lm - 504 lm 5,5W

Ø 18,5 cm  
Static White  
2700 K - 1256 lm  
3000 K - 1313 lm  
3500 K - 1360 lm  
12,4W

Tunable White (1800 K - 4000 K)  
Smart (P2P)  
571 lm - 895 lm 8,9W

CRI>90

**Control**

Analog: On/Off; Push; 1-10V (simultaneous line)  
Digital: DALI-2 (simultaneous line)  
Smart: Casambi (simultaneous line);  
Casambi (P2P); ProtoPixel\* (P2P)

\*ProtoPixel products are compatible with all other DALI-2 products via a designated gateway (please consult us)

Updated detailed spec sheets on [vibia.com](http://vibia.com)

Wide Accent Downlight

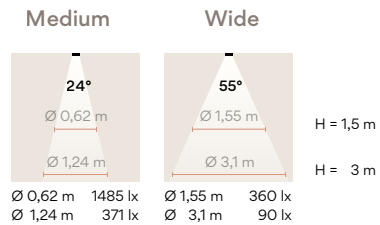

Accent Downlight



Accent Spotlight

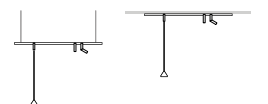
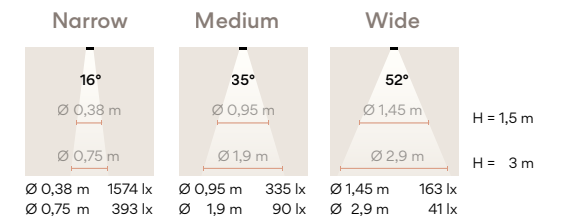
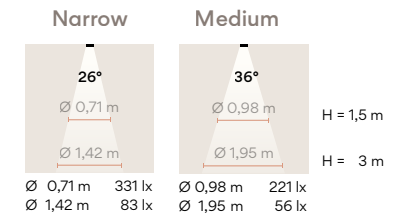

A conductive bar represents the central element from which multiple luminaires can be fixed at any point.

- 11 Black (NCS S 8500-N)
- 24 Beige M1 (NCS S 2005-Y50R)

Electrical connection options



Remote    Built-in    Surface



Pendant Tracks

- A419 120 cm
- A422 210 cm
- A425 300 cm

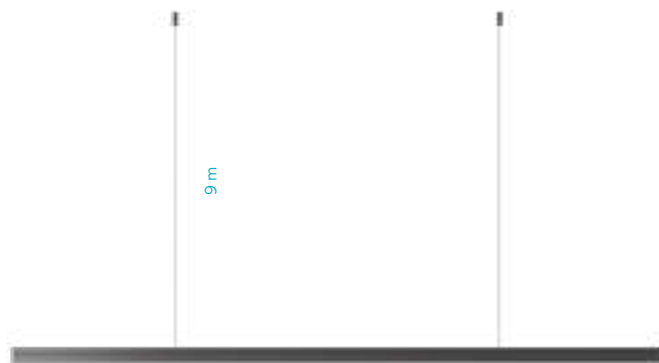

Dynamic light

Dynamic light allows professionals to play with subtle degrees of intensity and colour temperature to recreate a subtle ambience for every scene within a lighting project

Designing an atmosphere of wellbeing is based on two main axes: **space** and **time**. The axis of time implies the concept of dynamic light .

Atmosphere design is intentional, depending on the **design of different scenes according to the specific use of a space** as it evolves throughout the day. Light is dynamic because ambience also depends on **the time of day** and on the influence of the natural light at every moment.



Throughout the day our circadian rhythms respond primarily to light, which regulates our sense of physical and mental wellbeing

Comfortable environments

Vibia's spot accent, downlight and general lighting luminaires include the option of tunable white. Combining these zenithal tunable white lights with the rest of the diffused and indirect lighting effects of Vibia's portfolio, you can design the perfect scene for every moment and use.

Tunable lighting allows for comprehensive temperature regulation and intensity: colour temperature can be precisely tuned depending on the desired atmosphere for every scene.

Static White

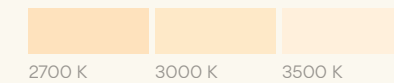

Tunable White

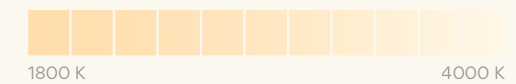

Contact Vibia Support Service at [vibia.com](http://vibia.com) for any kind of assistance or recommendation when designing an atmosphere of wellbeing, or if you require support with control system approach..



Bind track is compatible with the Skan, Slim, North, Tempo and Tube pendant collections, presenting a range of decorative silhouettes with multiple lighting effects. Single or multiple pendants can be suspended as desired, allowing for the formation of intricate chandeliers created from a compilation of tracks with multiple pendants.

Track adapter: Aluminum

**LED Colour Temperature**

2700 K; 3000 K; 3500 K  
CRI>90

**Control**

Analog: On/Off; 1-10V (simultaneous line);  
Digital: DALI-2 (simultaneous line);  
Smart: Casambi (simultaneous line);  
Casambi (P2P); ProtoPixel\* (P2P)

\*ProtoPixel products are compatible with all other DALI-2 products via a designated gateway (please consult us)

Updated detailed spec sheets on [vibia.com](http://vibia.com)



Track adapter

- Black (NCS S 8500-N)
- Beige M1 (NCS S 2005-Y50R)



6560 (Black)  
6561 (Beige)

Skan Colours

- 10 White (NCS S 0300-N)
- 11 Black (NCS S 8500-N)
- 24 Beige M1 (NCS S 2500-Y50R)
- 37 Terra Red (NCS S 4040-Y70R)
- 42 Blue M1 (NCS S 5010-B10G)
- 47 Green L1 (NCS S 4005-G80Y)



6570 (Black)  
6571 (Beige)

Slim Colours

- 10 White (NCS S 0300-N)
- 11 Black (NCS S 8500-N)
- 24 Beige M1 (NCS S 2500-Y50R)
- 37 Terra Red (NCS S 4040-Y70R)
- 47 Green L1 (NCS S 4005-G80Y)
- 68 Ocre (NCS S 3050-Y30R)



6575 (Black)  
6576 (Beige)

North Colours

- 10 White (NCS S 0300-N)
- 11 Black (NCS S 8500-N)
- 24 Beige M1 (NCS S 2500-Y50R)
- 42 Blue M1 (NCS S 5010-B10G)



6590 (Black)  
6591 (Beige)

Tube Colours

- 10 White (NCS S 0300-N)
- 15 Grey L2 (NCS S 2500-N)
- 16 Grey M1 (NCS S 4500-N)
- 21 Black Grey (NCS S 7000-N)
- 24 Beige (NCS S 2500-Y50R)
- 37 Terra Red (NCS S 4040-Y70R)



6580 (Black)  
6581 (Beige)

Tempo Colours

- 18 Graphite (ADAPTA RF9913WX)
- 37 Terra Red (NCS S 4040-Y70R)
- 58 Cream (RAL 7044)
- 62 Green (NCS S 3010-G20Y)



6583 (Black)  
6584 (Beige)

Tempo Colours

- 18 Graphite (ADAPTA RF9913WX)
- 37 Terra Red (NCS S 4040-Y70R)
- 58 Cream (RAL 7044)
- 62 Green (NCS S 3010-G20Y)



6586 (Black)  
6587 (Beige)

Tempo Colours

- 18 Graphite (ADAPTA RF9913WX)
- 37 Terra Red (NCS S 4040-Y70R)
- 58 Cream (RAL 7044)
- 62 Green (NCS S 3010-G20Y)

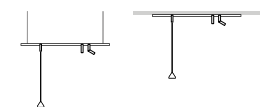

# North



Design by Arik Levy.

North pendant collection consists of triangular Aluminum shades pendant from cables and adjustable carbon fibre rods. The rod and shade are disconnected from one another via nearly invisible cables in a dynamic system of adjustable parts, directing the LED-powered light where needed.



INDIVIDUAL MODEL



5660  
Ø 16 cm



5662  
Ø 40 cm



5664  
Ø 60 cm



5670  
Ø 16 cm



5672  
Ø 40 cm



5674  
Ø 60 cm

- 10 White (NCS S 0300-N)
- 11 Black (NCS S 8500-N)
- 24 Beige M1 (NCS S 2005-Y50R)
- 42 Blue M1 (NCS S 5010-B10G)

Finish customization  
(Available options: Vibia colour palette)

Diffuser: PMMA  
Shade: Aluminum  
Rods: Carbon Fiber  
Canopy: Steel

LED Colour Temperature

- 2700 K; CRI >90
- 3000 K; CRI >80
- 3500 K; CRI >90

Control

Individual model  
Analog: Push; 1-10V  
Digital: DALI-2  
Smart: Casambi

Electrical connection options



Remote Built-in Surface Free Wire

BIND related product

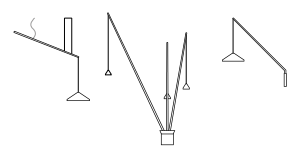

Pg 264/412 VOL 1 Pg 330 VOL 2

MULTIPLE MODELS

Set your composition at [vibia.com](http://vibia.com)



Plusminus

# Plusminus

Visual Hierarchy  
284

Raining Light  
294

Flowing Pendants  
300

Creative Canopy Connection  
310

Defying Gravity  
316

Suspended Animation  
324

Reimagining Spaces  
332

Framing Space  
338

# Plusminus<sup>+ -</sup>

Design by Diez Office

Plusminus is a versatile lighting system that takes the concept of the light rail to a new level. The conductive textile ribbon at its core allows for free placement of the luminaires and the creation of unique light solutions on the spot.





The fluidity  
of light



Equal parts easy and avant-garde, Plusminus harnesses the design of a belt in a groundbreaking lighting concept that merges materiality and light. Featuring a textural, fabric belt that conducts electricity, it enables light to flow through space. Plusminus provides professionals a powerful toolkit for creating personalised lighting effects and unique atmospheres with different luminaires via Vibia's digital platform and click-and-connect functionality.



## Luminaire types and lighting effects



### Sphere

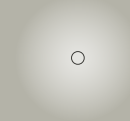

#### **Volumetric Diffuser**

distributes light equally in all directions (360°). It attracts a relaxed gaze towards the point of light, and creates a calm, very comfortable atmosphere. The light sphere bathes all surfaces of the space, producing a peaceful, richer and extremely homogenous ambience.



### Semisphere



#### **Hidden Diffuser**

emits a soft light that generates low contrasts between the illuminated areas and the shadows cast. The opaque part of the shade helps to direct the light through the diffuser, providing illumination that is both peaceful and concentrated at the same time.



### Cone



#### **Hidden Diffuser**

emits a soft light that generates low contrasts between the illuminated areas and the shadows cast. The opaque part of the shade helps to direct the light through the diffuser, providing illumination that is both peaceful and concentrated at the same time.

### Spotlight



#### **Flat Diffuser**

emits a soft light that generates low contrasts between the illuminated areas and the shadows cast. It is ideal for reading situations or when the light output is visible, as it does not produce glare.



#### **Accent**

emphasizes objects or architectural elements with intensive cones of light. Luminance contrasts attract the eye and bring the illuminated objects into the foreground. The light output is directed towards the object or architectural element and not towards the person, in order to avoid glare.



### Linear Diffuser



#### **Linear Flat Diffuser**

provides a high degree of uniformity on the horizontal plane and generates a first layer of illumination on which to add more specific lighting applications. It generates soft shadows and subdued brightness in which the space and its component elements do not display visual hierarchies.



### Linear Low UGR



#### **Linear High Efficiency Low Glare**

offers medium brightness and clarity of forms. Direct illumination, extended beam and luminaire performance enable installations with high-energy efficiencies and low-glare levels below UGR<19.

#### **Linear High Comfort Low Glare**

provides high levels of illumination and comfort with UGR levels below 19. It is also ideal for work or meeting areas.





Easy connection  
Fix / Click / Connect

Each belt, which can be cut as needed, accommodates multiple luminaires and operates with simple plug-in technology for unparalleled ease of installation and connection. The belt offers adjustments in tension from taut to relaxed as well as click-and-connect functionality, snapping into a buckle attached to each luminaire.



## Shaping Atmospheres

Endlessly versatile, Plusminus offers the freedom to combine different levels of diffuse and focused illumination as never before to create a unique atmosphere in any interior.

Design a space by drawing with the belt, conducting light to the right place while evoking an emotional response and sense of wellbeing.

Visual Hierarchy  
Raining Light  
Reimagining Spaces  
Framing Space  
Defying Gravity  
Flowing Pendants  
Creative Canopy Connection  
Suspended Animation

## Visual Hierarchy

Plusminus's revolutionary belt design provides a powerful toolkit for reimagining spaces. Combining multiple lighting effects and placing light precisely where needed, it creates visual hierarchies in any space.

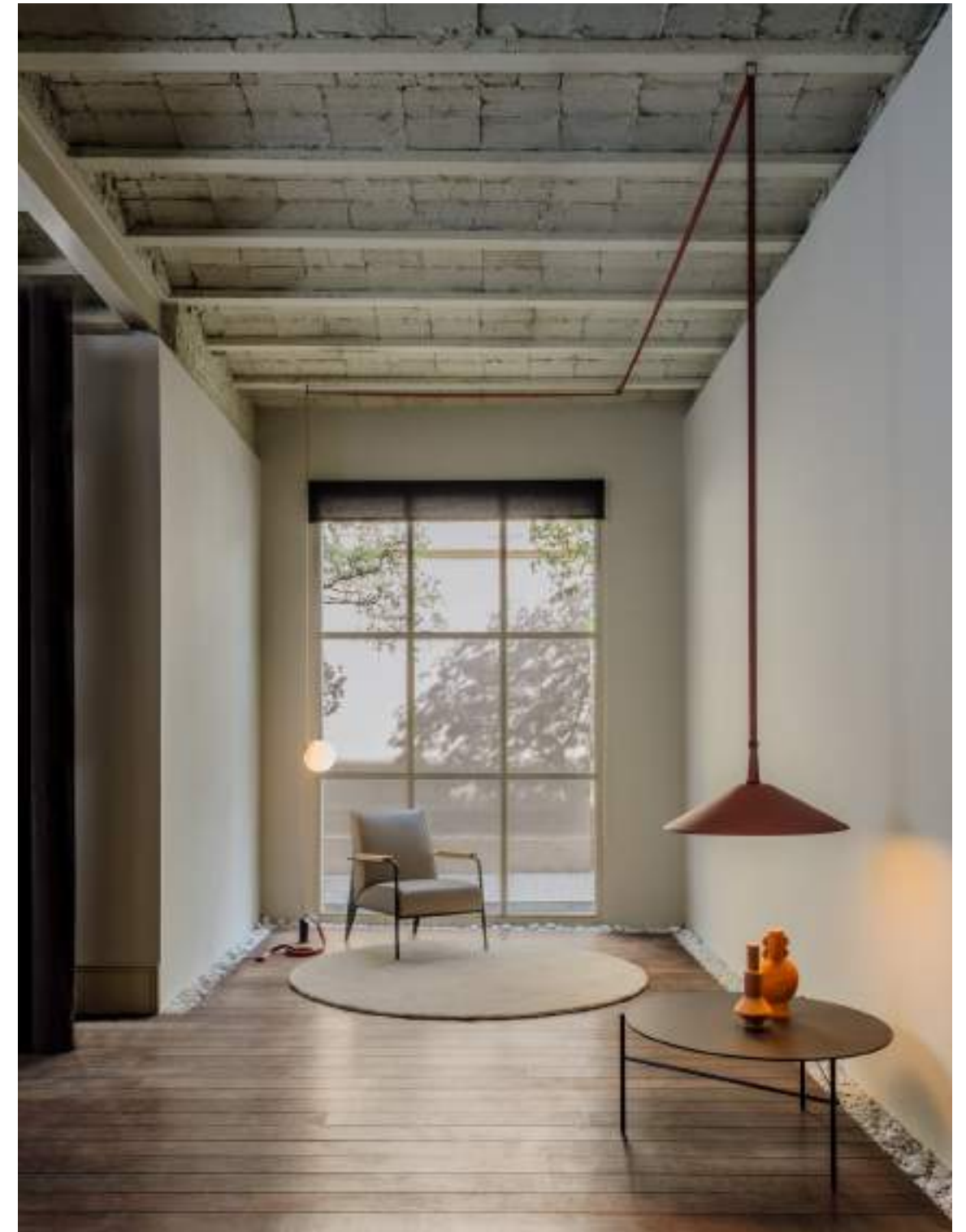



The fabric belt offers endless flexibility of use, conducting light across a range of ceiling shapes and angles.

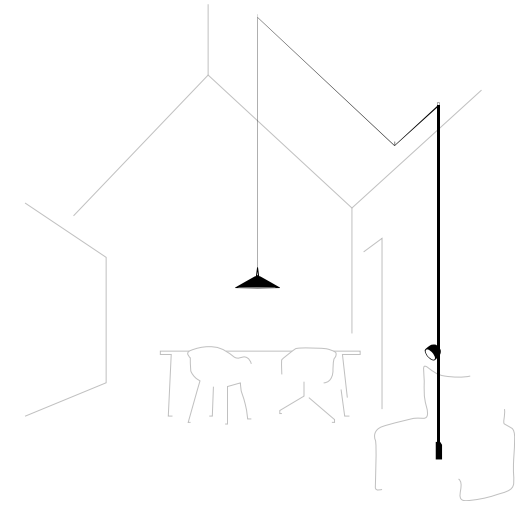





Place multiple lights in different positions throughout a space with just a single electrical connection.

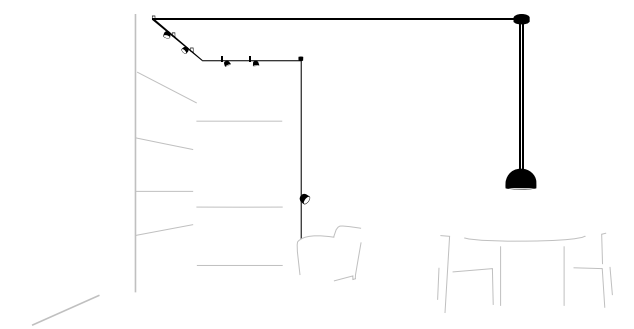



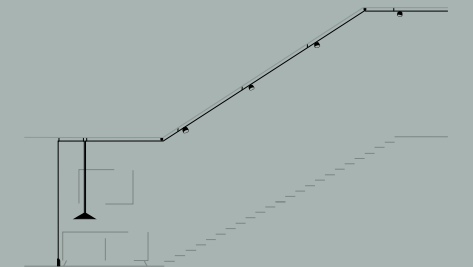
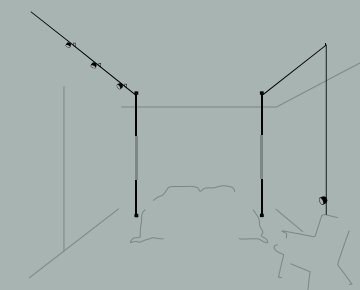
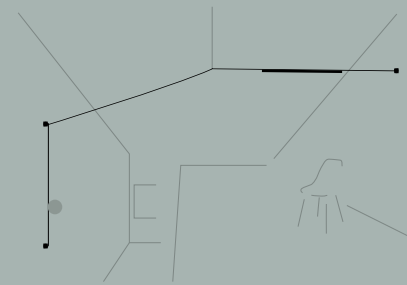
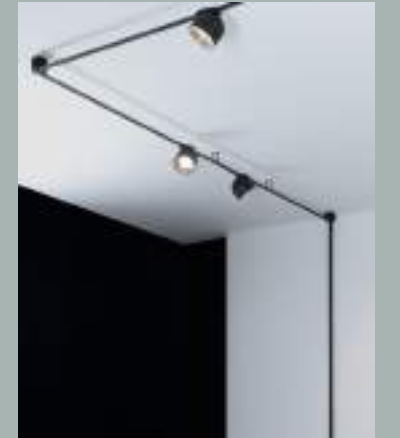

An invitation to position light without limits, Plusminus accommodates any kind of architecture—no matter how unique.

## Raining Light

From a single spotlight positioned close at hand to a cascading installation of luminaires overhead, Plusminus's ceiling-to-floor possibilities create a stunning display of light in varying intensity and effect.



Plusminus's powerful design capabilities include constructing columns of light up to 60 meters high.





### Climbing the Walls

An innovative take on the wall lamp, Plusminus's fabric belt forms a linear architecture that hosts an array of lighting options—from a long row of accent lamps illuminating a hallway to sleek luminaires straddling opposite walls.



## Flowing Pendants

Defined by their flowing, continuous forms, Plusminus pendants provide endless possibilities for illuminating a space. Suspended overhead in silhouettes, soft and draped or taut and precise, their graphic presence creates distinctive ambiances.





“The Plusminus collection is a toolbox which, thanks to the wide range it contains, enables you to find solutions to an incredible number of lighting problems. I think architects and lighting designers today need investment certainty, and Plusminus offers that.”

Stefan Diez

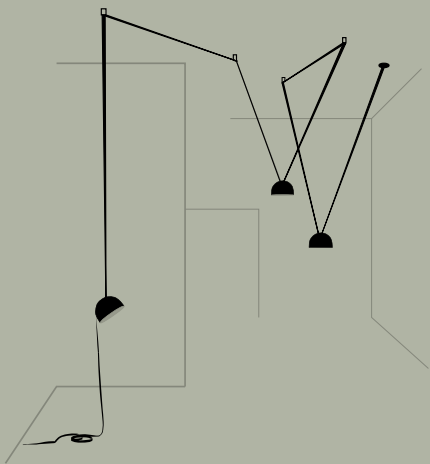

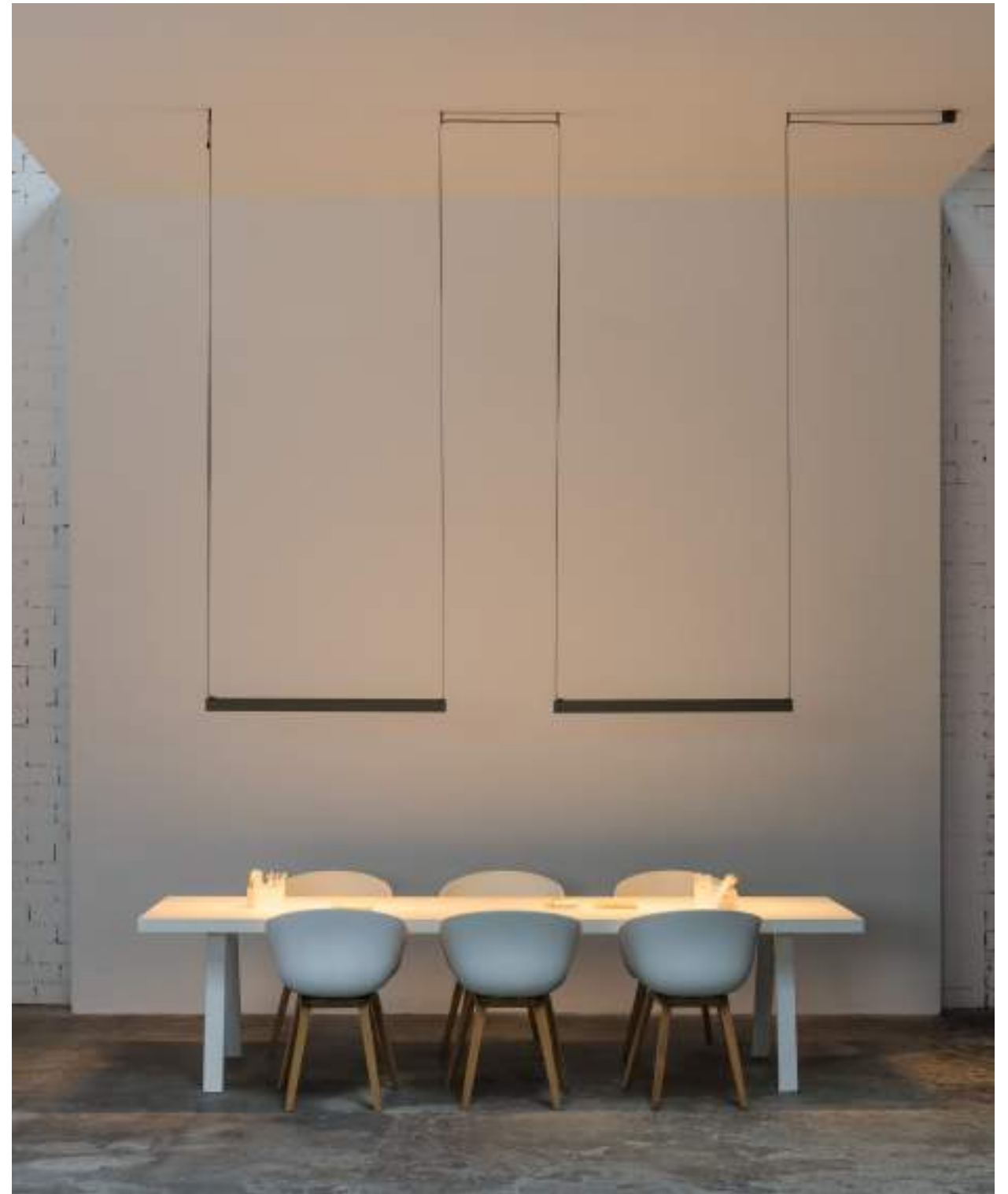
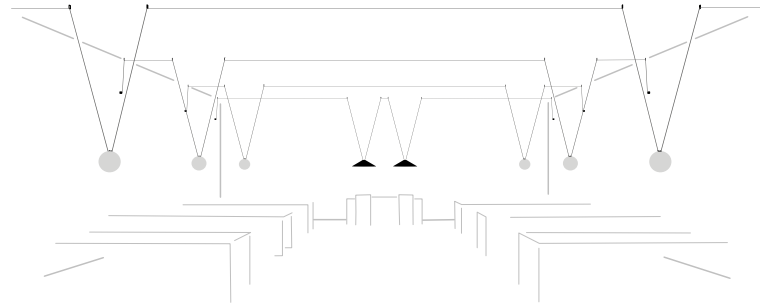

### Composing Light

Both object of beauty and high-performance lighting toolkit, Plusminus offers personalised atmospheres while doubling as striking visual sculpture.





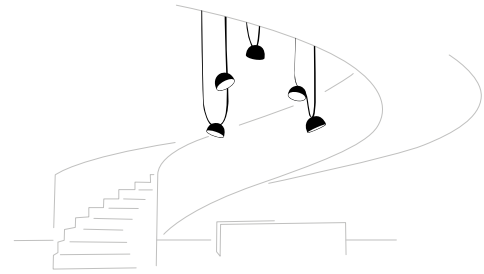

## Creative Canopy Connection

Plusminus reimagines the use of the canopy. The belt flows in and out of the canopy, establishing conductivity and electrical connection where needed, with creative configurations becoming an essential element of the design.







A surface canopy presents yet another opportunity to play with Plusminus, securing the belt in one spot while allowing it to flow freely across a space in countless configurations.

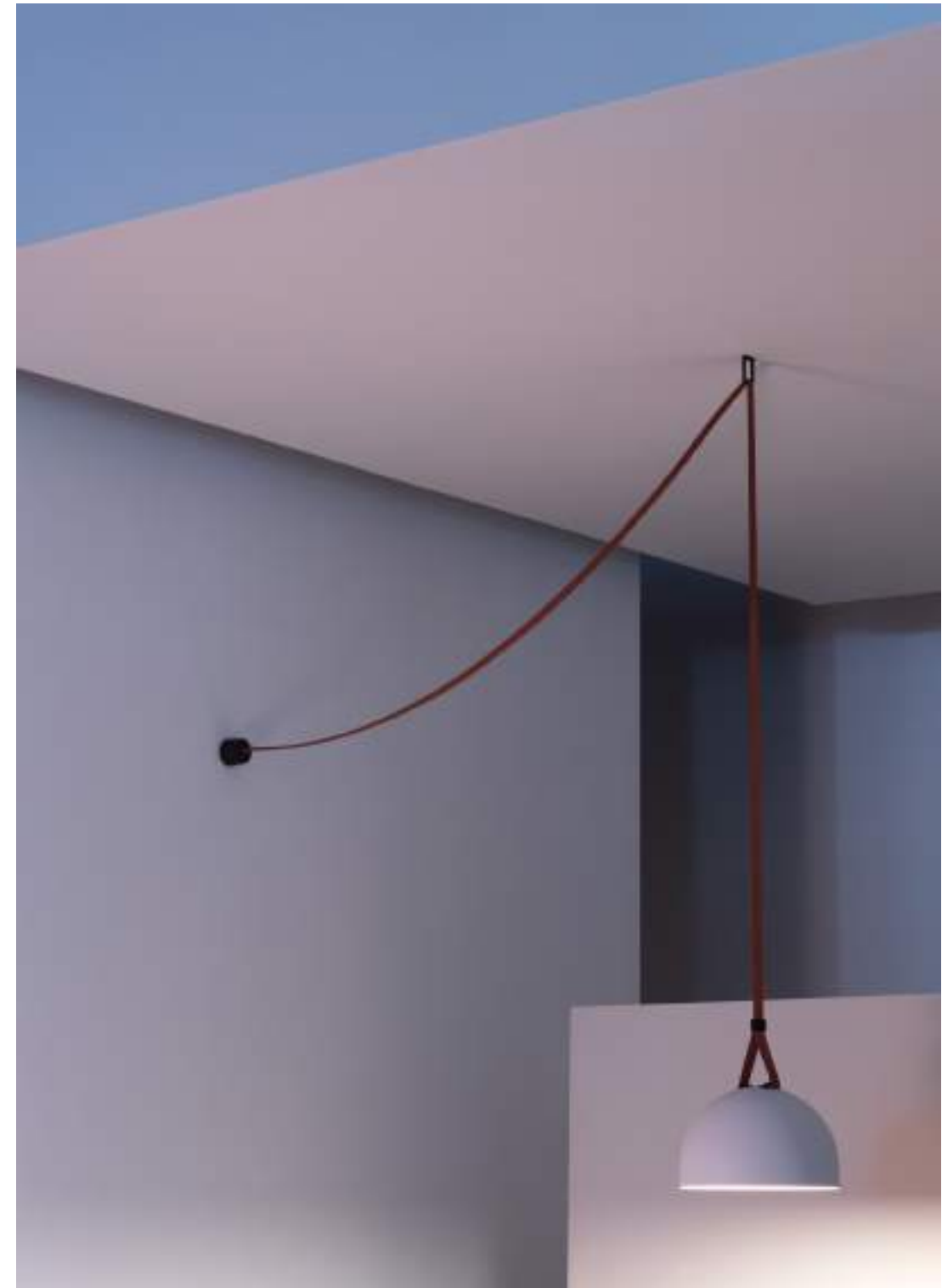

## Defying Gravity

Plusminus's nearly invisible tensor wire introduces an element of intrigue to lighting. The wire extends from the belt to the wall or the ceiling, quietly completing the luminaire's design while lending it the magical look of floating in midair in defiance of gravity.





### Balancing Act

Wall-to-wall installations hang in a delicate balance with Plusminus's invisible ceiling tensor. Lifting or lowering the belt, the cable creates varying degrees of tension that enables infinite configurations.

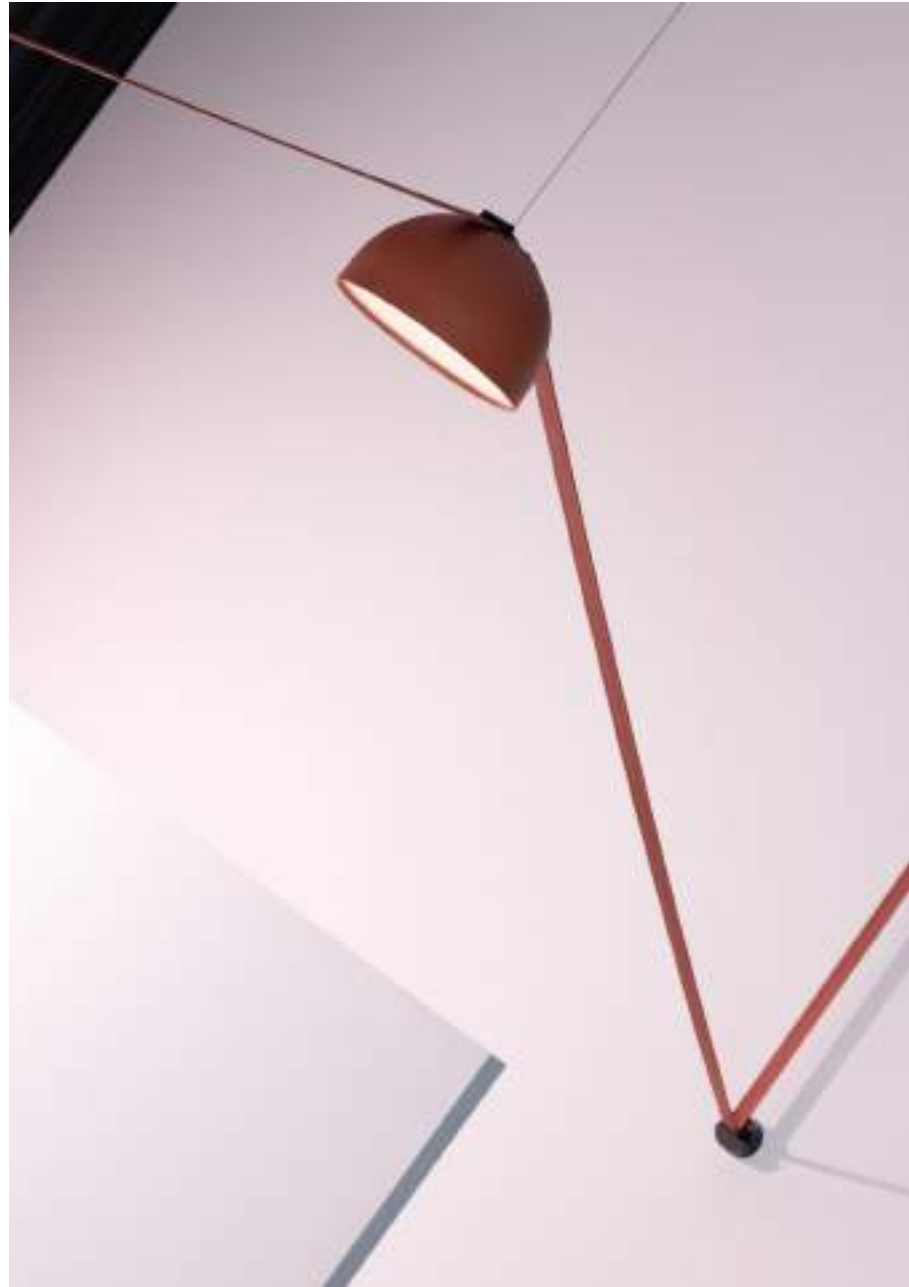





## Suspended Animation

Ceiling design no longer limits lighting options thanks to Plusminus. A bar suspended from the ceiling serves as both a sleek architectural feature and an opportunity for creative exploration.



Play with height and length to suit any setting and affix personalised belt designs for a one-of-a-kind look.



Bar length 2 m  
Tensor cables max. 5 m

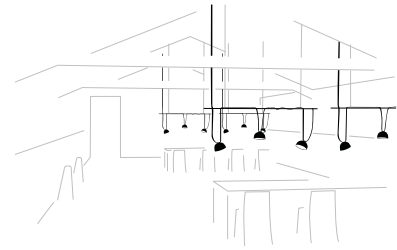





## Reimagining Spaces

Merging light and materiality, Plusminus introduces masterful new ways to delineate space. Tracing a slender outline, the fabric belt creates a contained area within an open layout, serving as an illuminated perimeter with minimal presence.





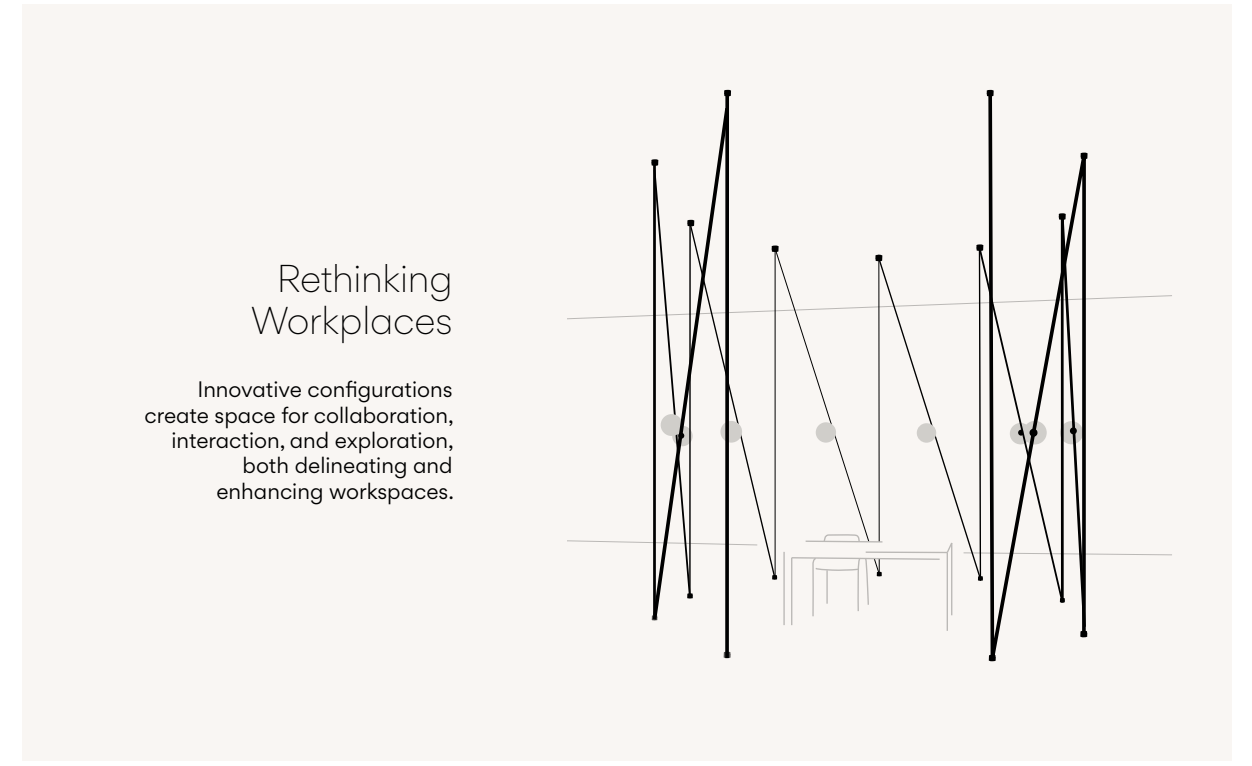
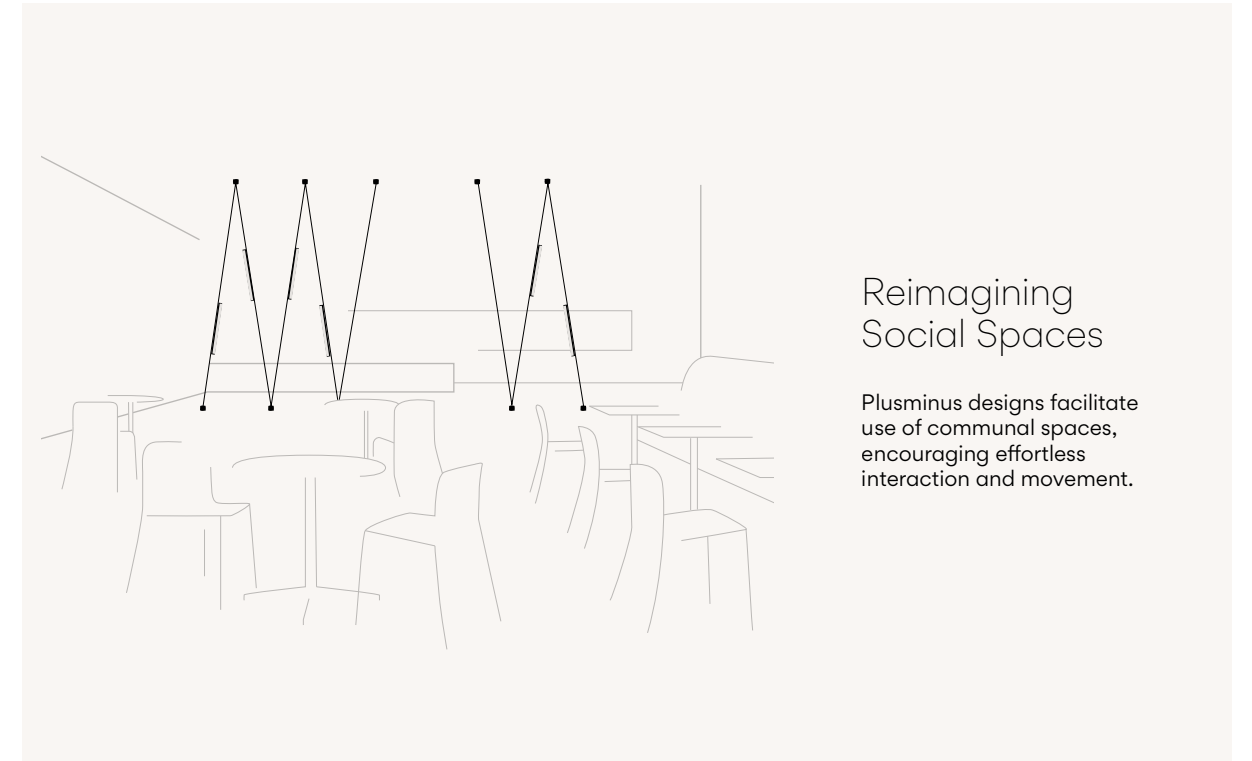

## Framing Space

Plusminus's lean lines define an interior with precise transverse trajectories. Stretching from wall to wall, the belt evokes the effect of a false ceiling, reducing a room's volume and bringing light closer. With kinetic crisscrossed and zigzagged configurations or soothing straight lines, the luminaires appear integrated into the architecture.

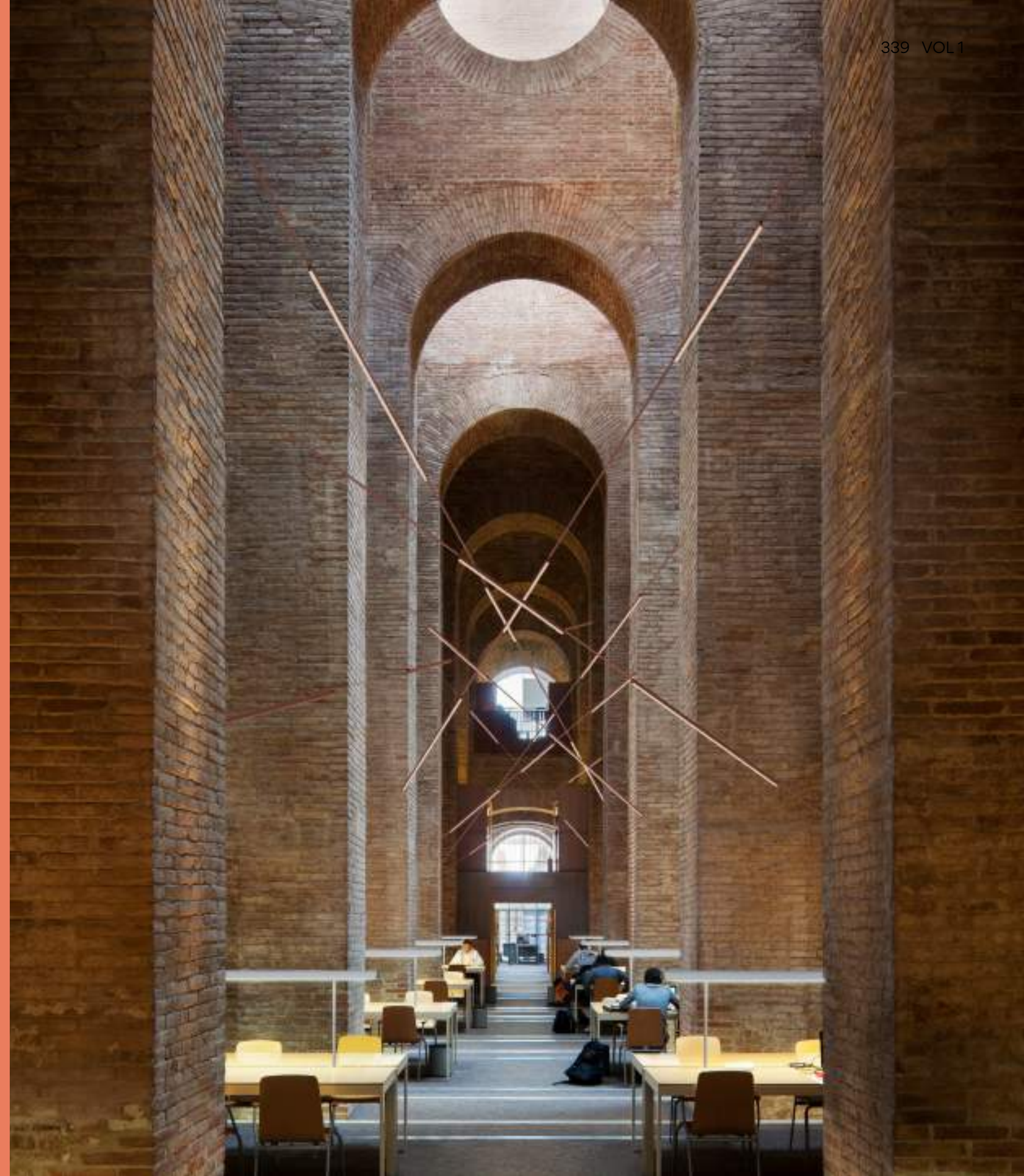



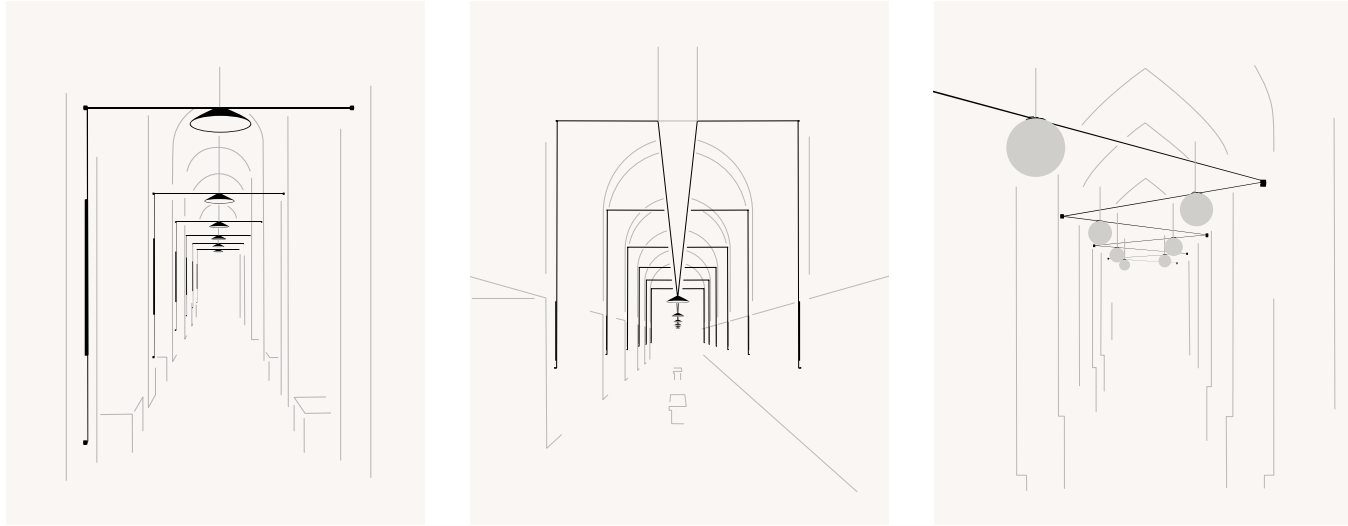

Plusminus's nearly invisible tensor wire introduces an element of intrigue to lighting. Lifting or lowering the belt, the cable creates varying degrees of tension that enables infinite configurations.



Plusminus' inherent adaptability provides the perfect solution for spaces that feature special architecture, scale, materials, or artwork.

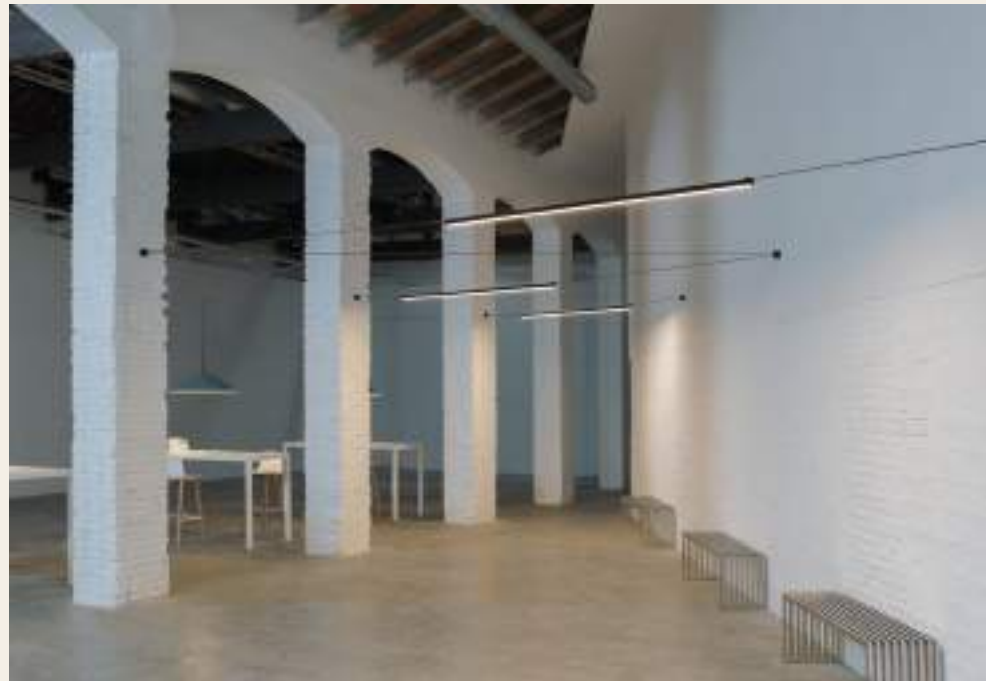

Belt

- Black
- Terra Red
- Blue
- Green
- Beige

Maximum 60 meters length  
per electrical connection point

Fire Hazard Testing.  
GW-960. fulfills the requirements of:  
standards EN 60695-2-10:2013;  
EN 60695-2-11:2015;  
EN 60695-2-12:2011 / A1:2014

Belt: Polyester

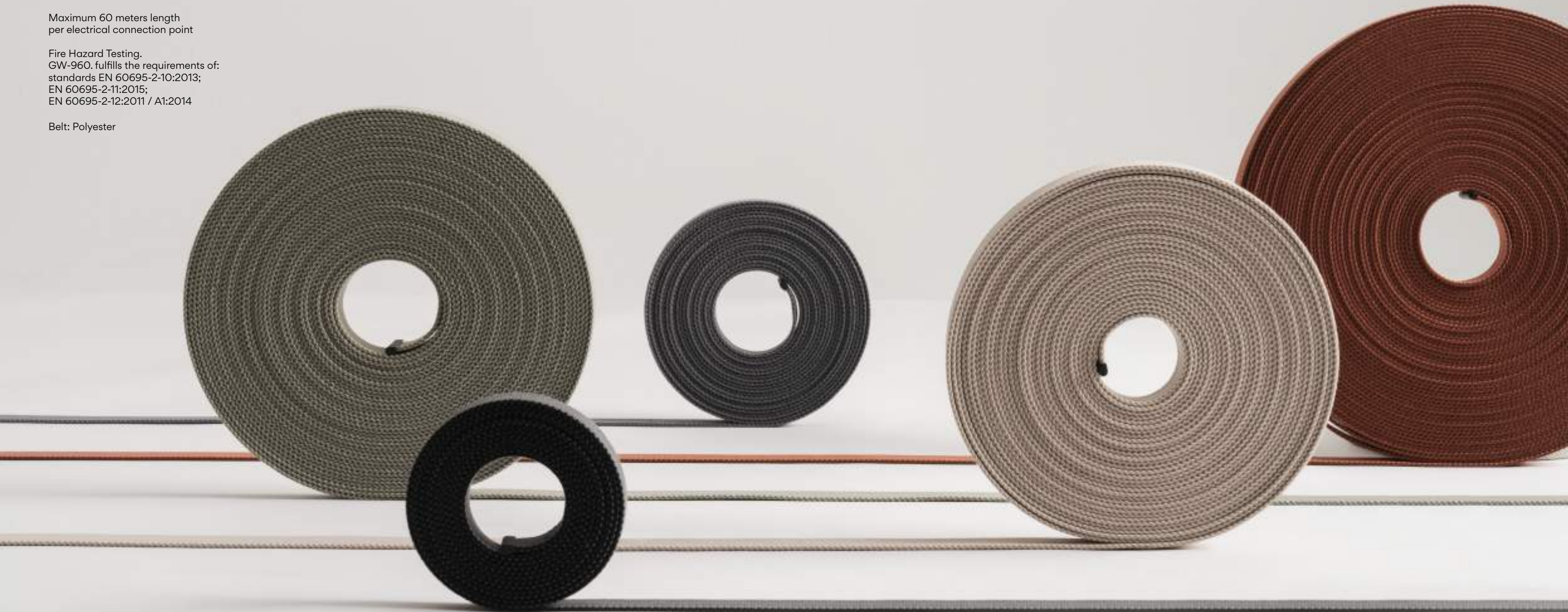

## Luminaires types

- 11 Black (NCS S 8500-N)
- 24 Beige M1 (NCS S 2005-Y50R)
- 37 Terra Red (NCS S 4040-Y70R)
- 42 Blue M1 (NCS S 5010-B10G)
- 53 Green M1 (NCS S 6005-G80Y)

**LED Colour Temperature**  
 LED 2700 K; 3000 K; 3500 K  
**Accent**  
 2700 K - 941 lm  
 3000 K - 987 lm  
 3500 K - 1022 lm  
 7,9W  
 CRI>90

**Control**  
 Analog: On/ Off; 1-10V; Push  
 Digital: DALI  
 Smart: Casambi; Casambi integrated on each individual luminaire (P2P); ProtoPixel Simultaneous\*; ProtoPixel integrated on each individual luminaire (P2P)\*  
 \*ProtoPixel products are compatible with all other DALI-2 products via a designated gateway (please consult us)

### Sphere



**6230**  
Ø 20 cm

**6235**  
Ø 30 cm

### Semisphere



**6220**  
Ø 20 cm

**6225**  
Ø 30 cm

### Cone



**6240**  
Ø 60 cm

**6245**  
Ø 80 cm

### Spotlight



**Accent**  
**6200 Narrow**  
Ø 10 cm

**Accent**  
**6205 Medium**  
**6210 Wide**  
Ø 10 cm

**Flat diffuser**  
**6215**  
Ø 10 cm

#### Spotlight - Accent

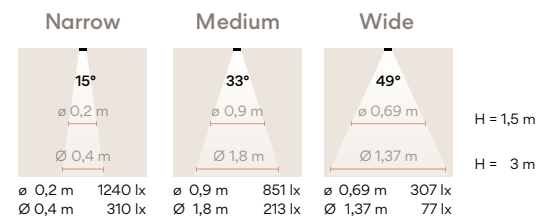

Updated detailed spec sheets on [vibia.com](http://vibia.com)

### Linear Diffuser



**6250**  
102 x 4 x 3 cm

**6255**  
202 x 4 x 3 cm

### Linear High Comfort Low Glare



**6260**  
26,8 x 7 x 3 cm

**6265**  
52,5 x 7 x 3 cm

**6270**  
103,7 x 7 x 3 cm

### Linear High Efficiency Low Glare



**6275**  
26,8 x 7 x 3 cm

**6280**  
52,5 x 7 x 3 cm

**6285**  
103,7 x 7 x 3 cm

## Electrical connection options

Choose your preferred installation option according to your needs.

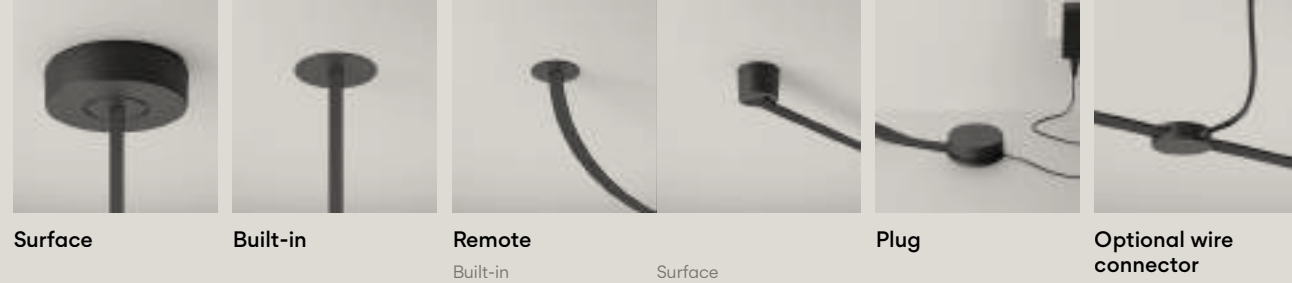

## Dimming control options

Choose your preferred installation option according to your needs.

| Dimming Control  | Electrical Connection |                        |                      |                 |
|--|-----------------------|------------------------|----------------------|-----------------|
|  | Surface<br>25 - 240 W | Built-in<br>25 - 240 W | Remote<br>25 - 240 W | Plug<br>Max 60W |
| On/ Off  | ✓                     | ✓                      | ✓                    | ✓               |
| Push Switch  | —                     | —                      | —                    | ✓               |
| Push Simultaneous  | ✓                     | ✓                      | ✓                    | —               |
| 1-10V Simultaneous                                       | ✓                     | ✓                      | ✓                    | —               |
| DALI Simultaneous  | ✓                     | ✓                      | ✓                    | —               |
| Casambi Simultaneous                                     | ✓                     | ✓                      | ✓                    | ✓               |
| Casambi integrated on each individual luminaire (P2P)    | ✓                     | ✓                      | ✓                    | ✓               |
| ProtoPixel Simultaneous                                  | ✓                     | ✓                      | ✓                    | ✓               |
| ProtoPixel integrated on each individual luminaire (P2P) | ✓                     | ✓                      | ✓                    | ✓               |

## Belt Options Surface Canopy

Choose your preferred installation option according to your needs.



## Belt terminations

Belt terminations can be adjusted during the installation process according to your preference.



## Easy to design and install

Compose a personalised Plusminus  
at [vibia.com](http://vibia.com)

### From scratch



- + Create and compose projects in detail.
- + Draw and personalise in 3D to see it in space.
- + Or personalise it step by step without drawing.

### From of a layout

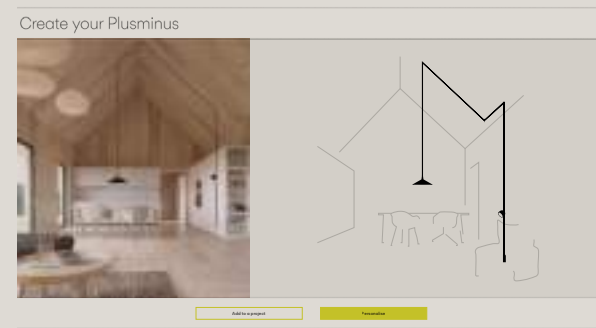

- + Personalise and adapt it to the needs of your project.
- + Add it to your project and edit it at any time.
- + More than 100 creations for you.

## Accessories Toolbox

Thought out to the smallest detail.  
Receive your personalised accessories toolbox  
for a quick and easy installation.



352 VOL1

PLUSMINUS

353 VOL1



Floor & Table



# Floor & Table

Africa  
356

Balance  
400

Dama  
364

Flat  
405

Ghost  
438

I.Cono  
424

Jazz  
444

Knit  
378

Lily  
372

Mayfair  
394

Mayfair  
Mini  
388

Musa  
454

North  
412

Offset  
460

Out  
468

Pin  
418

Plusminus  
Solo  
472

Skat  
434

Sticks  
Solo  
384

Suite  
430

Warm  
448

# Africa



Design by Francisco Gomez Paz.

An object of desire, Africa is a unique gift that combines richness of form and materiality with high performance lighting capabilities. A holistic exploration of beauty and functionality.





“Africa was born as a response to new nomadic, free and casual ways of inhabiting, in which residential and professional spaces are increasingly hybridised”.

Francisco Gomez Paz



Portable

Its chargeable LED light source provides three levels of intensity which are controlled by a simple push button at the head.

Bolt-down

The bolted version is fixed in position, designed to integrate within the surrounding architecture.



Battery capacity  
10.000mAh

Battery voltage  
3,7V

Battery autonomy:  
6,5h at 100% Intensity  
10h at 66% Intensity  
20h at 33% Intensity

1<sup>st</sup> Pulse  
Intensity 33%

2<sup>nd</sup> Pulse  
Intensity 66%

3<sup>rd</sup> Pulse  
Intensity 100%





**5580**      **5585**  
 Ø 5 x 45 cm      Ø 5 x 40 cm

Portable



**5590 Bolt-down**      **5595 Bolt-down**  
 Ø 5 x 45 cm      Ø 5 x 40 cm

Bolt-down

- 24 Beige M1 (NCS S 2005-Y50R)
- 25 Beige D1 (NCS S 4005-Y50R)
- 29 Brown D1 (NCS S 8005-Y50R)
- 38 Terra Dark (NCS S 5040-Y70R)
- 83 Walnut (Tray)

Body: Aluminum  
 Diffuser: PC- Polycarbonate  
 Tray: Wood (Rustic Walnut)

**LED Colour Temperature**  
 2700 K  
 CRI>90

**Control**  
 Analog: Push



**A439**

Ø 27 cm



**A440**

Ø 27 cm

Tray that allows three or two luminaires to be charged by contact

To recharge the luminaire, the shaft slides seamlessly into a magnetised charger, a flawless continuation of its sculptural expression.



# Dama



Design by Ludovica+Roberto Palomba.

A homage to the Abat-Jour lamp, the Dama collection connects the charm of tradition with the finesse of contemporary lighting design. Combining technical precision with aesthetic simplicity, Dama is ideal for shaping an intimate atmosphere with an elevated look.



Distinguished by its exposed frame, a cylindrical shade rests neatly on top of a slender aluminium stem which branches out into three legs available in two stylish finishes. The delicacy of the frame provides a feeling of weightlessness, enhanced by the softness of the paper diffuser.





“Paper, with its ‘imperfect perfection’, gave us precisely the sense of warmth that we were looking for, and at the same time a sense of lightness”.

Ludovica+Roberto Palomba





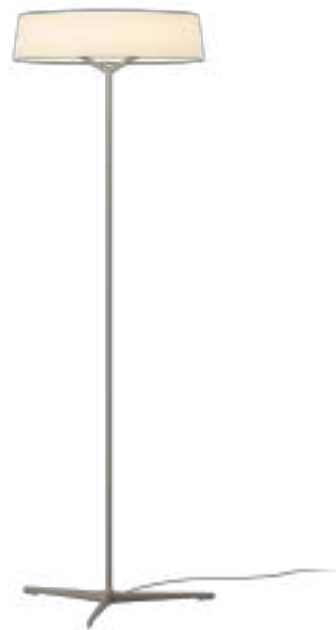

**3230**  
Ø 49,5 x 140 cm



**3225**  
63,5 x 61 cm

- 11 Black (NCS S 8500-N)
- 25 Beige D1 (NCS S 4005-Y50R)

Tube: Steel  
Base: Zinc Alloy  
Shade: Paper

**LED Colour Temperature**  
2700 K  
CRI>90

**Control**  
Analog: Push  
Smart: Casambi; ProtoPixel\*  
\*ProtoPixel products are compatible with all other DALI-2 products via a designated gateway (please consult us)

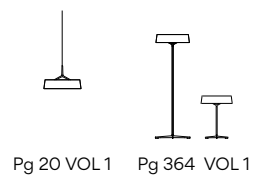

With a desire for integrity, Dama incorporates a circular LED with an internal diffuser, projecting a warm 360 degree glow from an invisible source.



Floor switch



Table switch



# Lily



Design by Ludovica+Roberto Palomba.

The Lily collection reveals contemporary lines with an ineffable lightness. Its graceful glass diffuser radiates with warmth and wellbeing, ideal for an elegant interior with a relaxed ambience.







Pairing timeless design with an ambient 360 degree glow, Lily is as intimate in performance as it is elegant in form.

A contemporary reimagining of the classic lampshade, it is characterised by a smooth, translucent glass diffuser which gently curves over at the top to conceal an invisible LED light source. A elegant aluminium stem denotes appeal as well as stability. The base consists of three or four rods which meet in the centre before branching out at the top to support the diffuser. The slender nature of the stem accentuates the sensuous curve of the diffuser.

- 11 Black (NCS S 8500-N)
- 25 Beige D1 (NCS S 4005-Y50R)

Body: Steel  
Shade: Triple opal blown glass

#### LED Colour Temperature

2700 K  
CRI>90

#### Control

Analog: Push  
Smart: Casambi; ProtoPixel\*

\*ProtoPixel products are compatible with all other DALI-2 products via a designated gateway (please consult us)



5720

Ø 49 x 63,5 cm



5725

Ø 49 x 155 cm



Floor switch



Table switch



# Knit



Design by Meike Harde.

Light, materiality and tangibility collide with the Knit collection. Its texture is magnetic, calling out for us to touch its surface, to feel its warmth and to keep it close. Light seeps outwards through the fabric transmitting a soft 360° glow.





KNIT

A single knitted lycra sleeve stretched over an ovoid polymer diffuser, its texture is magnetic, calling out for us to touch its surface, to feel its warmth and to keep it close.

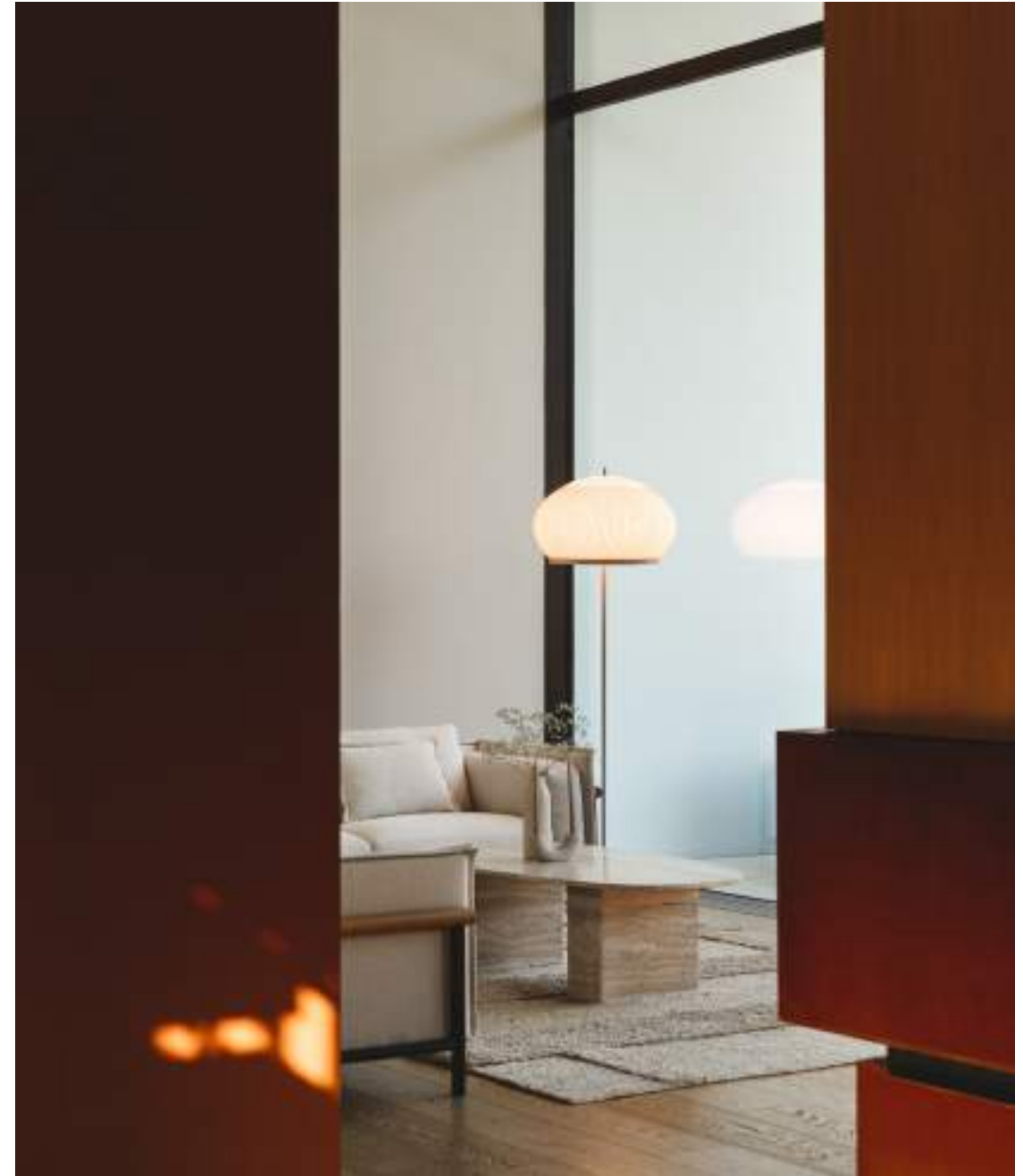



**7480**  
Ø 45 x 178 cm



**7485**  
Ø 45 x 170 cm



**7487**  
Ø 65 x 195 cm



**7490**  
Ø 45 x 55 cm



**7492**  
Ø 65 x 51 cm



**7494**  
Ø 65 x 62 cm

● 24 Beige M1 (NCS S 2005-Y50R)

Fabric shade: PES FR  
Interior diffuser: PE- Polyethylene  
Botom diffuser: PC- Polycarbonate  
Diffuser ring and support: ABS  
Stem: Iron  
Floor base: Zinc Alloy

**LED Colour Temperature**

2700 K  
CRI>90

**Control**

Analog: Push  
Smart: Casambi;  
ProtoPixel\*

\*ProtoPixel products are compatible with all other DALI-2 products via a designated gateway (please consult us)



Floor switch Ref.  
7480, 7485, 7487



# Sticks Solo



Design by Arik Levy.

Sticks Solo floor can be free-standing or arranged floor to wall, connecting two planes of the same space. The stand alone model features one or two Sticks that produce a pleasant ambient lighting effect or indirect light depending on rod rotation.





● 11 Black (NCS S 8500-N)

Stick: Aluminum  
Diffuser: PC- Polycarbonate

**LED Colour Temperature**  
2700 K; 3000 K; 3500 K  
CRI>90

**Control**  
Analog: Push



Floor base & plug



Linear flat diffuser



High energy efficiency and low glare levels UGR<19 for horizontal application Ref. 7376, 7379

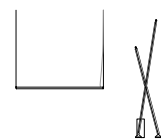

Pg 74/384 VOL 1

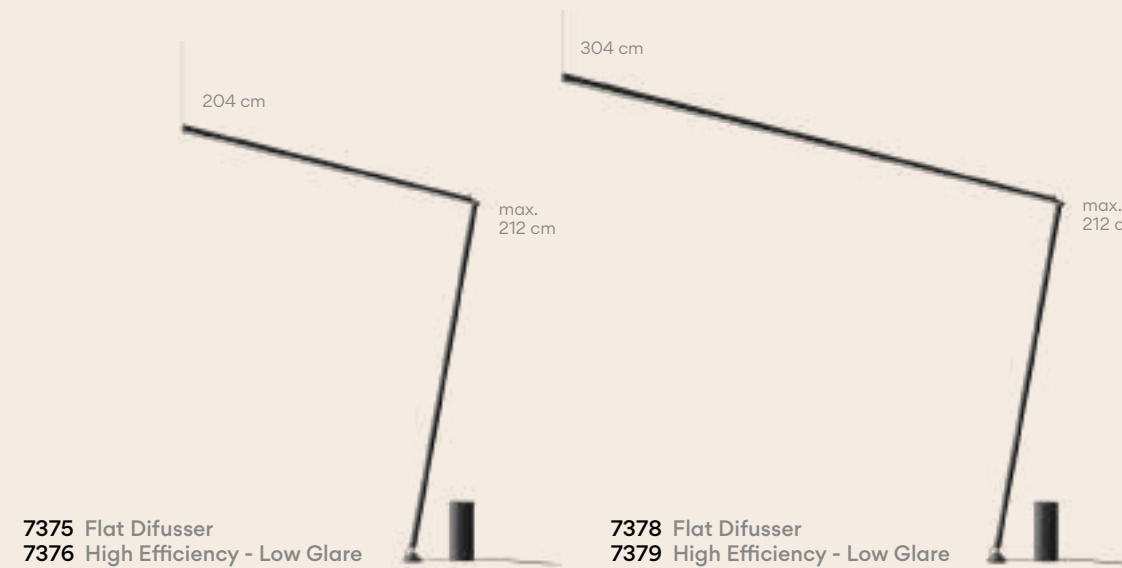
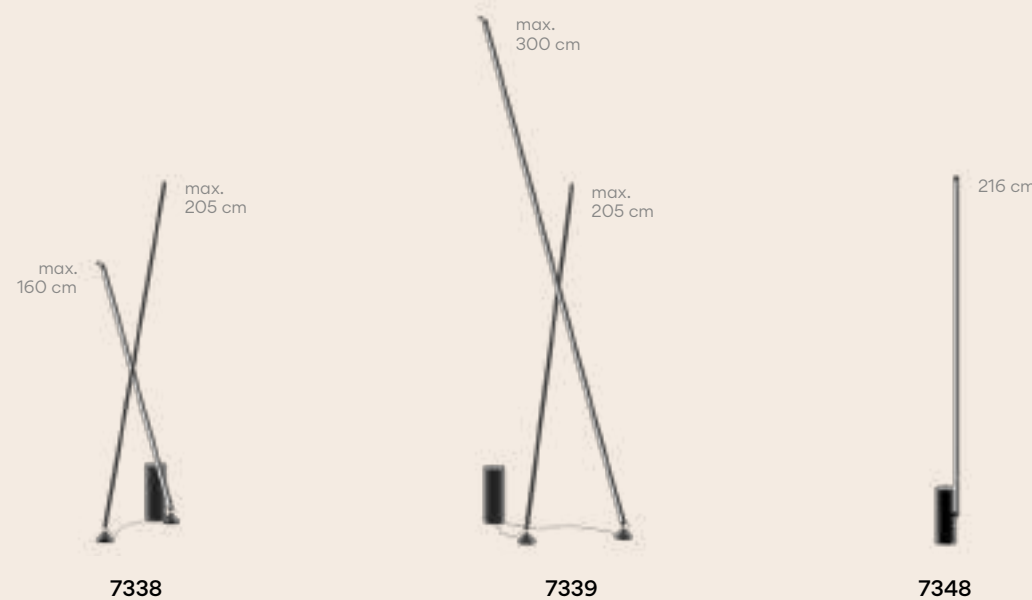

# Mayfair Mini



Design by Diego Fortunato.

The perfect lighting companion, the Mayfair Mini is a small-scale design that casts a contained pool of diffuse, downlight for an intimate atmosphere. A light to grab and go that can be moved where needed -indoors or out- via its slender stem.



The Mayfair Mini is offered in three formats. The portable version is perfect for indoor and outdoor use. Powered by a rechargeable battery, it can be transported to any desired position. It also comes in two bolted versions, available either with a base. The bolted formats are fixed in position, designed to integrate within the surrounding architecture.





5495

Ø 20 x 38 cm

Portable



5496

Ø 20 x 38 cm

Bolt-down



5497

Ø 20 x 38 cm

- 23 Warm White (NCS S 0502-Y50R)
- 25 Beige D1 (NCS S 4005-Y50R)
- 38 Terra Dark (NCS S 5040-Y70R)
- 47 Green L1 (NCS S 4005-G80Y)

Base and shade: ABS + PC- Polycarbonate  
 Diffuser: PC- Polycarbonate  
 Stem: Stainless steel

**LED Colour Temperature**

2700 K  
 CRI>90

**Control**

Analog: On/ Off; Sensor; 1-10V  
 Digital: DALI-2

Ref. 5495

Rechargeable battery autonomy:  
 6h at 100% Intensity  
 12h at 50% Intensity  
 18h at 25% Intensity

Touch sensor 5495 and 5496



Rechargeable battery 5495

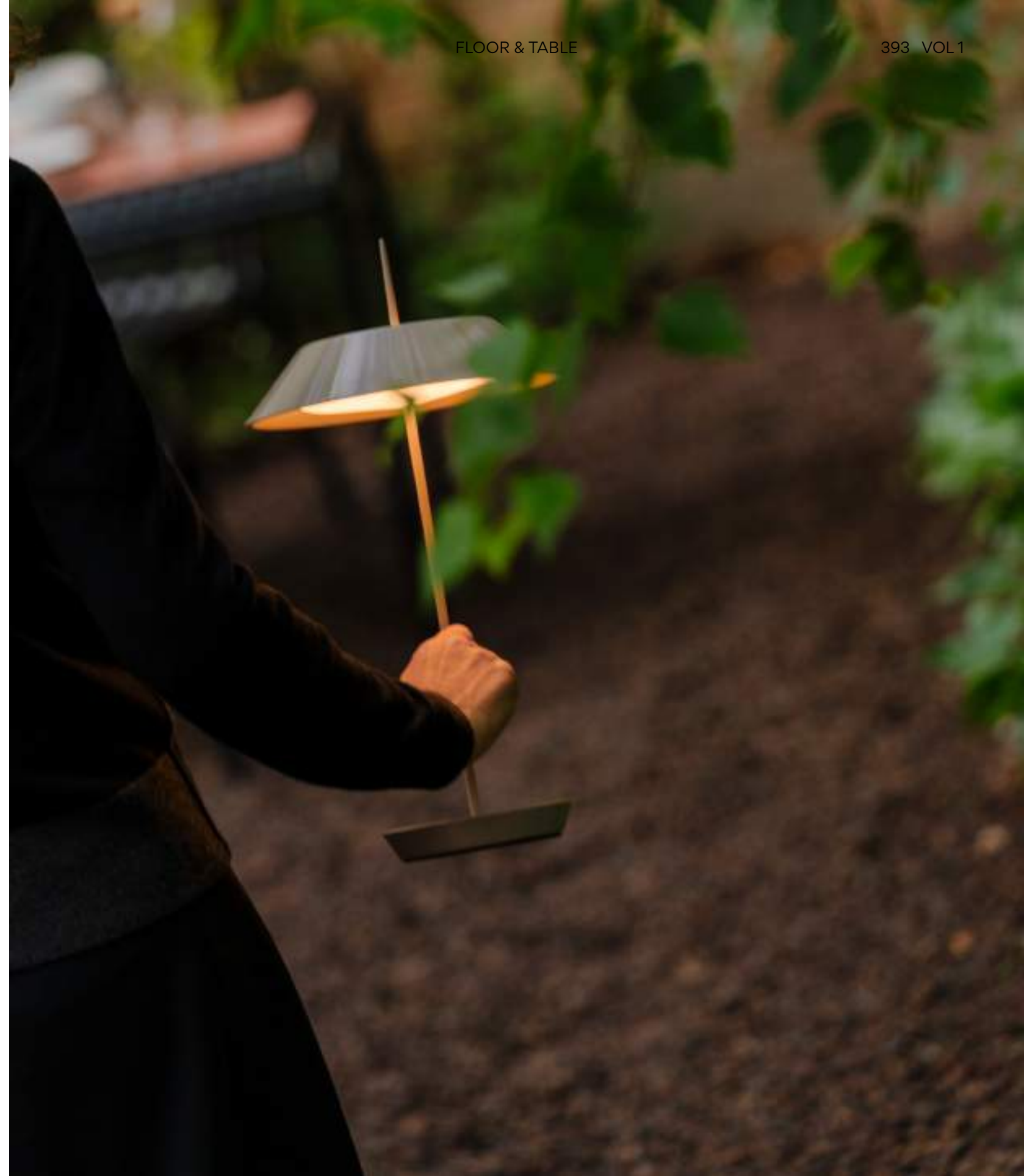

# Mayfair



Design by Diego Fortunato.

A modern reimagining of the traditional 19th-century bouillotte lamp, the Mayfair collection is a statement in contemporary design. Perfectly proportioned, its luminaire casts a pool of diffuse, downward light to create an intimate lighting effect.





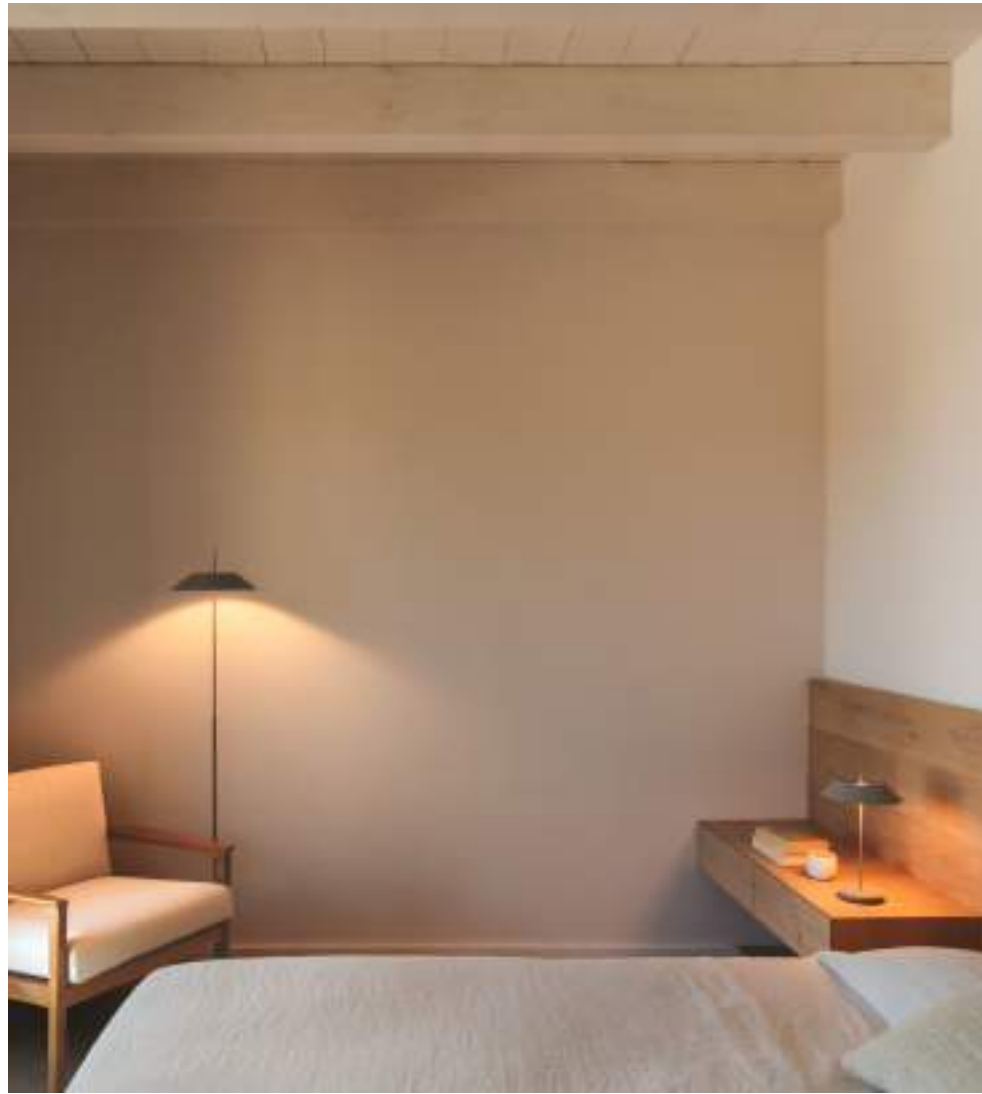

Featuring a steel column and steel or methacrylate shade, the LED-powered floor lamp casts an ambient glow that's ideal for a relaxed interior setting and can be dimmed via an optical sensor.



**5510**  
Ø 30 x 147 cm



**5500**  
Ø 30 x 52 cm



**5515**  
Ø 30 x 147 cm



**5505**  
Ø 30 x 52 cm

PMMA shade: Refs. 5500, 5510

- 07 Graphite and green (RAL 7016 and RAL 6026)
- 08 Graphite and orange (RAL 7016 and RAL 2009)

Steel shade: Refs. 5505, 5515

- 20 Gold (Gold)
- 67 Copper (Copper)

Colour shade: Refs. 5505, 5515

- 18 Graphite (RAL 7016)
- 23 Warm White (NCS S 0502-Y50R)
- 25 Beige D1 (NCS S 4005-Y50R)
- 38 Terra Dark (NCS S 5040-Y70R)
- 47 Green L1 (NCS S 4005-G80Y)

Finish customization  
(Available options: Vibia colour palette)

Diffuser: PC- Polycarbonate  
Tube: Steel  
Base: Zinc Alloy

**LED Colour Temperature**  
2700 K  
CRI>90

**Control**  
Analog: Optical sensor

Floor: Optical sensor on shade  
Table: Optical sensor on base

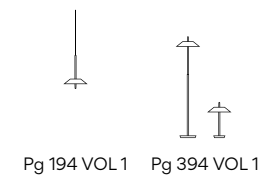

Pg 194 VOL1 Pg 394 VOL1

# Balance

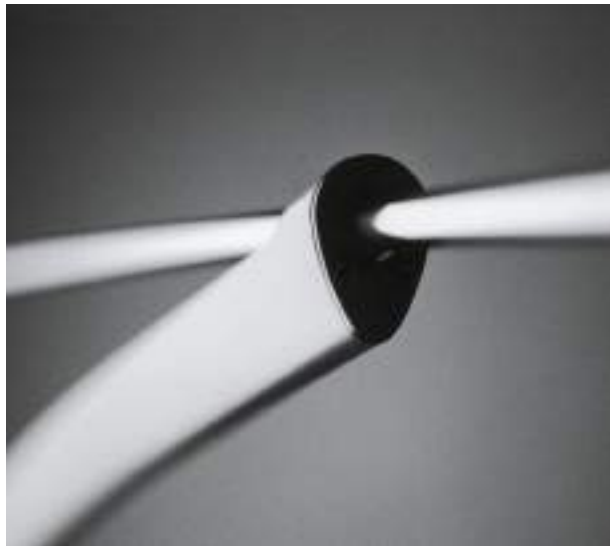

Design by Jordi Vilardell.

Balance features a classic drum shade, elegantly cantilevered from its column to provide a general ambient lighting effect or a more focused reading light.



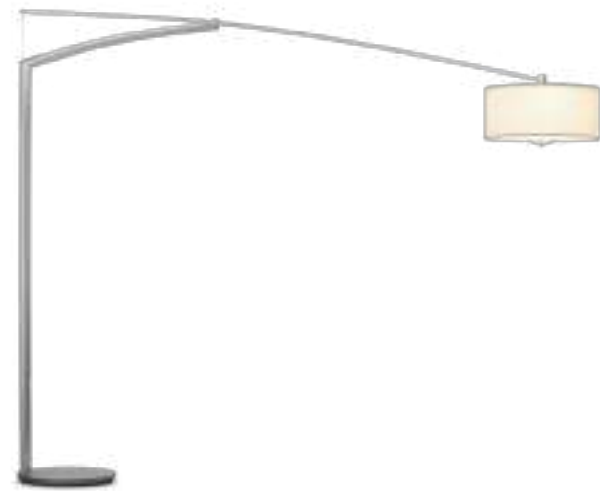

5189 5190

260 x 210 cm



5191 5192

215 x 210 cm

The Balance floor lamp serves multiple requirements simultaneously.

Illuminating a variety of spaces with its simple movement - it functions as a dining room lamp, an ambient living room light, or a reading lamp for work purposes.

Evoking the essence of its namesake, the drum shade is poised on a metal rod cantilevered from its steel column.

Adjusting a small pull piece on the diffuser activates the fixture's counterweight system, enabling it to move to the right or left, or up or down - all the while remaining parallel to the floor.

- 18 Graphite (RAL 7016)
- 30 Nickel (Metallic finish)

Shade: Parchment paper/ Aluminum  
Vertical tube: Aluminum  
Base: Steel  
Arm: Stainless steel

**LED Colour Temperature**  
2700 K

**Control**  
Analog: Push



# Flat

Design by Ichiro Iwasaki.

A study in geometry, the Flat collection features distinctive, disc-shaped diffusers that form horizontal planes of light, infusing a space with pools of soft illumination.







The LED-powered collection features flat metal plates reflecting light off their surface, casting an enveloping, wraparound glow that appears illuminated from within. The floor lamp comes in small and large sizes, with a single or double plate - either a compact disc or a shelf-like plate that doubles as furniture. When deployed in pairs, the smaller, complementary disc captures and reflects light back at the larger plate, creating pockets of soft, pooled indirect light that illuminate both the space and the surface itself.





**5965**  
35 x Ø 30 x 16 cm



**5970**  
29 x 17 x 30 cm



**5972**  
11 x 30 cm

Bolt-down

Ref. 5945, 5957, 5965

- 13 Off-White (NCS S 1000-N)
- 47 Green L1 (NCS S 4005-G80Y)

Ref. 5950

- 10 White (NCS S 0300-N)

Ref. 5955, 5970, 5972

- 11 Black (NCS S 8500-N)
- 37 Terra Red (NCS S 4040-Y70R)
- 47 Green L1 (NCS S 4005-G80Y)

Shade: Aluminum  
Diffuser: PC- Polycarbonate  
Structures: Steel

**LED Colour Temperature**

2700 K; 3500 K  
CRI>90

**Control**

Analog: Push

Ref. 5945

One general on/off and dimming  
switch for both discs



**5945**  
76 x 64 x 90 cm



**5950**  
Ø 55 x 43 cm



**5955**  
46 x 25 x 100 cm



**5957**  
48 x 35 x 96 cm

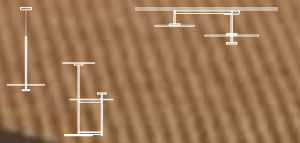

# North



Design by Arik Levy.

North features a base, stem, and shade that are disconnected from one another in a dynamic system of adjustable parts. Protruding arms hold triangular shades that direct the light where needed.





The North Floor Pendant is defined by a dynamic, deconstructed silhouette. It synthesises the typical floor and pendant lamp by connecting floor and ceiling, its sleek conical shade hanging from a slender carbon fibre rod and secured by a counterweight at floor level. The angle of the rod is adjustable, allowing light to be directed precisely over a coffee table or sofa.

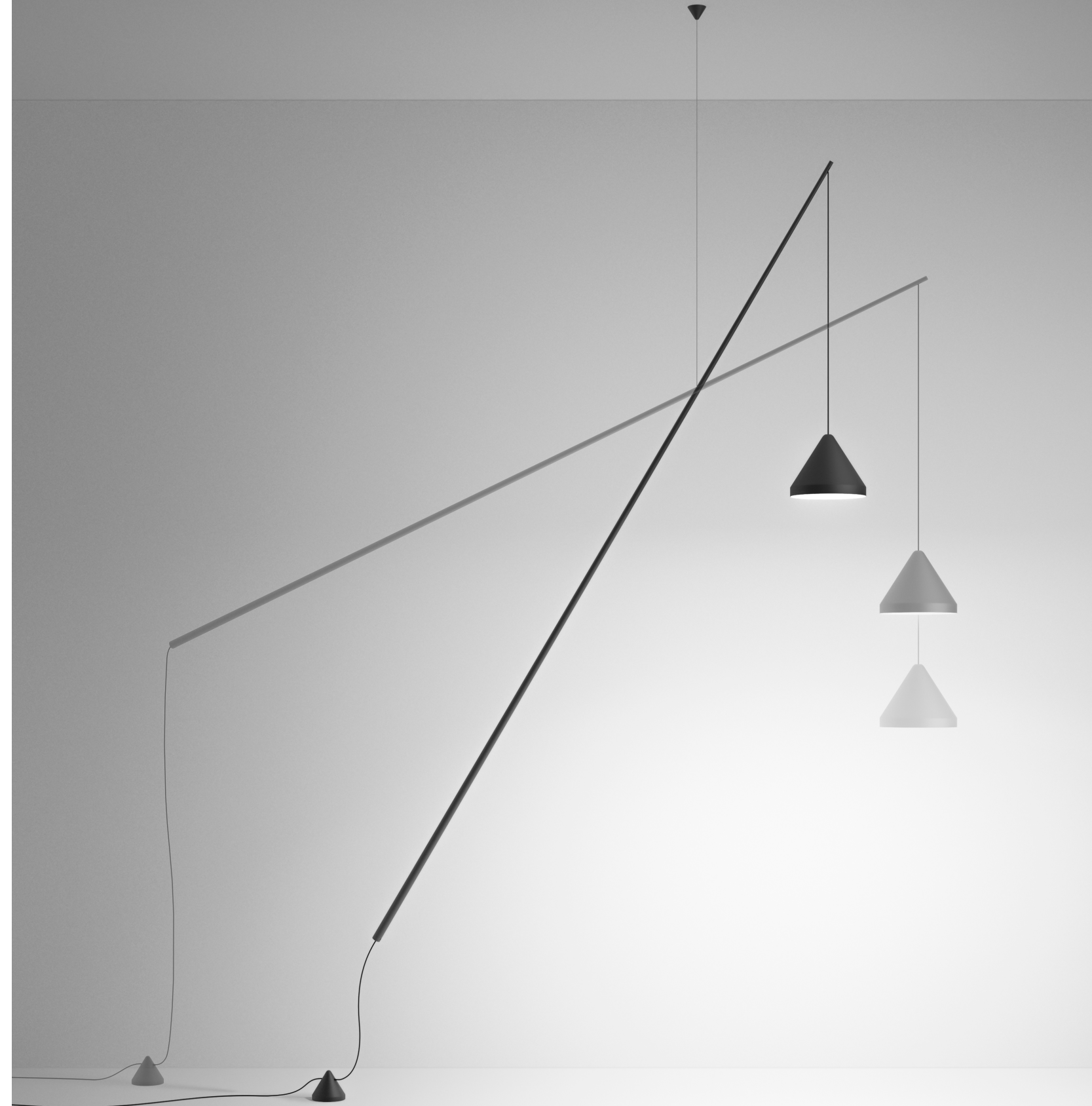



5666

max. 210 x max. 310 x max. 130 cm



5605

max. 270 x max. 230 x max. 355 cm



5620

max. 447 cm x max. 325 cm x max. 425 cm

- 10 White (NCS S 0300-N)
- 11 Black (NCS S 8500-N)
- 24 Beige M1 (NCS S 2005-Y50R)
- 42 Blue M1 (NCS S 5010-B10G)

Diffuser: PMMA  
 Shade: Aluminum  
 Rods: Carbon fiber  
 Base: Steel

**LED Colour Temperature**

LED 2700 K: CRI>90  
 LED 3000 K: CRI>80  
 LED 3500 K: CRI>90

**Control**

Analog: Push

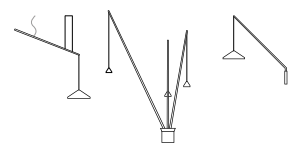



# Pin



Design by Ichiro Iwasaki.

A timeless proposal from Japanese designer Ichiro Iwasaki, the Pin is both classic and contemporary. Characterised by a graceful stem and subtle, functional expression, it is small in scale but with exceptional lighting efficiency.





Slick, refined and understated, the Pin floor lamp is a state of the art design. Perfect for reading, its simple geometric form is designed to arc playfully over a sofa or chair.

Offering two arm lengths, a single or double stem and with an adjustable head, the Pin table lamp provides versatile task lighting that's ideal for work spaces.





- 11 Black (NCS S 8500-N)
- 23 Warm White (NCS S 0502-Y50R)
- 58 Cream (NCS S 2500-Y20R)
- 62 Green (NCS S 3010-G20Y)

**LED Colour Temperature**

2700 K  
CRI>90

**Control**

Analog: On/ Off

Finish customization  
(Available options: Vibia colour palette)

Diffuser: PC- Polycarbonate  
Head: Aluminum  
Rods: Steel  
Base: Zinc Alloy



**1650**  
23 x 55 cm

**1655**  
40 x 55 cm

**1660**  
25 x 125 cm

**1670**  
35 x 143 cm



Pg 418 VOL 1 Pg 262 VOL 2

# I.Cono



Design by Lievore, Altherr, Molina.

Distinguished by its signature visor-shaped shade, I.Cono presents a poised presence. The visual purity of its angular shade is matched by a sleek base and stem and complemented by a range of elegant finishes.



I.Cono's smooth surfaces and refined silhouette conceal advanced mechanisms for rotating the head and metal base, ideal for precision lighting and reading.





- 10 White (NCS S 0300-N)
- 21 Grey D1 (NCS S 7000-N)
- 25 Beige D1 (NCS S 4005-Y50R)
- 37 Terra Red (NCS S 4040-Y70R)
- 42 Blue M1 (NCS S 5010-B10G)

Shade: ABS + PC- Polycarbonate  
 Tube: Metal  
 Base: Zinc Alloy

**LED Colour Temperature**  
 2700 K  
 CRI>90

**Control**  
 Analog: Push  
 Smart: Casambi; ProtoPixel\*  
 \*ProtoPixel products are compatible with all other DALI-2 products via a designated gateway (please consult us)

On/off switch on the cable

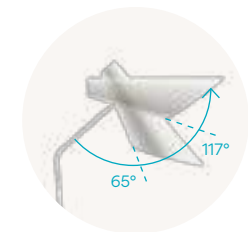

**0712**  
 21 x 129 x 35 cm



**0700**  
 17 x 56 x 32 cm

# Suite



Design by Jordi Vilardell & Meritxell Vidal.

Suite reimagines the traditional pairing of shelf and lamp. The collection consists of a set of shelves and a table lamp, with invisible ambient illumination adding an unexpected surprise.





On/off switch under the shelf.  
USB charging connection.

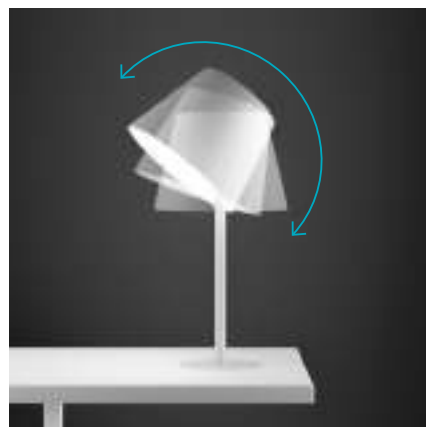

6007 and 6012.  
Reading light Mink (Pantone 407C),  
mounted on shelf with dimmable light.  
Dimming push-button under the shelf.

- 14 Chocolate (RAL 8019)
- 23 Warm White (NCS S 0502-Y50R)

Finish customization  
(Available options: Vibia colour palette)

Diffuser: PC- Polycarbonate  
Shelf: Aluminum  
Lid: ABS with fiberglass  
Vertical tube: Steel  
Base: Steel

**LED Colour Temperature**  
2700 K  
CRI>90

**Control**  
Analog: Push



**6006**  
46 x 46 x 133 cm



**6007**  
46 x 46 x 133 cm



**6011**  
46 x 39 x 97 cm



**6012**  
46 x 39 x 112 cm

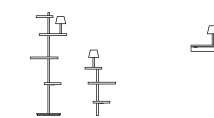



# Skán



Design by Lievore, Altherr, Molina.

Skán is a sleek and unadorned fixture. It combines lean lines with soothing purity of form, adding a minimalist sensibility to any space.



Characterized by simple shapes that exude an unmistakable elegance, the Skan floor lamp features flat, disc-like shades which emit a diffuse, comfortable uplight. Three slender stems are entwined like a group of trees, the body and head available in various contemporary matte finishes.

- 10 White (NCS S 0300-N)
- 11 Black (NCS S 8500-N)
- 37 Terra Red (NCS S 4040-Y70R)

Finish customization  
(Available options: Vibia colour palette)

Head: Aluminum  
Diffuser: PMMA  
Vertical tube: Steel

**LED Colour Temperature**  
2700 K; 3000 K; 3500 K  
CRI>90

**Control**  
Analog: Push



**0260**

43 x 37,5 x 198 cm

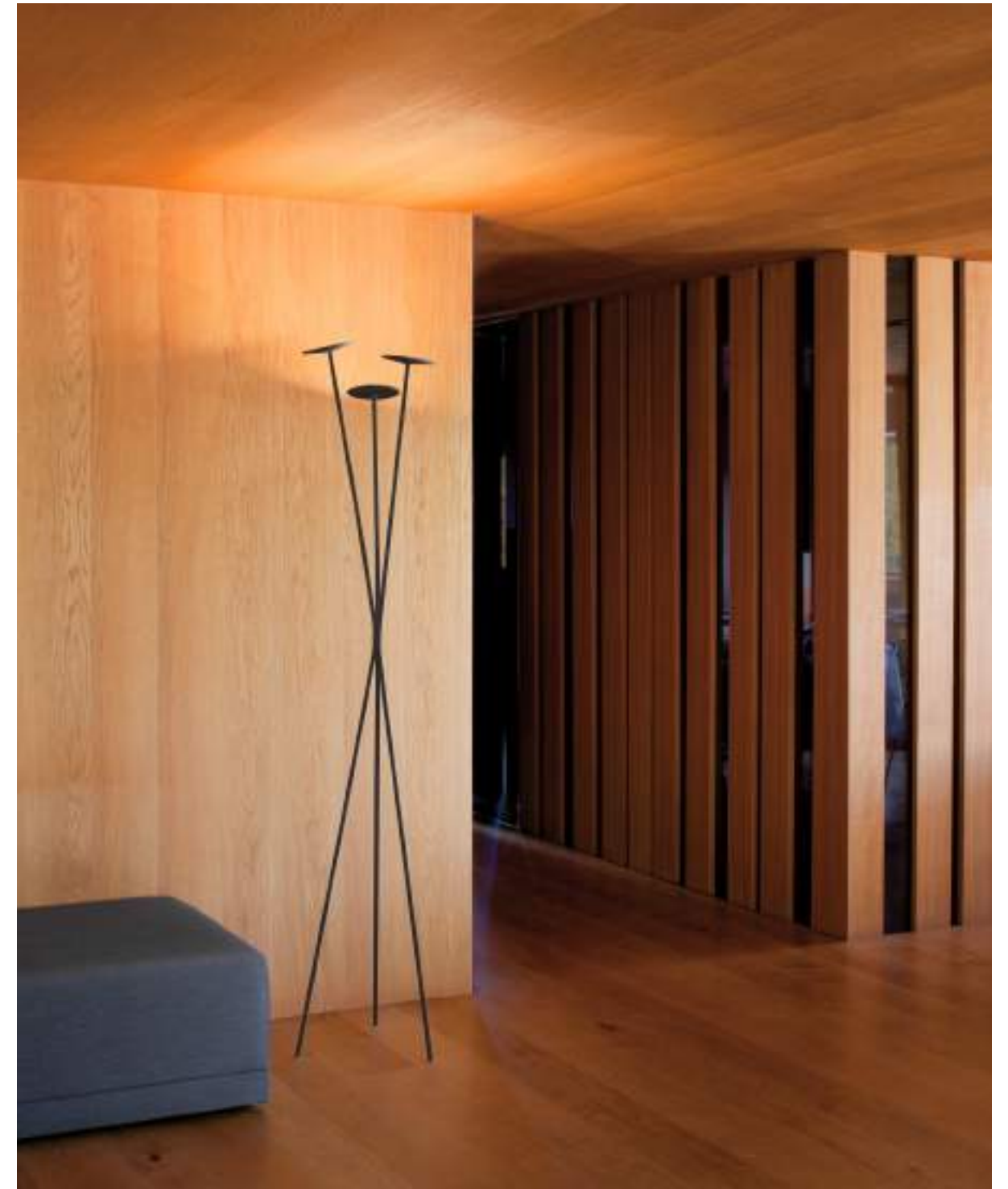

# Ghost



Design by Arik Levy.

A study in contrasts, the Ghost collection embodies both spirit and materiality, discretion and presence. A contemporary reimagining of the grand lights that once graced entryways and living areas, its sensuous form radiates with a warm, welcoming glow.



The Ghost table lamp features a stacked silhouette of voluminous forms to offer an enveloping luminous effect. A black band encircles the midsection, accentuating its sensuous curves while serving as a hand-touch dimmer.

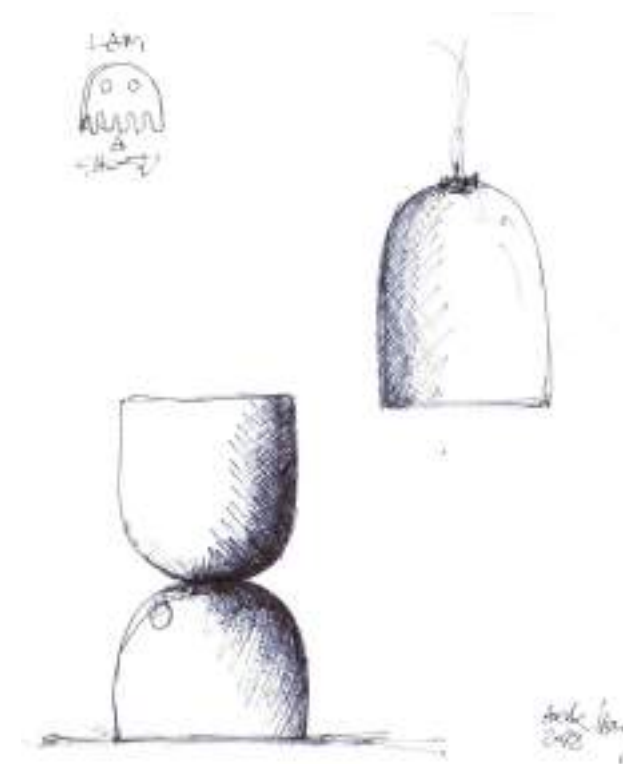

“Ghost is the pure expression of a state of mind, of the immateriality of mouthblown glass that projects a sensuous halo in space”.

Arik Levy



**4960**  
Ø 47,5 x 112 cm



**4965**  
Ø 47,5 x 92 cm



**4970**  
Ø 47,5 x 88 cm

● 11 Black (NCS S 8500-N)

Diffuser: Opal Glass  
Metal parts: Aluminum

**LED Colour Temperature**

2700 K  
CRI>90

**Control**

Analog: Push; 1-10V  
Digital: DALI-2  
Smart: Casambi



/\_5: Push-dimming model equipped with two buttons, one for each diffuser. A quick push turns the light on and off, a longer presson dims the light.

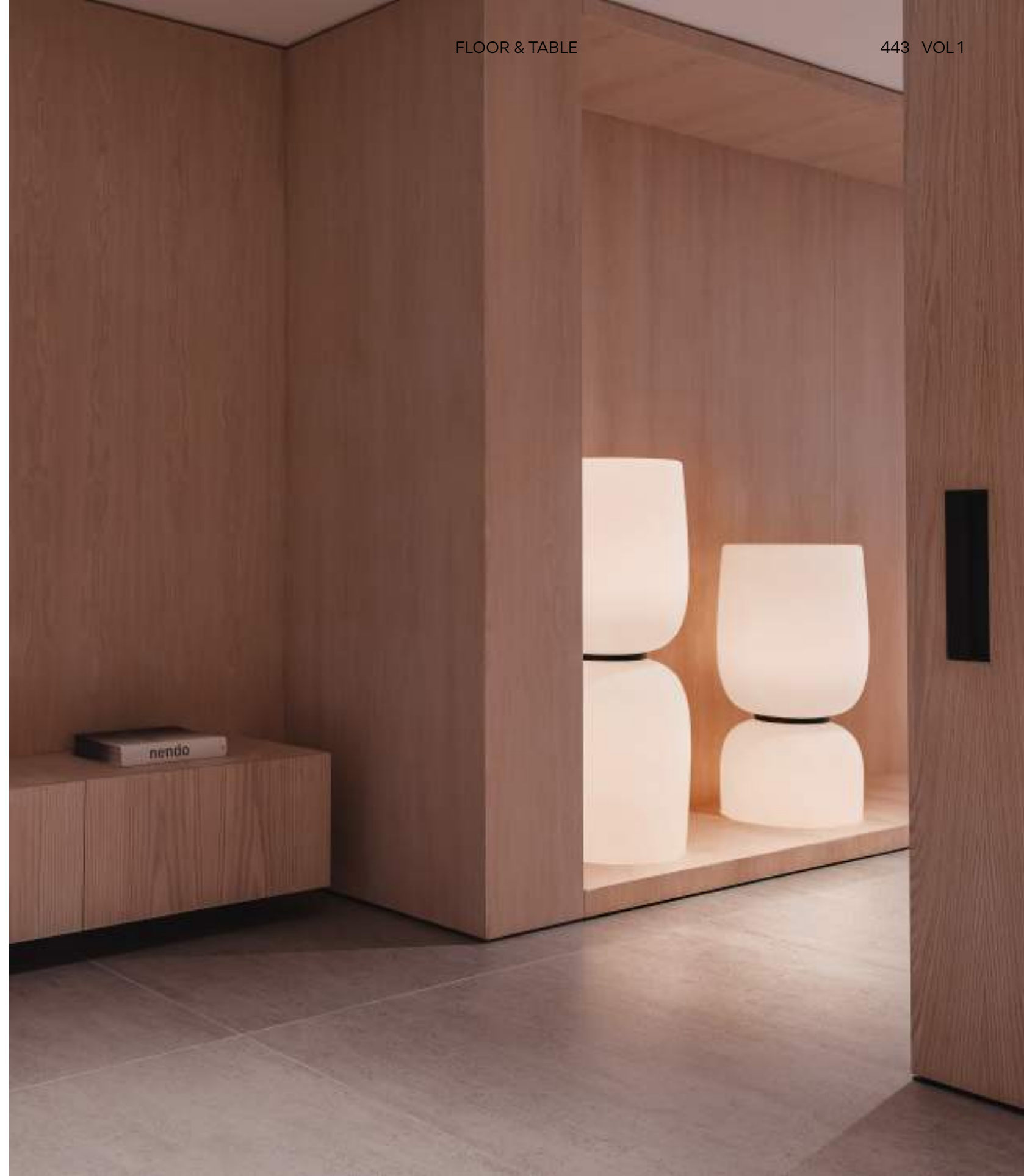
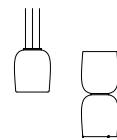

# Jazz

Design by Diego Fortunato.

Undulating and fluid, Jazz's smooth silhouette is strikingly organic. The gently curved design imparts a playful presence, like an oversized chess piece standing guard.





**1329**  
 Ø 25 x 190 cm

- 10 White (NCS S 0300-N)
- 25 Beige D1 (NCS S 4005-Y50R)
- 45 Blue D1 (NCS S 7010-B10G)

Body: PU- Polyurethane  
 Diffuser: PC- Polycarbonate

**LED Colour Temperature**

LED 2700 K  
 CRI>90

**Control**

Analog: Push  
 Smart: Casambi; ProtoPixel\*

\*ProtoPixel products are compatible with all other DALI-2 products via a designated gateway (please consult us)



Floor switch



# Warm

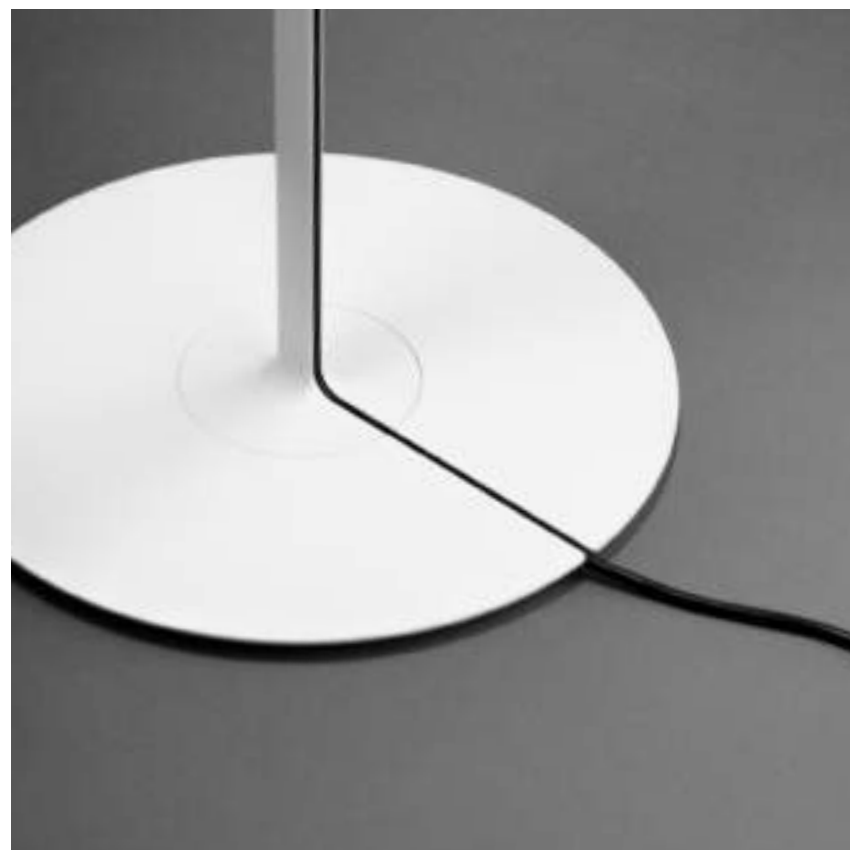

Design by Ramos & Bassols.

A contemporary take on a timeless design, Warm features a generous drum shade in a muted colour palette for a refined touch.





Bringing a touch of elegance that's adaptable to any atmosphere, Warm is available in two models: the translucent screen provides general ambient illumination and the opaque aluminium shade offers a brighter, up- and downlight.

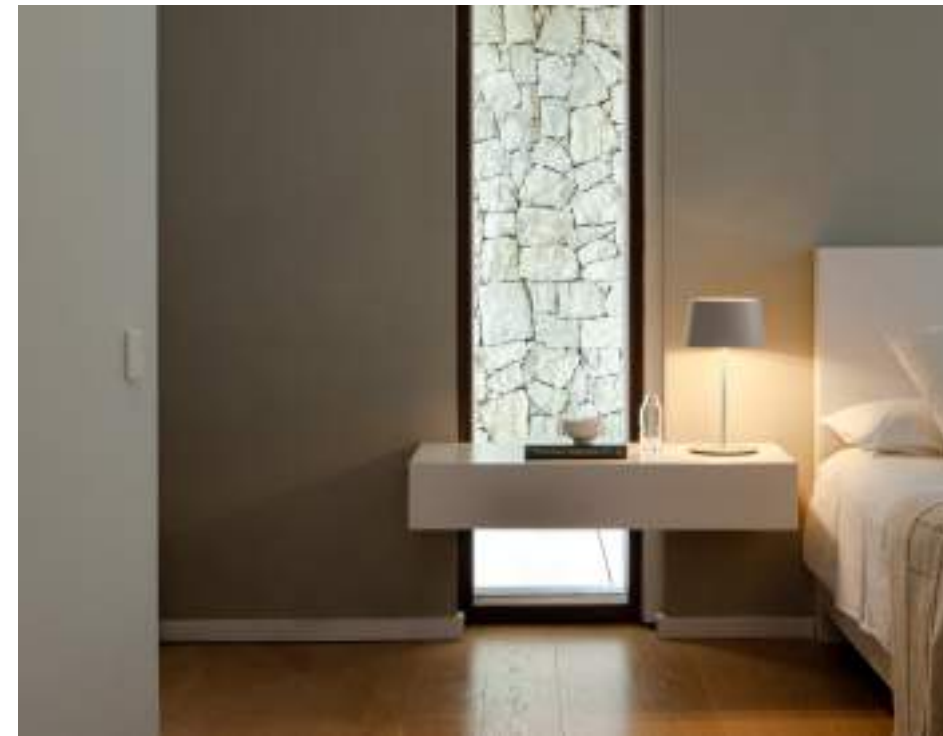
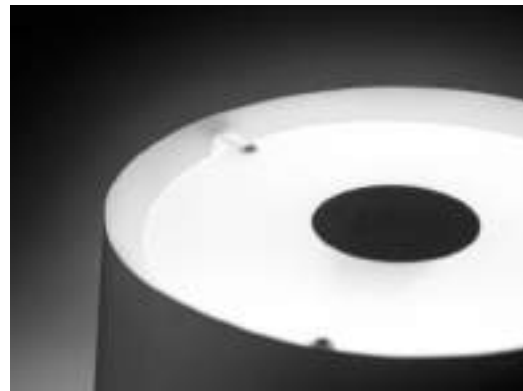



**4895 4896**  
Ø 19 x 41 cm



**4900 4901**  
Ø 32,4 x 59 cm



**4905 4906**  
Ø 32,4 x 150 cm

Screen shade: Ref. 4895, 4900, 4905

- 10 White (NCS S 0300-N)

Aluminum shade: Ref. 4896, 4901, 4906

- 10 White (NCS S 0300-N)
- 25 Beige D1 (NCS S 4005-Y50R)
- 28 Brown M1 (NCS S 4020-Y60R)
- 56 Green D1 (NCS S 7010-G30Y)

Finish customization  
(Available options: Vibia colour palette)

Diffuser: PMMA  
Rod: Aluminum  
Base: Steel

**LED Colour Temperature**  
2700 K

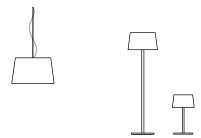

Pg 122 VOL 1 Pg 448 VOL 1



# Musa

Design by Note Design Studio.

A poetic lighting solution, Musa is inspired by the beauty of nature. Its delicate silhouette consists of two ovals: a milky-white blown-glass shade and an LED-powered bulb cradled within.





Refs. 7400, 7402.  
Electric cable with plug.  
Push-button on the base.



Ref. 7404.  
Portable version with battery.  
Electric cable with plug.  
Push-button on the base.

**7400**

9 x Ø 26 cm

**7402 7404**

Ø 26 x 14 x 10 cm

As a table lamp, its smooth bowl rests on an aluminium base that's tucked behind the body so as not to disrupt the design. A small, dimmable bulb nestles at its base, casting a soft glow that spreads across the larger sphere which contains and diffuses it.

- 23 Warm White (NCS S 0502-Y50R)
- 24 Beige M1 (NCS S 2005-Y50R)
- 36 Soft Pink (NCS S 1010-Y50R)

Finish customization  
(Available options: Vibia colour palette)

Diffuser: Blown-glass  
Body: Aluminum

**LED Colour Temperature**

2700 K  
CRI>90

**Control**

Analog: Push

Ref: 7404

Portable

Battery life: from 6 to 18 hours  
(depending on intensity)



# Offset



Design by Xuclà.

Offset consists of a vertical rod extending from a solid base. The rod can be angled to illuminate an adjacent wall with a diffuse, ambient lighting effect. A combination of multiple fixtures of different lengths adds a graphic dimension to a contemporary interior.

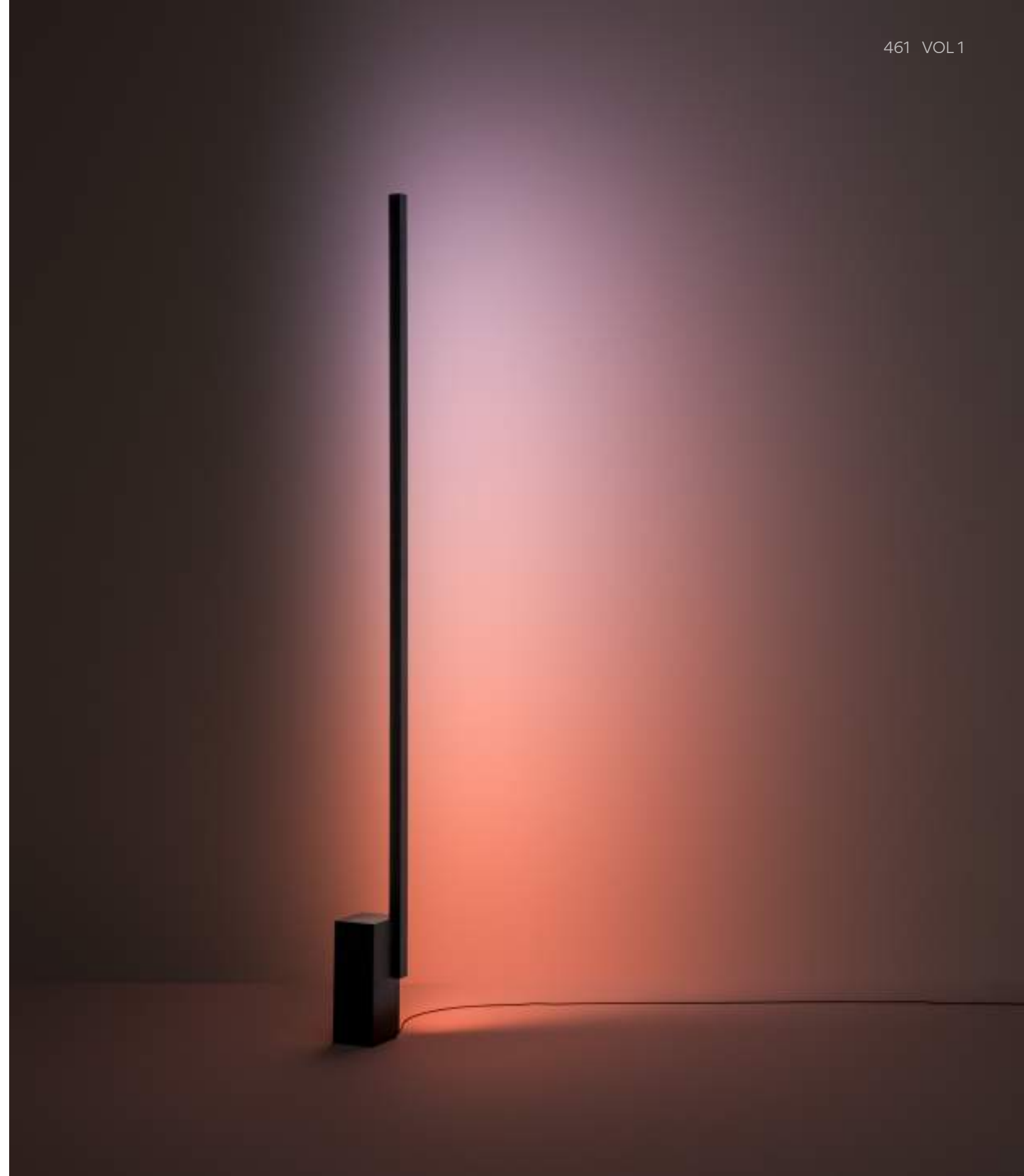



Never harsh or obvious, these are thoughtful, ultra-nuanced colours that respect and reflect the characteristics of natural light while capturing or enhancing a desired mood or moment. Applicable to day and night and every hour in between, each hue has an adaptable tone that can be tailored to any scenario or space.

Whatever the situation, these are illuminating tones that set the stage for life in all its colourful complexity.

## A source of emotion

Colour is a source of emotion it can instantly set a mood, convey a feeling or generate a sense of wellbeing

Vibia's approach to coloured light invites the use of colour and gradients to create and experience different atmospheres, making them as natural and subtle as possible. Natural light is never mono-tonal. Gradients come in infinite colours.

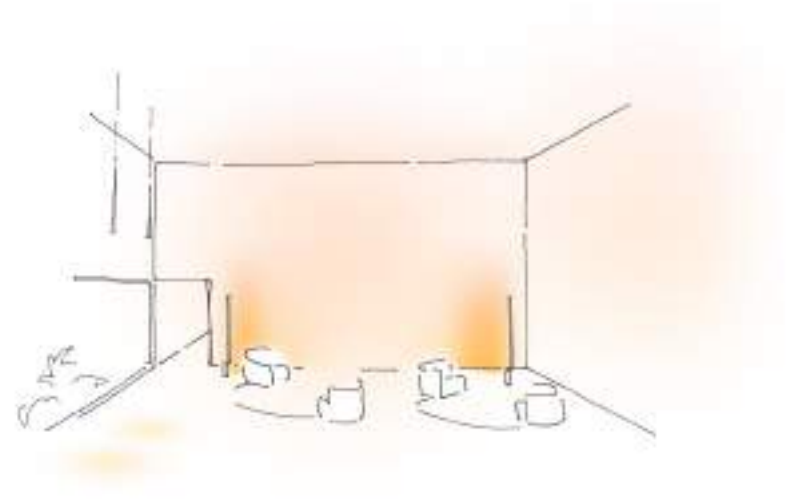

## Vibia Chromatica colours of light

### Static White

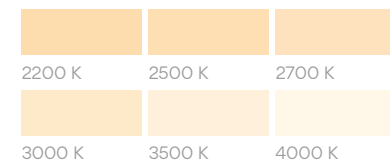

You can select any desired light -white, colour mood or gradient- and intensity manually from the analogic product interface. You can also integrate your selection into the control system for specific scene design and activate it using the Vibia App

### Colour Moods

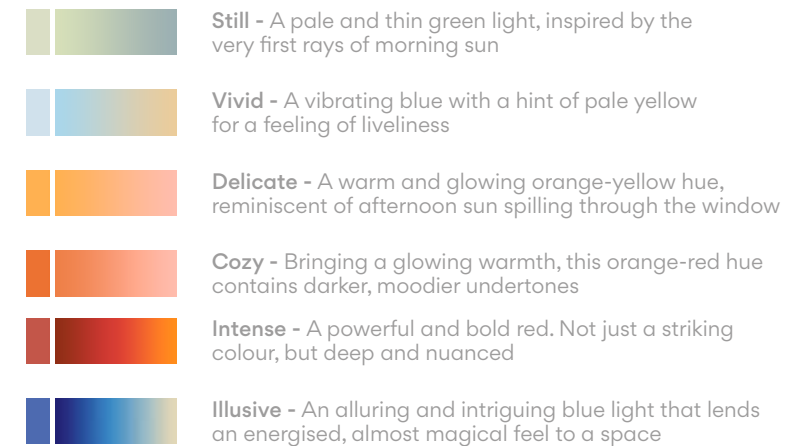

Contact Vibia Support Service at [vibia.com](http://vibia.com) for any kind of assistance or recommendation when designing an atmosphere of wellbeing, or if you require support with control system approach.

## Delicate colour mood

A warm and glowing orange-yellow hue, reminiscent of afternoon sun spilling through the window. Golden tones from apricot pink to soft orange meet in the gradient.

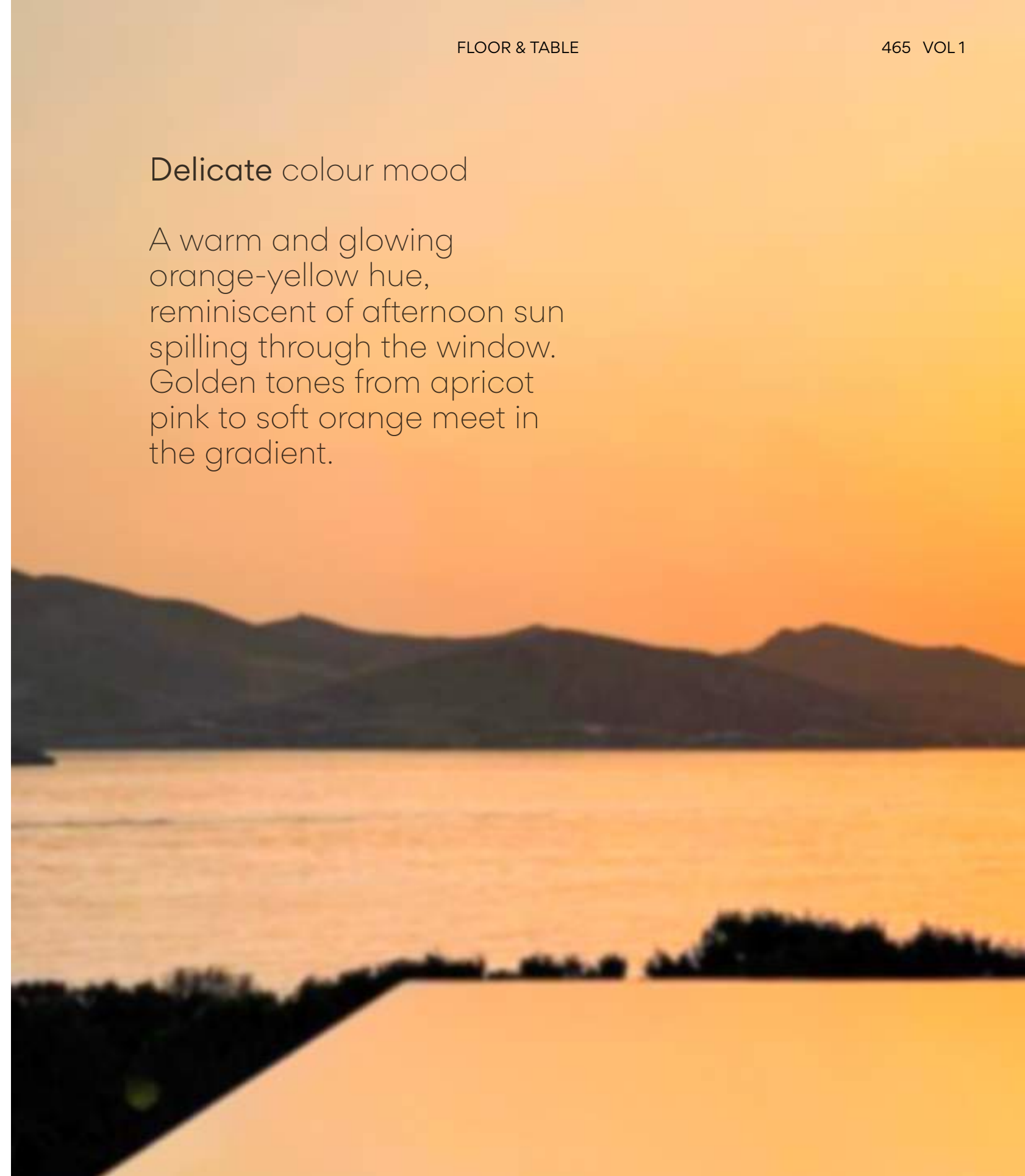



## Colour Mood Grazer

- 11 Black (NCS S 8500-N)
- 23 Warm White (NCS S 0502-Y50R)
- 24 Beige M1 (NCS S 2005-Y50R)

Body: Aluminum  
Lens: PMMA

### LED Colour Temperature

Infinite Colour (TW + RGB)  
CRI >90

### Control

Smart: ProtoPixel\*  
(also with push buttons)

\*ProtoPixel products are compatible with all other DALI-2 products via a designated gateway (please consult us)

You can select any desired light -white, colour mood or gradient- and intensity manually from the analogic product interface

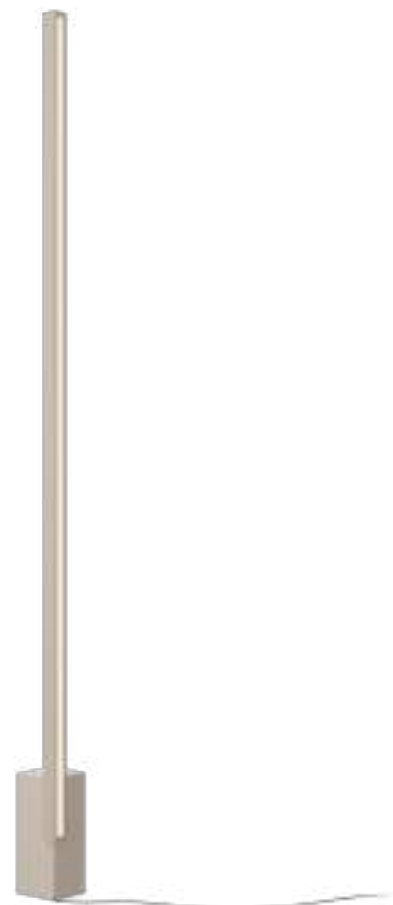

1780

14 x 128 cm



Pg 460 VOL 1 Pg 94/348 VOL 2



# Out



Design by Víctor Carrasco.

A romantic response to the global transition to life outside, Out brings the intimacy of indoor lighting outdoors. Suitable for illuminating a table or meeting point, this luminaire emanates with a soft, diffuse downlight.





**4270 Not Fixed**  
211 x 242 cm



**4275 Bolt-down "hard wired"**  
211 x 242 cm

- 22 Graphite Black (NCS S 8000-N)
- 23 Warm White (NCS S 0502-Y50R)
- 25 Beige D1 (NCS S 4005-Y50R)
- 36 Soft Pink (NCS S 1010-Y50R)
- 37 Terra Red (NCS S 4040-Y70R)
- 47 Green L1 (NCS S 4005-G80Y)

Tube: Stainless Steel  
Shade: Aluminum  
Diffuser: PE- Polyethylene

**LED Colour Temperature**  
2700 K  
CRI>90

**Control**  
Ref. 4270  
Analog: Push  
Smart: Casambi; ProtoPixel\*  
\*ProtoPixel products are compatible with all other DALI-2 products via a designated gateway (please consult us)  
Ref. 4275  
Digital: DALI-2  
Smart: Casambi (Remote)

4270. Cable with switch **IP44**



**IP65**

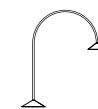

# Plusminus Solo

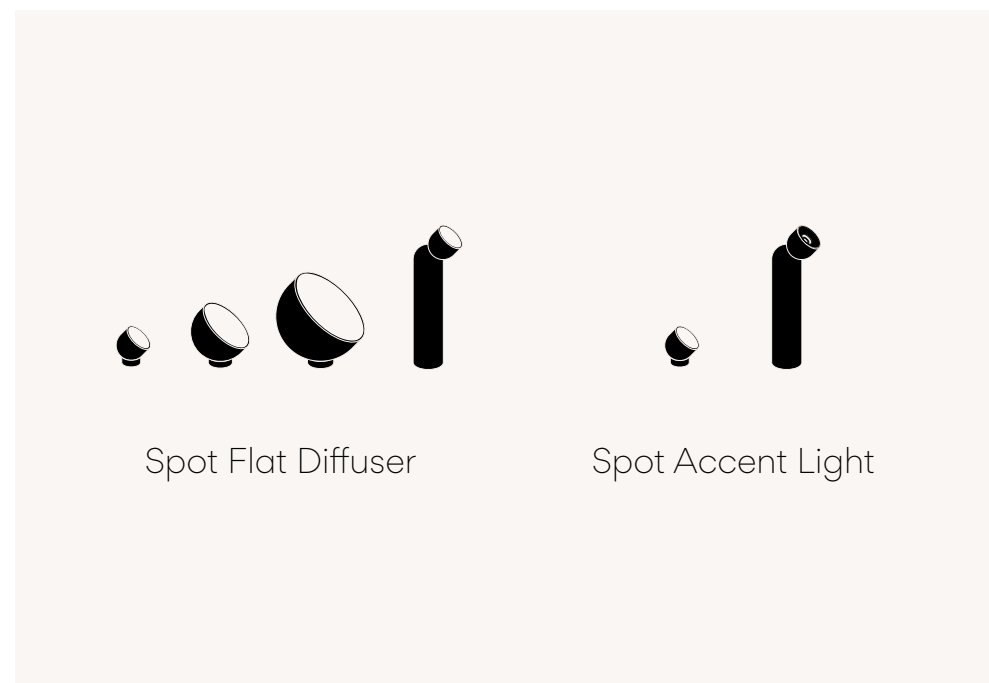

Design by Diez Office.

Introducing a collection of versatile semispheres, Plusminus Solo offers complete freedom to create dynamic and restorative atmospheres. A combination of various typologies unlocks harmonious effects, from diffuse and general through to accented lighting.





Table switch







Floor switch



Plusminus Solo offers two distinct designs, visually connected by their signature semi-spherical shades. A range of dome-shaped flat diffusers can be positioned as desired, directed upwards from floor level or tilted at an angle. A compact floor or table lamp completes the set. With a thick cylindrical base and adjustable shade, this portable model provides accent or diffuse spotlighting wherever needed.



**6341** Surface Accent medium

**6343** Surface Flat diffuser

Ø 10 x 50 cm

**6346** Bolt-down Accent medium

**6348** Bolt-down Flat diffuser

Ø 10 x 50 cm

- 11 Black (NCS S 8500-N)
- 24 Beige M1 (NCS S 2005-Y50R)
- 37 Terra Red (NCS S 4040-Y70R)
- 42 Blue M1 (NCS S 5010-B10G)
- 53 Green M1 (NCS S 6005-G80Y)

Body: Aluminum  
 Base: Steel / Zinc Alloy  
 Diffuser: PC- Polycarbonate

**LED Colour Temperature**  
 2700 K; 3000 K; 3500 K  
 CRI>90

**Control**  
 Analog: Push  
 Digital: DALI-2 (Bolt-down)  
 Smart: Casambi; ProtoPixel\*  
 \*ProtoPixel products are compatible with all other DALI-2 products via a designated gateway (please consult us)



**6361**  
 Surface / Bolt-down  
 Accent medium

**6363**  
 Surface / Bolt-down  
 Flat diffuser

Ø 10 x 10 cm



**6365**  
 Surface / Bolt-down  
 Flat diffuser

Ø 20 x 14 cm



**6370**  
 Surface / Bolt-down  
 Flat diffuser

Ø 30 x 20 cm



Pg 472 VOL 1 Pg 120/216 VOL 2







Lighting Typologies

Support Portfolio

# Lighting Typologies

## Diffuse

---



Flat Diffuser



General Proximity Linear Linear High Comfort

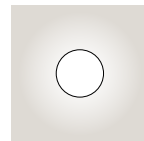

Volumetric Diffuser

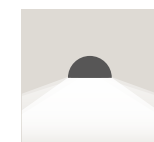

Hidden Diffuser

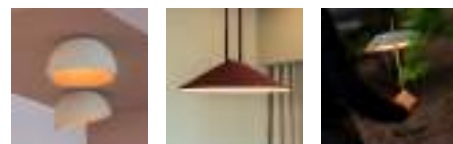

General Proximity

## Indirect

---

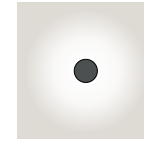

Reflected

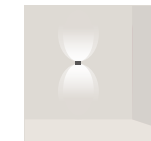
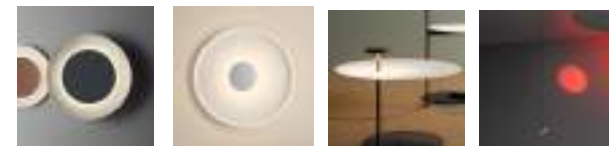

Surface Grazer



360° Direct Mood Grazer



Wall Washer

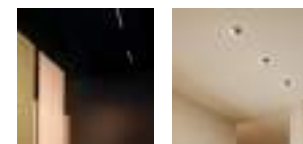

Linear Spot

## Direct

---



Spotlight

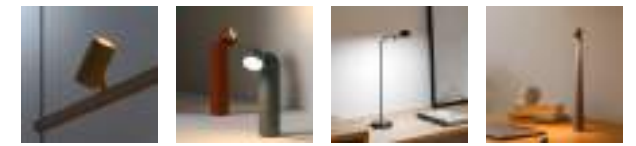

Accent Reading



Downlight



Accent



Linear High Efficiency Low Glare



## Lighting Typologies

## Diffuse

## Flat Diffuser



Comfortable, uniform illumination with soft shadows, subdued highlights and little visual hierarchy



**General**  
First layer of basic, general illumination



**Close Proximity**  
Lighting applications for illumination in close proximity to the user



**Linear**  
Linear lighting applications for functional and graphic illumination



**Linear High Comfort**  
Linear lighting applications with High lighting and comfort levels (UGR <19) for illumination in close proximity

## Volumetric Diffuser

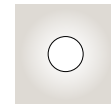

Subtly directed, diffused light that generates a soft hierarchy of light on to the illuminated surface.



## Hidden Diffuser

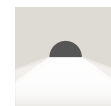

Subtly directed diffused light that generates a soft hierarchy of light on to the illuminated surface



**General**  
First layer of basic, general illumination

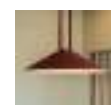

**Close Proximity**  
Lighting applications for illumination in close proximity to the user

## Indirect

## Reflected



Creation of visual hierarchies within the luminaire itself, emphasising the materiality and texture of the product

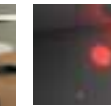
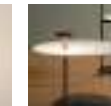
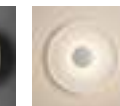

## Surface Grazer



Creation of visual hierarchies through projected light, emphasising the materiality and texture of the surrounding environment



**360°**  
Full-circle grazing light



**Direct**  
Directed grazing light

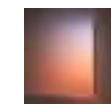

**Mood Grazer**  
Tunable white or infinite colour regulation to curate the perfect atmosphere

## Wall Washer



Vertical lighting to give structure and amplitude to a space. Diffuse light is reflected from the illuminated surface for a soft and homogeneous atmosphere

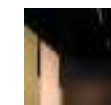

**Linear**  
Bathing a vertical surface with light projected from a linear lighting application



**Spot**  
Bathing a vertical surface with light projected from a spot lighting application

## Direct

## Spotlight



Adjustable, directed light for dynamic visual hierarchies, emphasising functional areas, objects or architectural elements

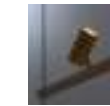

**Accent**  
Narrow: Angles less than 20°. Suitable for generating high contrasts or projections at far distances.

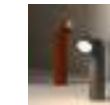

Medium: Angles between 20° and 40°. Suitable for generating medium contrasts or projections at medium distances.

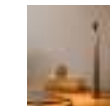

Wide: Angles greater than 40°. Suitable for generating moderate contrasts or projections at near distances.

**Reading**  
High intensity, glare-free task lighting

## Downlight



Static, directed light for creating visual hierarchies and emphasising functional areas, objects or architectural elements



**Accent**  
Narrow: Angles less than 20°. Suitable for generating high contrasts or projections at far distances.



Medium: Angles between 20° and 40°. Suitable for generating medium contrasts or projections at medium distances.

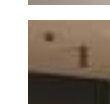

Wide: Angles greater than 40°. Suitable for generating moderate contrasts or projections at near distances.

## Linear High Efficiency Low Glare



High energy efficiency and low glare levels UGR<19 for linear light applications



# Support Portfolio



## From Project Support to Usage

To achieve wellbeing scenes it is necessary to cover the entire end-to-end journey. From **design** and composition through to **installation** and **user interaction**, Vibia's team is prepared to assist you in any request you may have.

### Sales Team Project Support

Direct contact with the Vibia representative in your area to assist you with whatever you need.

Selection of the appropriate product and customisation.

Creation of project moodboards by scenes.

Use of Vibia's online professional tools (Website, App, etc.).



### Lighting & Wellbeing Studio

Vibia's specialised team is at your disposal to assist you in creating a complete Atmosphere Design project, including:

**Scenes design.**

**Optional:**

Lighting calculations, renderings, etc.

Control system approach.

End-user interaction approach.



Lighting Project Design with Scenes

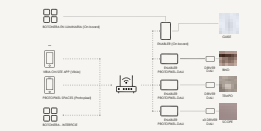

Control System and End-User Interaction Approach

### Technical Support Services (TSS)

Our technical service team is available to assist you with any post-sales queries you may have, including:

Installation process.

Control System implementation process.

Maintenance.

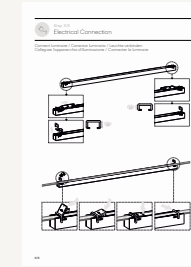

Installation and Maintenance Process

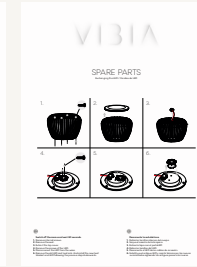

Control System Implementation



CASAMBI

ProtoPixel

### Online Professional Tools

Support for our digital tools designed for professionals.

**Web: Professional Area.**

**Onsite App.**



Web Project Management Area

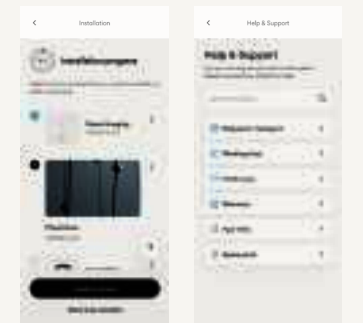

Onsite App

### Atmosphere Design Content and Professional Training

Consult about Vibia's training program.

**New Approach to Atmospheres Design:**

Periodic online training sessions.

In-company training.

**Certification Programs: COMING SOON.**

Certificate in Emotional Atmosphere Design for project designers.

Certificate for Vibia Authorised Installers to provide local support.



Events for professionals





Vibia Lighting, S.L.U.

Spain & Portugal T. +34 934 796 970

International T. +34 934 796 971

[hello@vibia.com](mailto:hello@vibia.com)

[www.vibia.com](http://www.vibia.com)



# Atmosphere Design

A space is an ecosystem; a combination of different elements that come together to create an atmosphere. With the right tools, a designer can shape the atmosphere of a space.

What determines our sense of wellbeing is the type of space and how individuals use it; the visual hierarchy and harmony created by the composition and combination of material and spatial elements; and the fusion of different lighting effects as they accompany us throughout the day.

1

PENDANT  
PLUSMINUS  
FLOOR & TABLE

2

CEILING  
WALL  
OUTDOOR



VIBIA

## A New Approach to Atmosphere Design

A space is an ecosystem; a combination of different elements that come together to create an atmosphere. With the right tools, a designer can shape the atmosphere of a space.



What determines our sense of wellbeing is the type of space and how individuals use it; the visual hierarchy and harmony created by the composition and combination of material and spatial elements; and the fusion of different lighting effects as they accompany us throughout the day.

Designing the perfect atmosphere requires the consideration of **scene composition** and **control system integration** from the beginning of a project.



# Lighting Project Design with Scenes

Design by Use & Emotions

Visual Hierarchy

Density of Light

## Design by Use & Emotions

Relaxation



Activation



Concentration



Socialisation

Designing by use and emotions involves exploring how individuals might use a space and designing **adaptable scenes** to suit their needs, considering how people might like to feel at **certain times of day** and how the atmosphere of the space might enhance these emotions.

## Visual Hierarchy



Considering the key elements of the interior and create visual hierarchy using light to **direct the gaze** and highlight certain aspects of the space. **Light** and **material** elements come together to generate depth and harmony.

## Density of Light



The key is to find a balance between soft and more accentuated light through a **unique blend of lighting effects** (direct, indirect and diffuse) and subtle variations in **intensity, tone** and **colour gradient**.

## Control System Design

Designing the perfect atmosphere requires designing the control system right from the start of each project.

This facilitates the creation of hybrid scenes that **enhance wellbeing** while **reducing energy consumption and project costs**.

## Control System Integration



Our portfolio of products and digital tools are designed to seamlessly integrate with any control systems and Building Management Systems (BMS).

### Vibia Product Control Options

Analog (On/Off, Push, Sensor, TRIAC, 1-10V, 0-10V)  
Digital (DALI 2, Lutron)  
Smart (Casambi, ProtoPixel)

### Integration with

Control System (Wired, Wireless)  
Building Management Systems (BMS)  
Used in large buildings to ensure centralised control and energy savings.



## End User Interaction Design



Incorporating end user interaction and automation from the beginning of every lighting project is essential. This ensures that the design is intuitive and responsive to user needs, enhancing the overall experience.

### User Interfaces

Switches, apps, and voice assistants for simplified light interaction.

### Automation

Use of time control. Smart sensors trigger lighting adjustments automatically.

## Scenes & Control System Design Support



We offer personalised support with **control system approach**, as well as assistance and recommendation when designing an atmosphere of wellbeing.

# By Your Side

## From Project Support to Usage.

Creating scenes of wellbeing requires guidance and support throughout the entire project journey (end-to-end). From **design** and composition through to **installation** and **end-user interaction**, Vibia's team is prepared to help you with any technical or commercial need you might have.



Volume

1

|                     |     |
|---------------------|-----|
| Pendant             | 1   |
| Plusminus           | 271 |
| Floor & Table       | 355 |
| Lighting Typologies | 486 |
| Support Portfolio   | 490 |
| Item index          | 492 |
| Acknowledgements    | 495 |

Volume

2

|                     |     |
|---------------------|-----|
| Ceiling             | 1   |
| Wall                | 209 |
| Outdoor             | 359 |
| Lighting Typologies | 472 |
| Support Portfolio   | 476 |
| Item index          | 478 |
| Acknowledgements    | 481 |

# Collections

## Africa

**Floor & Table**  
Vol1 356

## Algorithm Free

**Pendant**  
Vol1 200

## Algorithm Grid

**Pendant**  
Vol1 206

## Alpha

**Wall**  
Vol2 316

## Array

**Pendant**  
Vol1 2

## Balance

**Floor & Table**  
Vol1 400

## Bamboo

**Outdoor**  
Vol2 414

## Bigger

**Pendant**  
Vol1 176  
**Ceiling**  
Vol2 202

## Bind

**Pendant**  
Vol1 240  
**Ceiling**  
Vol2 128

## Bind Solo

**Ceiling**  
Vol2 148

## Break

**Outdoor**  
Vol2 430

## Break Plus

**Outdoor**  
Vol2 435

## Brisa

**Outdoor**  
Vol2 402

## Circle

**Ceiling**  
Vol2 18

## Circus

**Pendant**  
Vol1 32  
**Ceiling**  
Vol2 42

## Circus Solo

**Pendant**  
Vol1 56  
**Ceiling**  
Vol2 62

## Class

**Outdoor**  
Vol2 456

## Cosmos

**Pendant**  
Vol1 160

## Dama

**Pendant**  
Vol1 20  
**Floor & Table**  
Vol1 364

## Dots

**Wall**  
Vol2 242

## Dots Glass

**Wall**  
Vol2 252  
**Outdoor**  
Vol2 372

## Dots Outdoor

**Outdoor**  
Vol2 360

## Duo

**Ceiling**  
Vol2 2

## Duo Petra

**Ceiling**  
Vol2 12

## Empty

**Outdoor**  
Vol2 408

## Flamingo

**Pendant**  
Vol1 154

## Flamingo Mini

**Pendant**  
Vol1 144

## Flat

**Pendant**  
Vol1 94  
**Floor & Table**  
Vol1 405  
**Ceiling**  
Vol2 68

## Funnel

**Ceiling**  
Vol2 172  
**Wall**  
Vol2 300

## Ghost

**Pendant**  
Vol1 90  
**Floor & Table**  
Vol1 438

## Guise

**Pendant**  
Vol1 110  
**Ceiling**  
Vol2 168  
**Wall**  
Vol2 288

## Halo

**Pendant**  
Vol1 218  
**Wall**  
Vol2 336

## Halo Jewel

**Pendant**  
Vol1 224

## I.Cono

**Floor & Table**  
Vol1 424  
**Wall**  
Vol2 308

## Jazz

**Floor & Table**  
Vol1 444

## June

**Outdoor**  
Vol2 446

## Knit

**Pendant**  
Vol1 26  
**Floor & Table**  
Vol1 378

## Kontorno

**Pendant**  
Vol1 80  
**Wall**  
Vol2 278

## Lily

**Pendant**  
Vol1 14  
**Floor & Table**  
Vol1 372

## Line

**Ceiling**  
Vol2 76

## Match

**Pendant**  
Vol1 166

# Collections

## Mayfair

**Pendant**  
Vol1 194  
**Floor & Table**  
Vol1 394

## Mayfair Mini

**Floor & Table**  
Vol1 388

## Meridiano

**Outdoor**  
Vol2 450

## Musa

**Floor & Table**  
Vol1 454  
**Wall**  
Vol2 296

## North

**Pendant**  
Vol1 264  
**Floor & Table**  
Vol1 412  
**Wall**  
Vol2 330

## Offset

**Floor & Table**  
Vol1 460  
**Ceiling**  
Vol2 94  
**Wall**  
Vol2 348

## Origami

**Wall**  
Vol2 312  
**Outdoor**  
Vol2 388

## Out

**Floor & Table**  
Vol1 468  
**Outdoor**  
Vol2 378

## Palma

**Pendant**  
Vol1 170  
**Ceiling**  
Vol2 116  
**Wall**  
Vol2 256

## Palo Alto

**Outdoor**  
Vol2 394

## Pin

**Floor & Table**  
Vol1 418  
**Wall**  
Vol2 262

## Plusminus

**Plusminus**  
Vol1 271

## Plusminus Solo

**Floor & Table**  
Vol1 472  
**Ceiling**  
Vol2 120  
**Wall**  
Vol2 216

## Puck

**Ceiling**  
Vol2 192  
**Wall**  
Vol2 320

## Puck Wall Art

**Wall**  
Vol2 324

## Rhythm Horizontal

**Pendant**  
Vol1 182

## Rhythm Vertical

**Pendant**  
Vol1 188

## Set

**Wall**  
Vol2 274

## Skán

**Pendant**  
Vol1 116  
**Floor & Table**  
Vol1 434

## Slim

**Pendant**  
Vol1 212

## Spa

**Ceiling**  
Vol2 182  
**Wall**  
Vol2 232

## Sticks

**Pendant**  
Vol1 66  
**Wall**  
Vol2 340

## Sticks Solo

**Pendant**  
Vol1 384  
**Floor & Table**  
Vol1 384

## Structural

**Ceiling**  
Vol2 176  
**Wall**  
Vol2 268

## Suite

**Floor & Table**  
Vol1 430  
**Wall**  
Vol2 304

## Tempo

**Pendant**  
Vol1 234  
**Wall**  
Vol2 226

## Top

**Ceiling**  
Vol2 36  
**Wall**  
Vol2 210

## Tube

**Pendant**  
Vol1 106

## Tube Free

**Pendant**  
Vol1 100  
**Ceiling**  
Vol2 196

## Up

**Ceiling**  
Vol2 188

## Warm

**Pendant**  
Vol1 122  
**Floor & Table**  
Vol1 448

## Wind

**Pendant**  
Vol1 230  
**Outdoor**  
Vol2 422

## Wireflow

**Pendant**  
Vol1 126

## Wireflow Chandelier

**Pendant**  
Vol1 140

## Wireflow Free

**Pendant**  
Vol1 134

## Wireflow Lineal

**Pendant**  
Vol1 130

Ceiling

# Ceiling

|                      |                          |                     |
|----------------------|--------------------------|---------------------|
| Bigger<br>202        | Flat<br>68               | Puck<br>192         |
| Bind<br>128          | Funnel<br>172            | Spa<br>182          |
| Bind Solo<br>148     | Guise<br>168             | Structural<br>176   |
| Circle<br>18         | Line<br>76               | Top<br>36           |
| Circus<br>42         | Offset<br>94             | Tube<br>Free<br>196 |
| Circus<br>Solo<br>62 | Palma<br>116             | Up<br>188           |
| Duo<br>2             | Plusminus<br>Solo<br>120 |                     |
| Duo<br>Petra<br>12   |                          |                     |

# Duo



Design by Ramos & Bassols.

Duo brings natural warmth to a space. Its gently curved form encases a supple wood-finished interior, lending a soothing sensibility.









Articulated through simple volumes with a sculptural quality, Duo becomes a focal point without the need for suspension. Crafted in veined oak and matte-lacquered aluminum, its sleek shell and richly textured veneer yield an intriguing material contrast, complemented by a rich, diffuse downlight.





Vibia's general lighting, spot accent and downlight luminaires include the option of tunable white. Combining these zenithal tunable white lights with the rest of the diffused and indirect lighting effects of Vibia's portfolio, you can design the perfect scene for every moment and use.



**Tunable White (2200K - 4000K)**  
Tunable white lighting option allows for comprehensive temperature regulation depending on the atmosphere of every scene.

**Static White 2700K; 3500K**  
You can select the static white option that fits best with the desired ambience.

Contact Vibia Support Service at [vibia.com](http://vibia.com) for any kind of assistance or recommendation when designing an atmosphere of wellbeing, or if you require support with control system approach.

“We chose wood because it’s a natural and quality material. It lends warmth and at the same time contrasts with the surrounding meta”

Ramos & Bassols.



4870

Ø 47,5 cm



4872

Ø 78,5 cm



4878

Ø 70 cm



4880

Ø 70 cm



4874

Ø 35 cm



4876

Ø 35 cm



- 18 Graphite (ADAPTA RF9913WX)
- 58 Cream (RAL 7044)
- 93 White (RAL 9016)

Finish customization  
(Available options: Vibia colour palette)

Diffuser: PC- Polycarbonate  
Main Body: Aluminum  
Inner structure: Oak wood

**LED Colour Temperature**  
Static White  
2700 K; 3500 K  
Tunable White (2200 K - 4000 K)  
CRI>90

**Control**  
Analog: Push; 1-10V  
Digital: DALI-2; DALI-2 DT8  
Smart: Casambi

# Duo Petra



Design by Ramos & Bassols.

Duo Petra's slate veneer lends a timeless elegance to the collection. The ceiling lamp's gently curved form encases a velvety slate-finished interior for a sophisticated, natural aesthetic.





Simple volumes meet sculptural quality in Duo Petra, expressly designed for those lower-ceiling rooms where a pendant fitting is not suitable. It stands harmonious and sleek, its satinised diffuser radiating with a soft and general diffuse light.



Vibia's general lighting, spot accent and downlight luminaires include the option of tunable white. Combining these zenithal tunable white lights with the rest of the diffused and indirect lighting effects of Vibia's portfolio, you can design the perfect scene for every moment and use.



**Tunable White (2200K - 4000K)**  
Tunable white lighting option allows for comprehensive temperature regulation depending on the atmosphere of every scene.

**Static White 2700K; 3500K**  
You can select the static white option that fits best with the desired ambience.

Contact Vibia Support Service at [vibia.com](http://vibia.com) for any kind of assistance or recommendation when designing an atmosphere of wellbeing, or if you require support with control system approach.

Duo Petra's silky slate-lined interior provides a subtle contrast with its matte aluminum outer shell, a sober and modern aesthetic for an elegant interior style.



4871

Ø 47,5 cm



4873

Ø 78,5 cm



- 18 Graphite (ADAPTA RF9913WX)
- 58 Cream (RAL 7044)
- 93 White (RAL 9016)

Finish customization  
(Available options: Vibia colour palette)

Diffuser: PC- Polycarbonate  
Main Body: Aluminum  
Inner structure: Slate

**LED Colour Temperature**  
Static White  
2700 K; 3500 K  
Tunable White (2200 K - 4000 K)  
CRI>90

**Control**  
Analog: Push; 1-10V  
Digital: DALI-2; DALI-2 DT8  
Smart: Casambi

4875

Ø 35 cm



4877

Ø 35 cm



4879

Ø 70 cm



4881

Ø 70 cm



# Circle

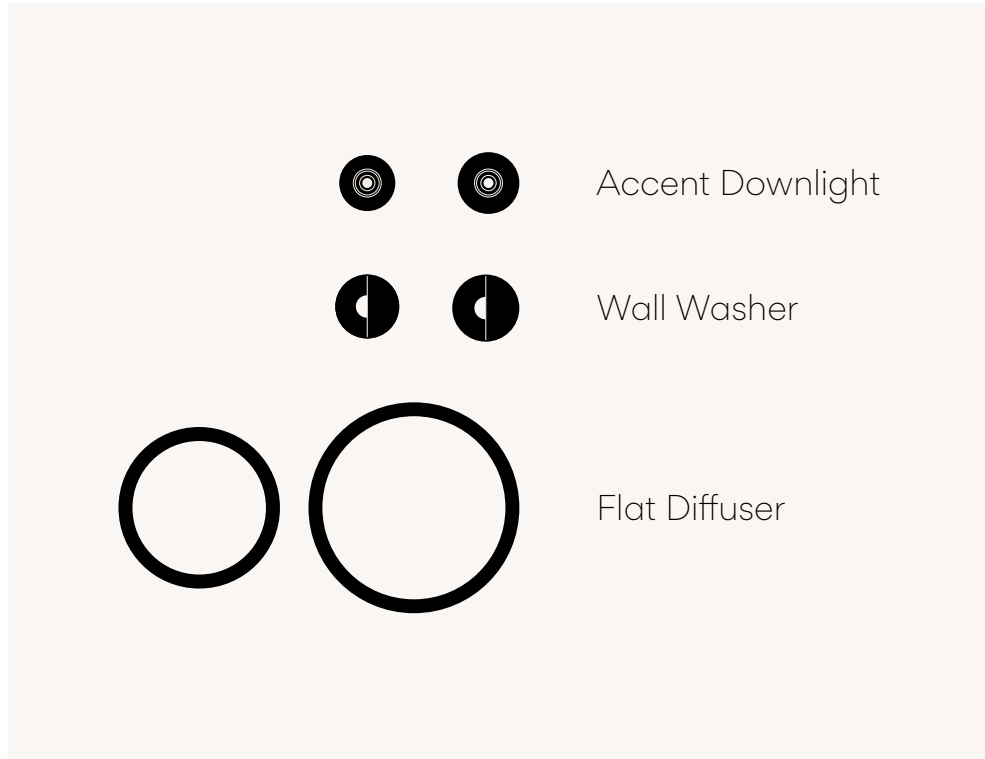

Combining accent, diffuse and general lighting effects with dynamic control and temperature regulation, Circle is a highly-functional complementary product designed to curate a nuanced ambience.



## Dynamic light

Dynamic light allows professionals to play with subtle degrees of intensity and colour temperature to recreate a subtle ambience for every scene within a lighting project

Designing an atmosphere of wellbeing is based on two main axes: **space** and **time**. The axis of time implies the concept of dynamic light.

Atmosphere design is intentional, depending on the **design of different scenes according to the specific use of a space** as it evolves throughout the day. Light is dynamic because ambience also depends **on the time of day** and on the influence of the natural light at every moment.



Throughout the day our circadian rhythms respond primarily to light, which regulates our sense of physical and mental wellbeing

## Comfortable environments

Vibia's spot accent, downlight and general lighting luminaires include the option of tunable white. Combining these zenithal tunable white lights with the rest of the diffused and indirect lighting effects of Vibia's portfolio, you can design the perfect scene for every moment and use.

Tunable lighting allows for comprehensive temperature regulation and intensity: colour temperature can be precisely tuned depending on the desired atmosphere for every scene.

### Static White

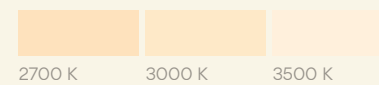

### Tunable White

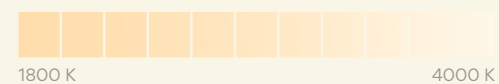

### Dim-To-Warm

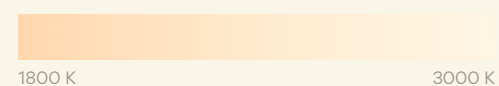

Contact Vibia Support Service at [vibia.com](http://vibia.com) for any kind of assistance or recommendation when designing an atmosphere of wellbeing, or if you require support with control system approach.



Scenographic lighting plays a critical role in retail design. Light enhances the expressive capacity of a space, creating visual hierarchy and ensuring a dialogue with customers. Different effects can be used to highlight certain products, draw the eye to particular areas and determine the general atmosphere, strengthening the shopping experience. Diffusers and wall-washers ensure comfortable background lighting, while accent downlights and spots create brilliance and contrast, lifting products out of their setting for dramatic effect.



## Accent Downlight - Colour

### COLOUR MODELS

A set of minimalist accent downlights in four versatile finishes attracts a relaxed gaze to a specific point of light. The option of a trimless profile offers seamless integration within the surrounding architecture.

- 11 Black (NCS S 8500-N)
- 23 Warm White (NCS S 0502-Y50R)
- 24 Beige M1 (NCS S 2005-Y50R)
- 37 Terra Red (NCS S 4040-Y70R)

Body: Aluminum  
Shade: PC- Polycarbonate  
Lens: PMMA

### LED Colour Temperature

Ø 6 cm; Ø 7 cm

Static White  
2700 K - 607 lm  
3000 K - 634 lm  
3500 K - 657 lm  
6,2W

Dim-To-Warm (1800 K - 3000 K)  
611 lm 5,8W

Tunable White (1800 K - 4000 K)  
308 lm - 504 lm 5,5W

Ø 10 cm; Ø 11 cm

Static White  
2700 K - 1256 lm  
3000 K - 1313 lm  
3500 K - 1360 lm  
12,4W

Dim-To-Warm (1800 K - 3000 K)  
1258 lm 11,6W

Tunable White (1800 K - 4000 K)  
571 lm - 895 lm 8,9W

CRI>90

### Control

Analog: On/Off; Push; 1-10V  
Digital: DALI-2; DALI-2 DT8  
Smart: Casambi

### Electrical connection

Built-in (Driver included)  
Remote

Visit [vibia.com](http://vibia.com) to group several pieces with just one electrical point

Updated detailed spec sheets on [vibia.com](http://vibia.com)



**3300** Narrow  
**3303** Medium  
**3306** Wide

Ø 7 cm



**3310** Narrow  
**3313** Medium  
**3316** Wide

Ø 6 cm

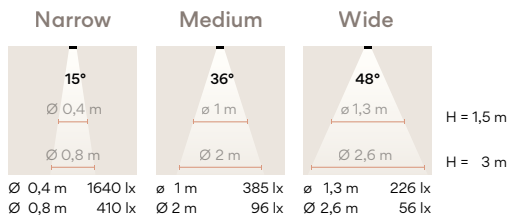

**3320** Narrow  
**3323** Medium  
**3326** Wide

Ø 11 cm



**3330** Narrow  
**3333** Medium  
**3336** Wide

Ø 10 cm

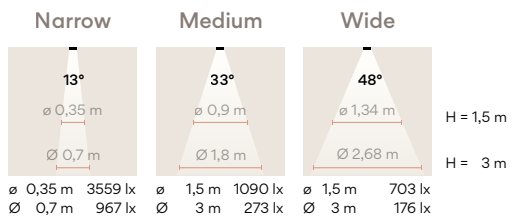



## Accent Downlight - Wood

### WOOD MODELS

The collection includes the option of a natural wood in White oak or Walnut. Reflected in its textured surface, warm light bathes the space, producing a rich and restorative atmosphere.

82 White oak

83 Walnut

Body: Aluminum  
Shade: Wood  
Lens: PMMA

### LED Colour Temperature

Ø 6 cm; Ø 7 cm

Static White  
2700 K - 607 lm  
3000 K - 634 lm  
3500 K - 657 lm  
6,2W

Dim-To-Warm (1800 K - 3000 K)  
611 lm 5,8W

Tunable White (1800 K - 4000 K)  
308 lm - 504 lm 5,5W

Ø 10 cm; Ø 11 cm

Static White  
2700 K - 1256 lm  
3000 K - 1313 lm  
3500 K - 1360 lm  
12,4W

Dim-To-Warm (1800 K - 3000 K)  
1258 lm 11,6W

Tunable White (1800 K - 4000 K)  
571 lm - 895 lm 8,9W

CRI>90

### Control

Analog: On/Off; Push; 1-10V  
Digital: DALI-2; DALI-2 DT8  
Smart: Casambi

### Electrical connection

Built-in (Driver included)  
Remote

Visit [vibia.com](http://vibia.com) to group several pieces with just one electrical point

Updated detailed spec sheets on [vibia.com](http://vibia.com)



TRIM



TRIMLESS

3300 Narrow  
3303 Medium  
3306 Wide

Ø 7 cm



3310 Narrow  
3313 Medium  
3316 Wide

Ø 6 cm

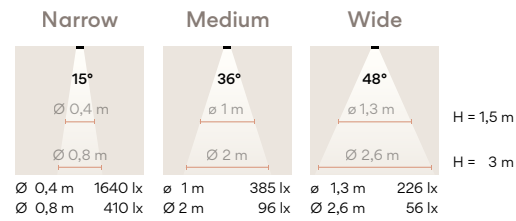

3320 Narrow  
3323 Medium  
3326 Wide

Ø 11 cm



3330 Narrow  
3333 Medium  
3336 Wide

Ø 10 cm

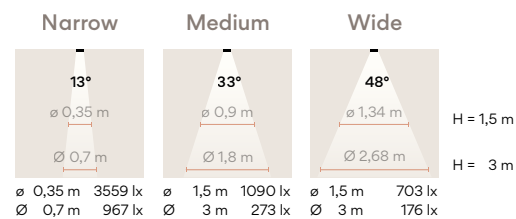

↑ IP20  
↓ IP40



Circle is designed to complement Vibia's wider product range. Its four contemporary tones and trim or trimless profile adapt to both high contrast and subtle design requirements. Especially suited to a natural, rounded aesthetic, the walnut and oak finishes combine well with Dots and Duo.



## Wall Washer

A Wall Washer option can be used to illuminate a vertical surface with uniform brightness, to accentuate an entrance or to highlight a specific feature such as a shelving unit. Light reflected from the matte surface of the wall makes the space appear brighter and provides soft, diffuse illumination.

- 11 Black (NCS S 8500-N)
- 23 Warm White (NCS S 0502-Y50R)
- 24 Beige M1 (NCS S 2005-Y50R)
- 37 Terra Red (NCS S 4040-Y70R)

Body: Aluminum  
Shade: PC- Polycarbonate  
Lens: PMMA

### LED Colour Temperature

Static White  
2700 K - 914 lm  
3000 K - 956 lm  
3500 K - 990 lm  
7,4W

Dim-To-Warm (1800 K - 3000 K)  
1258 lm 11,6W

Tunable White (1800 K - 4000 K)  
571 lm - 895 lm 8,9W

CRI>90

### Control

Analog: On/ Off; Push; 1-10V  
Digital: DALI-2; DALI-2 DT8  
Smart: Casambi

### Electrical connection

Built-in (Driver included)  
Remote

Visit [vibia.com](http://vibia.com) to group several pieces with just one electrical point

Updated detailed spec sheets on [vibia.com](http://vibia.com)



## Flat Diffuser

Featuring a translucent cover to control the brightness, the Flat Diffuser model provides soft, general lighting for a comfortable atmosphere or effective transitioning between different spaces.

- 11 Black (NCS S 8500-N)
- 23 Warm White (NCS S 0502-Y50R)
- 24 Beige M1 (NCS S 2005-Y50R)
- 37 Terra Red (NCS S 4040-Y70R)

Body: Aluminum  
Shade: PC- Polycarbonate  
Diffuser: PC- Polycarbonate

### LED Colour Temperature

Static White  
2700 K; 3000 K; 3500 K  
Tunable White (2200 K - 4000 K)  
CRI>90

### Control

Analog: On/Off; Push  
Digital: DALI-2; DALI-2 DT8  
Smart: Casambi

### Electrical connection

Built-in (Driver included)



**3360**

Ø 36 cm



**3363**

Ø 47 cm





# Top



Design by Ramos & Bassols.

Soft, spherical shapes and a warm luminescence characterize the Top collection. Its glowing epicenter is encircled by a larger ring, framing the light within its pure geometry.



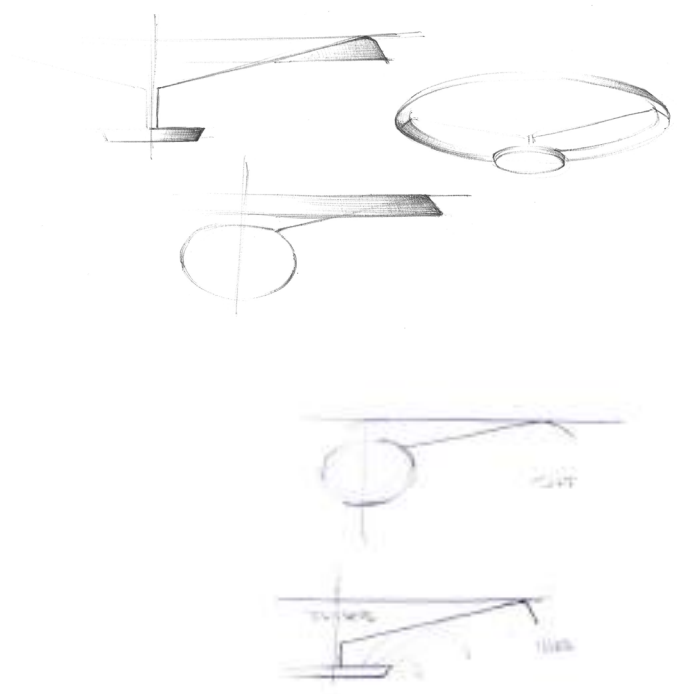

A contemporary take on the traditional rosette motif, Top is defined by a pair of concentric circles that combine to produce a halo of ambient, indirect light.





1160

Ø 60 cm

1170

Ø 90 cm

Top distills the timeless rosette down to its essence. A pair of simple circles creates a pulsing nucleus of LED-powered light overhead. The smaller illuminated sphere projects light outwards towards the larger one, creating a halo of even, indirect light and generating a soothing atmosphere.

- 10 White (NCS S 0300-N)
- 36 Soft Pink (NCS S 1010-Y50R)
- 40 Blue L1 (NCS S 3010-B)
- 47 Green L1 (NCS S 4005-G80Y)

Body: Aluminum  
 Ref. 1170  
 Diffuser: Triplex Opal Glass

**LED Colour Temperature**

2700 K; 3500 K  
 CRI>90

**Control**

Analog: Push; 1-10V;  
 Digital: DALI-2  
 Smart: Casambi



# Circus

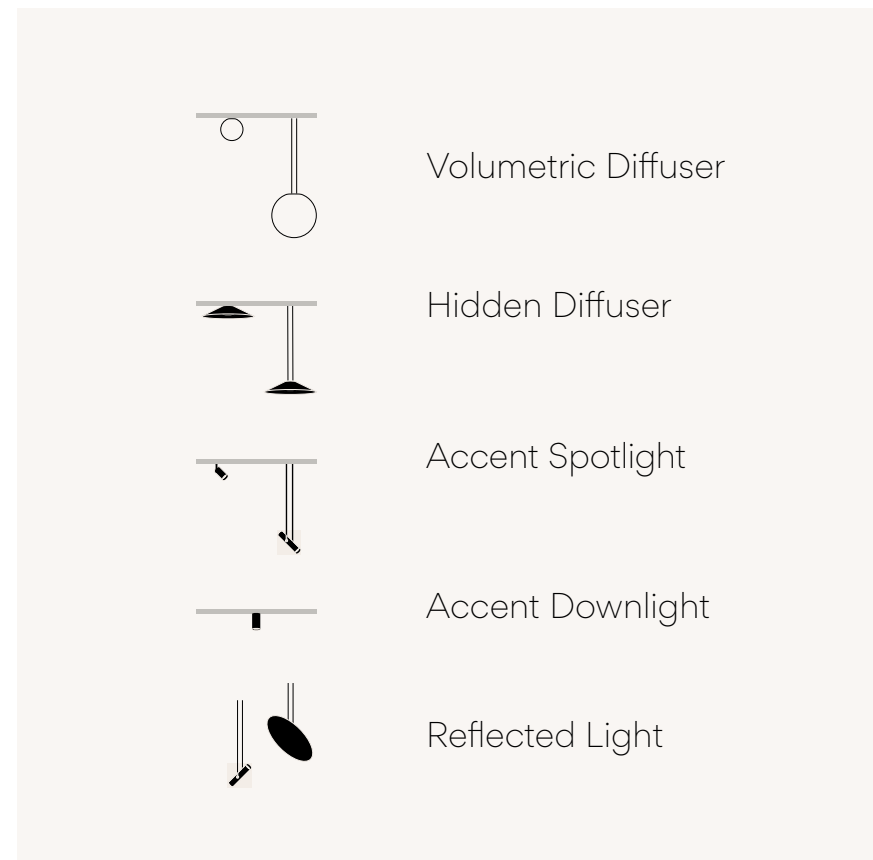

Design by Antoni Arola.

A creative toolkit full of possibilities to explore and enjoy, Circus offers total freedom of composition, multiple components and a myriad of diffuse, accented and reflected lighting effects. Inspired by the tension and dynamics of a trapeze act, the collection is defined by its minimalist structure and signature conductive bar, delicately balanced by opposing elements to create a joyful festival of light.







Often considered the heart of any home, the kitchen serves as a space for preparing food, for cooking, and for eating.

But it also transcends its functional purpose.

The act of eating creates an opportunity for people to gather together. It is a social space, a meeting point for the entire family, and a manifestation of cultural traditions.

A good kitchen should combine functionality with aesthetics, embracing the many different uses we have for our kitchens today. Circus allows the designer to play with different lighting effects, introducing a variety of fixtures that can be built into the conductive bar, suspended from a track or hung directly from the surface of the ceiling. Go to [vibia.com](http://vibia.com) to find the best solution for your project.

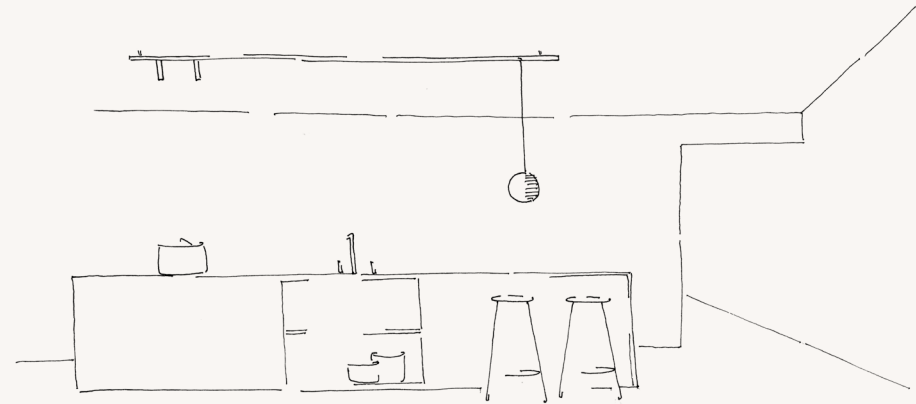



Spots and downlights can be used to play with contrasts, define functional areas or highlight key aspects of a space. Thanks to their capacity for adaptation, rotation, and different degrees of lens aperture, Circus spotlights accommodate different functions. The narrower the beam, the more specular the light becomes, creating dynamic visual hierarchies with darker shadows and intense highlights.

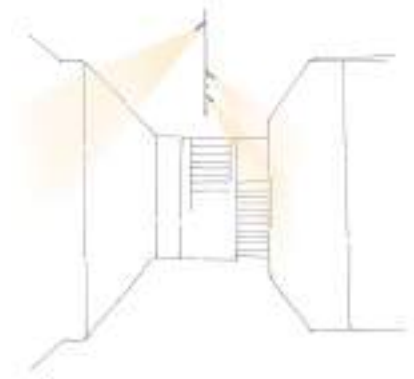

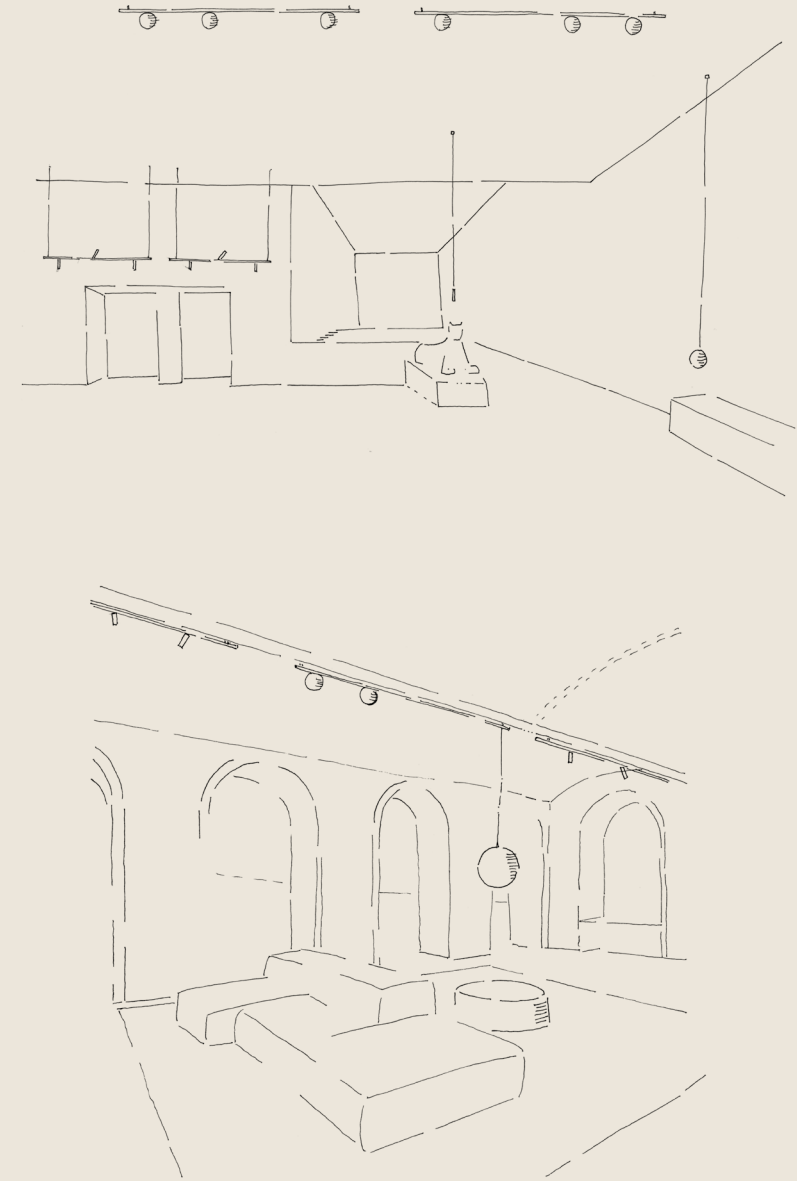







The bar amplifies the possibilities for shaping a space by conducting electricity and transporting light to wherever it is needed, turning the professional into a composer of atmospheres.

The track is available in two sizes and the electrical connection piece is concealed to adapt to all kinds of ceilings. A choice of two versatile finishes ensures the collection adapts to any interior style.

- 11 Black (NCS S 8500-N)
- 24 Beige M1 (NCS S 2005-Y50R)

Electrical connection options



Surface Built-in Remote

Ceiling Tracks

A352 210 cm



A355 300 cm

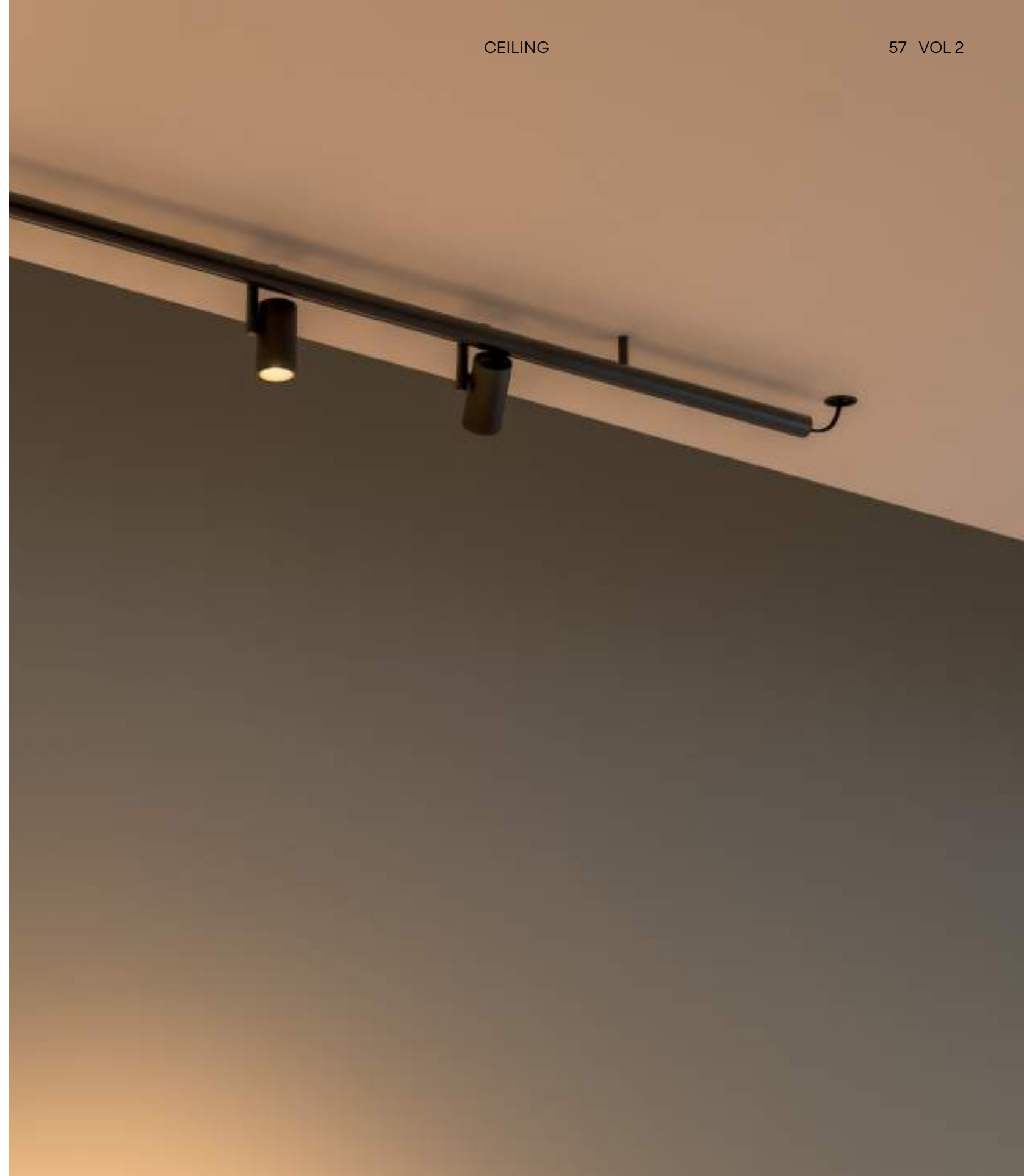
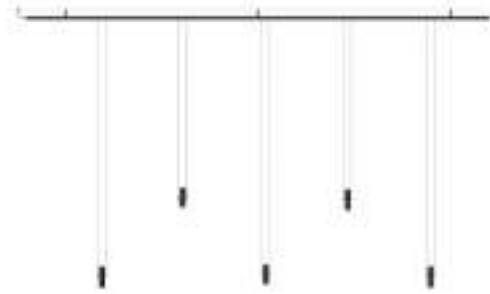

Developed both vertically and horizontally, the system combines spots, reflective discs and a range of striking diffusers to create a perfect synthesis of atmospheres. With a traditional light rail the connection is visible from below, but with Circus, the luminaires are connected to the bar from above and sealed with cover, significantly enhancing the aesthetic purity of the design.

- 11 Black (NCS S 8500-N)
- 24 Beige M1 (NCS S 2005-Y50R)

**Volumetric Diffuser**

Diffuser: PE- Polyethylene

**Hidden Diffuser**

Shade: Aluminum

Diffuser: PC- Polycarbonate

**Spots / Downlight**

Body: Aluminum

Lens: PMMA

**Pendant Spot**

Body: Zinc Alloy

Lens: PMMA



**LED Colour Temperature**

Volumetric Diffuser / Hidden Diffuser

Static White

2700 K; 3000 K; 3500 K

Tunable White (1800 K- 4000 K)

Tunable Red (Red - 2700 K)

**Spots / Downlight**

Static White

2700 K - 680 lm

3000 K - 711 lm

3500 K - 737 lm

7,2W

Only ref. 0136, 0137, 0141,

0142, 0152 and 0153

Tunable White (1800 K - 4000 K)

Smart (P2P)

308 lm - 504 lm 5,5W

Only ref. 0136, 0141 and 0152

Tunable Red (Red - 2700 K)

Smart (P2P)

155 lm - 581 lm 7W

CRI>90

**Control**

Digital: DALI-2 (P2P)

Smart: Casambi (simultaneous line);

Casambi (P2P); ProtoPixel\* (P2P)

\*ProtoPixel products are compatible with all other DALI-2 products via a designated gateway (please consult us)

Updated detailed spec sheets on [vibia.com](http://vibia.com)

Volumetric Diffuser

PENDANT

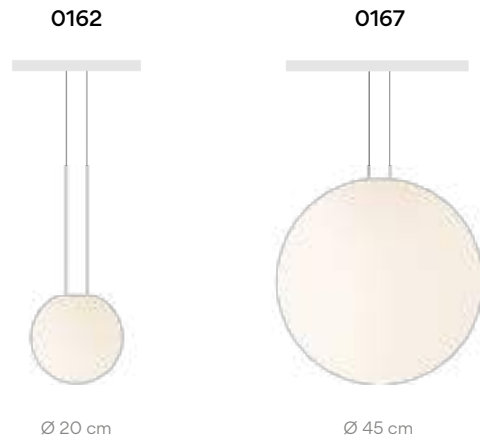

DIRECT TO TRACK



Hidden Diffuser

PENDANT

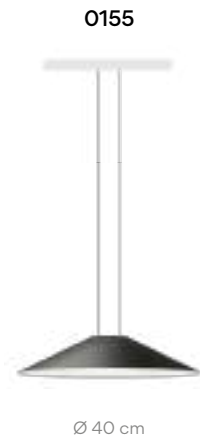

DIRECT TO TRACK



Accent Spotlight

PENDANT

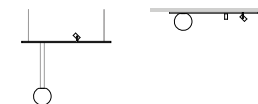

Pg 32 VOL 1 Pg 42 VOL 2

SIDE-SPOTS

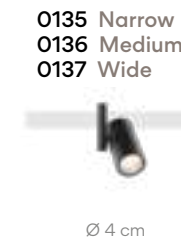

Accent Downlight

DOWNLIGHTS

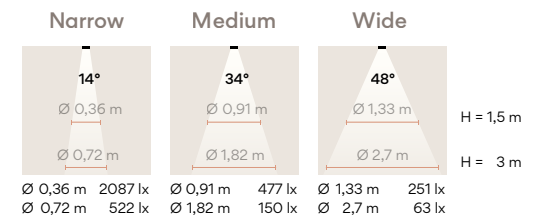

Suspended from the ceiling and positioned at any angle, a range of reflector discs reflect diffuse light from a spot angled towards them. Lustrous and ethereal, they cast a spherical shadow on the adjacent surface like a lunar eclipse.

● 11 Black  
(Bottom face: White / Top face: Black)



### Reflected Light

LIGHT REFLECTOR

A146



Ø 40 cm L 9 m

A147



Ø 60 cm L 9 m

## Dynamic light

Dynamic light allows professionals to play with subtle degrees of intensity and colour temperature to recreate a subtle ambience for every scene within a lighting project

## A source of emotion

Designing an atmosphere of wellbeing is based on two main axes: **space** and **time**. The axis of time implies the concept of dynamic light.

Atmosphere design is intentional, depending on the **design of different scenes according to the specific use of a space** as it evolves throughout the day. Light is dynamic because ambience also depends **on the time of day** and on the influence of the natural light at every moment.

Throughout the day our circadian rhythms respond primarily to light, which regulates our sense of physical and mental wellbeing.

Vibia's approach to coloured light invites the use of colour and intensity to create and experience different atmospheres, making them as natural and subtle as possible.

Colour is a source of emotion, it can instantly set a mood, convey a feeling or generate a sense of wellbeing.



## Static, tunable white and tunable red

Circus product options offer a range of static white in three different temperatures as well as the option of tunable white. Tunable lighting allows for comprehensive temperature regulation: colour temperature can be precisely tuned depending on the desired atmosphere for every scene.

The **tunable red** option allows you to glide from red to white, exploring a range of relaxing and cosy effects. Tunable white lighting option allows for comprehensive temperature regulation depending on the atmosphere of every scene.

### Static White

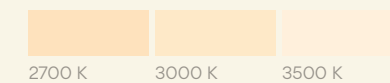

### Tunable White

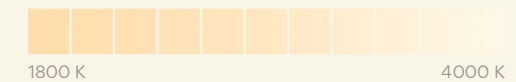

### Tunable Red



Contact Vibia Support Service at [vibia.com](http://vibia.com) for any kind of assistance or recommendation when designing an atmosphere of wellbeing, or if you require support with control system approach.

# Circus Solo

Accent Spotlight

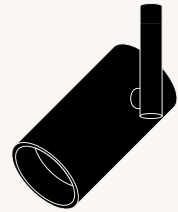

Circus Solo features a remote or built in accent spot that can be used to play with contrasts, define functional areas or highlight key aspects of a space. By mixing accent, reflected and diffuse lighting, the Circus system allows professionals to experiment with light density, creating multiple scenes within a single space.





## Accent Spotlight

- 11 Black (NCS S 8500-N)
- 24 Beige M1 (NCS S 2005-Y50R)

Body: Aluminum  
 Lens: PMMA  
 Snoot: PC- Polycarbonate

## LED Colour Temperature

Static White  
 2700 K - 680 lm  
 3000 K - 711 lm  
 3500 K - 737 lm  
 7,2W

Only ref. 0172, 0173  
 Tunable White (1800 K - 4000 K)  
 Smart  
 308 lm - 504 lm 5,5W

Only ref. 0172  
 Tunable Red (Red - 2700 K)  
 Smart  
 155 lm - 581 lm 7W

CRI>90

## Control

Analogue: On/ Off; Push  
 Digital: DALI-2\*  
 Smart: Casambi

\*DALI-2 products are compatible (via a designated gateway) with all ProtoPixel dynamic-light solution products.

## Electrical connection options



Remote    Built-in  
 Micro

Driver included

Visit [vibia.com](http://vibia.com) to group several pieces with just one electrical point

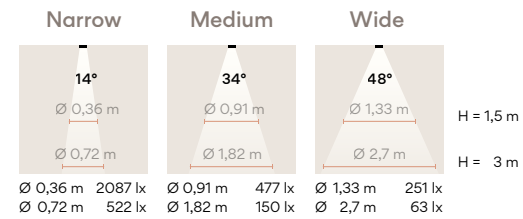

## SPOTS (REMOTE / BUILT-IN)

Static,  
tunable white  
and tunable red

Circus product options offer a range of static white in three different temperatures as well as the option of tunable white. Tunable lighting allows for comprehensive temperature regulation: colour temperature can be precisely tuned depending on the desired atmosphere for every scene.

The **tunable red** option allows you to glide from red to white, exploring a range of relaxing and cosy effects. Tunable white lighting option allows for comprehensive temperature regulation depending on the atmosphere of every scene.

## Static White

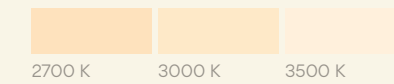

## Tunable White

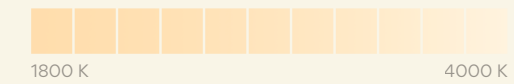

## Tunable Red

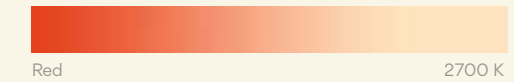

Contact Vibia Support Service at [vibia.com](http://vibia.com) for any kind of assistance or recommendation when designing an atmosphere of wellbeing, or if you require support with control system approach.



# Flat



Design by Ichiro Iwasaki.

A study in geometry, the Flat collection features distinctive, disc-shaped diffusers that form horizontal planes of light, infusing a space with pools of soft illumination.

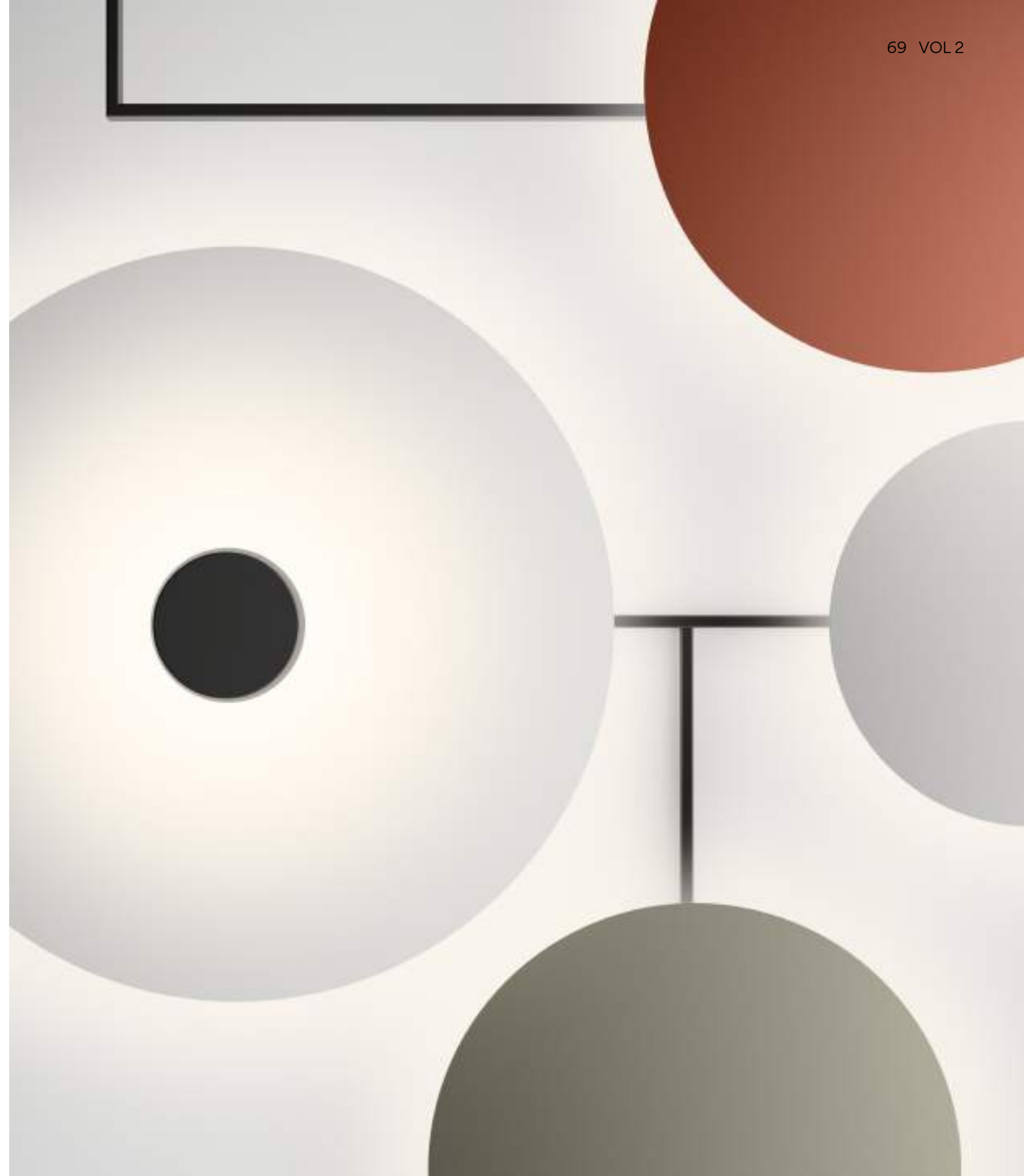





"A reflector lamp collection that connects a floating light source with a linear structure. Minimal reflector discs and linear structure provide simple and powerful universality like alphabets and musical scores".

Ichiro Iwasaki

5920  
Ø 40 cm



5915  
Ø 55 cm



5926  
Ø 90 cm



\* 5922  
178 x 149 cm



\* 5905  
101 x 88 cm

\* 5924  
186 x 149 cm

\* 5910  
106 x 90 cm



Ref. 5922

- 10 White (NCS S 0300-N)
- ● 71 White, Green L1, Off-White (NCS S 0300-N, NCS S 4005-G80Y, NCS S 1000-N)

Ref. 5924

- 10 White (NCS S 0300-N)
- ● 72 White, Green L1 (NCS S 0300-N, NCS S 4005-G80Y)
- ● 73 White, Off-White (NCS S 0300-N, NCS S 1000-N)

Ref. 5926, 5915

- 10 White (NCS S 0300-N)

Ref. 5920

- 10 White (NCS S 0300-N)
- 13 Off-White (NCS S 1000-N)
- 47 Green L1 (NCS S 4005-G80Y)

Shade: Aliminum. Diffuser: PC- Polycarbonate  
Structures: Steel. Canopy: Aluminum

LED Colour Temperature

2700 K; 3500 K  
CRI>90

Control

Ref. 5920, 5926  
Analog: Push; 1-10V  
Digital: DALI-2  
Ref. 5922, 5924  
Analog: Push; 1-10V  
Digital: DALI-2  
Smart: Casambi

\* One electrical connection point

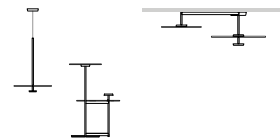

Pg 94/405 VOL 1 Pg 68 VOL 2



# Line



Line consists of a series of simple linear luminaires, each with a distinct lighting effect. Integrating dynamic control and subtle gradients in intensity, tone and colour, the collection complements Vibia's wider product range to curate a subtle atmosphere.

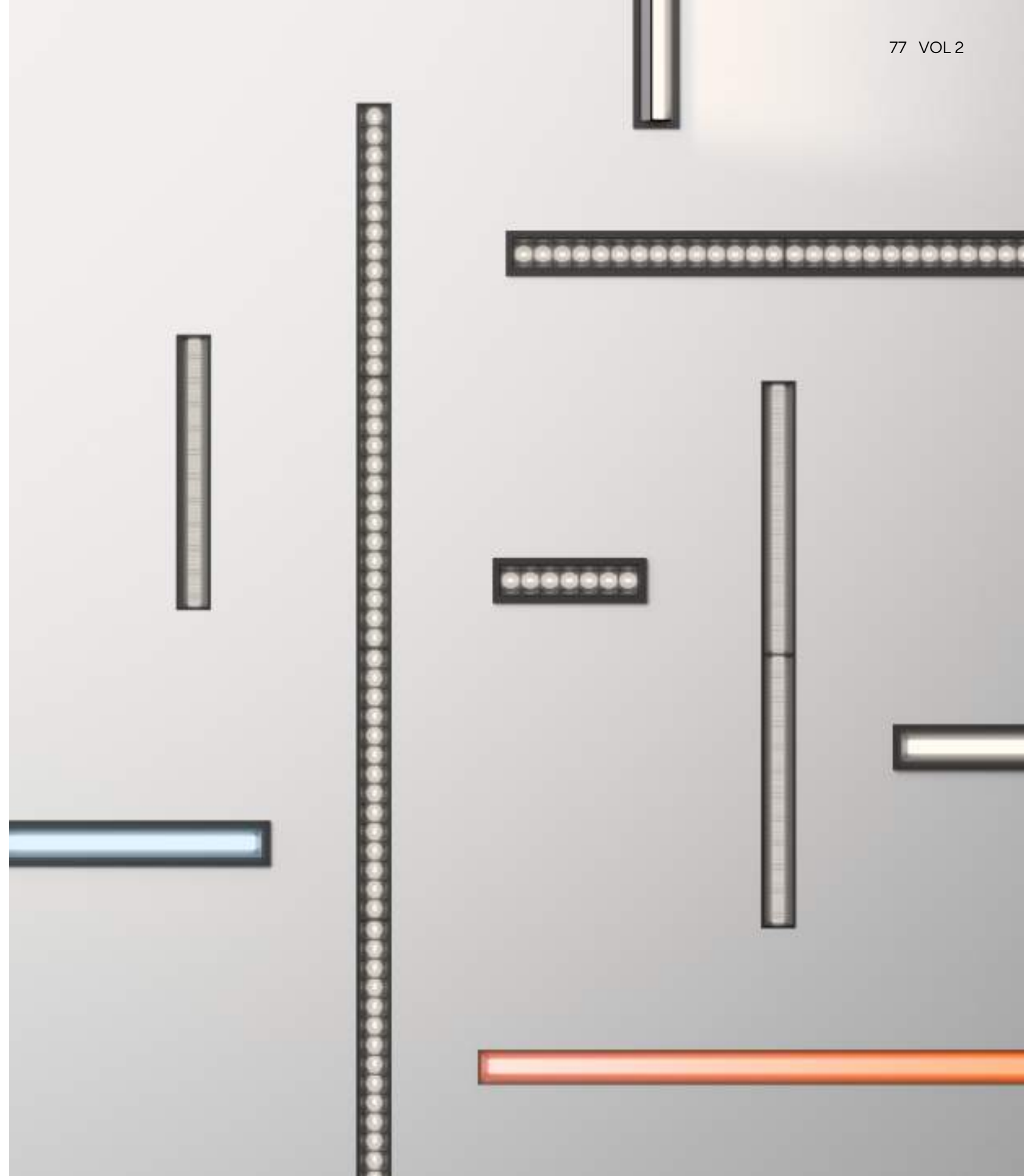

## Dynamic light

Dynamic light allows professionals to play with subtle degrees of intensity and colour temperature to recreate a subtle ambience for every scene within a lighting project



Throughout the day our circadian rhythms respond primarily to light, which regulates our sense of physical and mental wellbeing

## Comfortable environments

Vibia's spot accent, downlight and general lighting luminaires include the option of tunable white. Combining these zenithal tunable white lights with the rest of the diffused and indirect lighting effects of Vibia's portfolio, you can design the perfect scene for every moment and use.

Tunable lighting allows for comprehensive temperature regulation and intensity: colour temperature can be precisely tuned depending on the desired atmosphere for every scene.

### Static White



### Tunable White

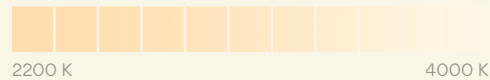

Contact Vibia Support Service at [vibia.com](http://vibia.com) for any kind of assistance or recommendation when designing an atmosphere of wellbeing, or if you require support with control system approach.



## High Comfort Diffuser

Available in various lengths, with and without trim, and in two modest finishes, Line guarantees subtle integration within the surrounding architecture. The homogeneous quality of light from the High Comfort diffuser is designed to create a peaceful, rich and relaxing ambience, ensuring smooth lighting across the surface of the ceiling.

- 11 Black (NCS S 8500-N)
- 23 Warm White (NCS S 0502-Y50R)

Body: Aluminum / PC- Polycarbonate  
 Shade: PC- Polycarbonate  
 Diffuser: PE- Polyethylene  
 Trimless frame: Aluminum

### LED Colour Temperature

Static White  
 2700 K; 3000 K; 3500 K  
 Tunable White (2200 K - 4000 K)

CRI>90

UGR<21

### Control

Analog: On/ Off; Push; 1-10V  
 Digital: DALI-2; DALI-2 DT8  
 Smart: Casambi

### Electrical connection

Built-in (Driver included)

Visit [vibia.com](http://vibia.com) to group several pieces with just one electrical point

Updated detailed spec sheets on [vibia.com](http://vibia.com)

TRIMLESS



TRIM



3503 Trimless 13 x 3 cm



3500 Trim 14 x 4 cm



3508 Trimless 27 x 3 cm



3505 Trim 28 x 4 cm



3513 Trimless 53 x 3 cm



3510 Trim 54 x 4 cm



3518 Trimless 102 x 3 cm



3515 Trim 103 x 4 cm





A well-illuminated work space with clearly defined areas of activity can enhance productivity, concentration and dialogue, strengthening the work-day experience and generating a collective sense of well-being. General lighting sets the tone, washing a space with comfortable uniform illumination that brightens the entire area. Task lighting, on the other hand, provides the right kind of light for a specific use. The nature and intensity of the light is determined by the intended purpose, defining clear “activity zones” within a space.

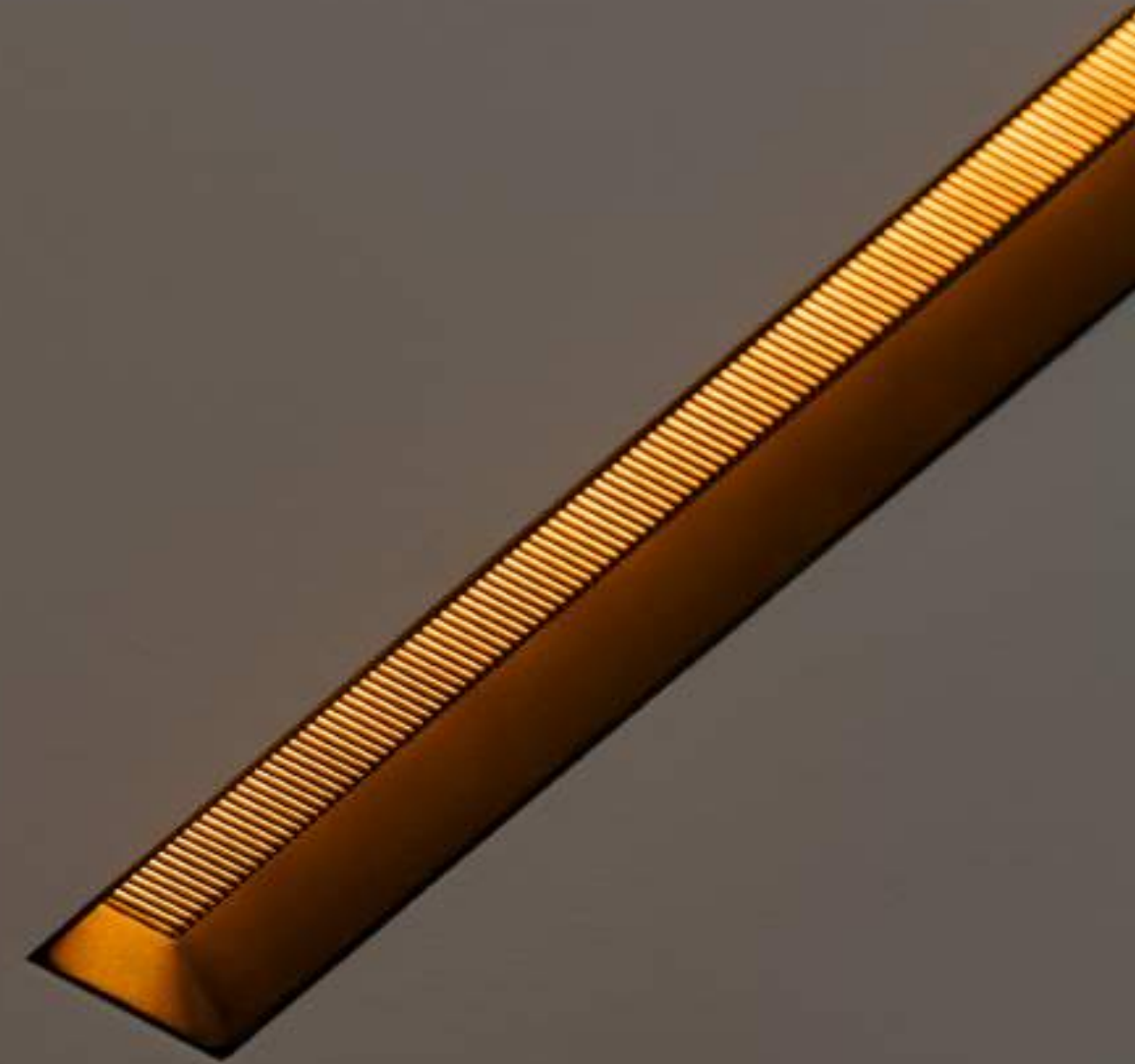



## Flat Diffuser

Featuring a translucent cover to control the brightness, the Flat Diffuser creates a comfortable atmosphere by casting a pleasant, uniform light. Designers can experiment with composition, incorporating various lengths for a distinctly linear look.

- 11 Black (NCS S 8500-N)
- 23 Warm White (NCS S 0502-Y50R)

Body: Aluminum  
Trimless frame: Aluminum  
Diffuser: PC- Polycarbonate

**LED Colour Temperature**

2700 K; 3000 K; 3500 K  
Tunable White (2200 K - 4000 K)  
CRI>90

**Control**

Analog: On/ Off; Push; 1-10V  
Digital: DALI-2\*; DALI-2 DT8\*  
Smart: Casambi

\*DALI-2 products are compatible (via a designated gateway) with all ProtoPixel dynamic-light solution products.

**Electrical connection**

Built-in (Driver included)

Updated detailed spec sheets on [vibia.com](http://vibia.com)

## TRIMLESS

## TRIM



**3533 Trimless** 52 x 3 cm 

**3530 Trim** 53 x 4 cm 

**3538 Trimless** 102 x 3 cm 

**3535 Trim** 103 x 4 cm 

**3543 Trimless** 202 x 3 cm 

**3540 Trim** 203 x 4 cm 



# High Efficiency Low Glare

Respecting our natural circadian rhythms, the Linear Low-Glare High Efficiency option eliminates unwanted glare, providing soft, general lighting for a comfortable interior or subtle transition between different scenes.

TRIMLESS

TRIM

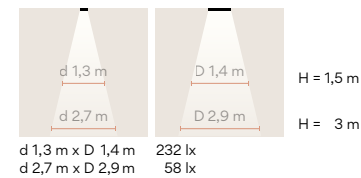

**3553 Trimless** 13 x 3 cm

**3550 Trim** 14 x 4 cm

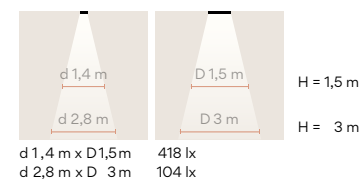

**3558 Trimless** 26 x 3 cm

**3555 Trim** 27 x 4 cm

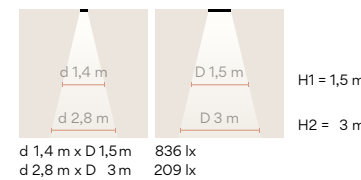

**3563 Trimless** 51 x 3 cm

**3560 Trim** 53 x 4 cm

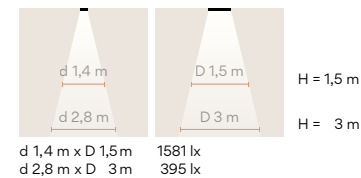

**3568 Trimless** 102 x 3 cm

**3565 Trim** 104 x 4 cm



- 11 Black (NCS S 8500-N)
- 23 Warm White (NCS S 0502-Y50R)

Body: Aluminum / PC- Polycarbonate  
 Shade: PC- Polycarbonate  
 Diffuser: PE- Polyethylene  
 Trimless frame: Aluminum

### LED Colour Temperature

13 cm; 14 cm  
 Static White  
 2700 K - 897 lm  
 3000 K - 928 lm  
 3500 K - 960 lm  
 7,4W  
 Tunable White (2200 K - 4000 K)  
 664 lm - 898 lm 7,2W

26 cm; 27 cm  
 Static White  
 2700 K - 1674 lm  
 3000 K - 1733 lm  
 3500 K - 1791 lm  
 13,7W  
 Tunable White (2200 K - 4000 K)  
 1262 lm - 1707 lm 13,7W

51 cm; 53 cm  
 Static White  
 2700 K - 3348 lm  
 3000 K - 3466 lm  
 3500 K - 3582 lm  
 27,4W  
 Tunable White (2200 K - 4000 K)  
 2524 lm - 3414 lm 27,4W

102 cm; 104 cm  
 Static White  
 2700 K - 6696 lm  
 3000 K - 6932 lm  
 3500 K - 7164 lm  
 54,8W  
 Tunable White (2200 K - 4000 K)  
 5048 lm - 6828 lm 54,7W

CRI>90  
 UGR<18

**Control**  
 Analog: On/ Off; Push; 1-10V  
 Digital: DALI-2; DALI-2 DT8  
 Smart: Casambi

**Electrical connection**  
 Built-in (Driver included)

Updated detailed spec sheets on [vibia.com](http://vibia.com)

Visit [vibia.com](http://vibia.com) to group several pieces with just one electrical point

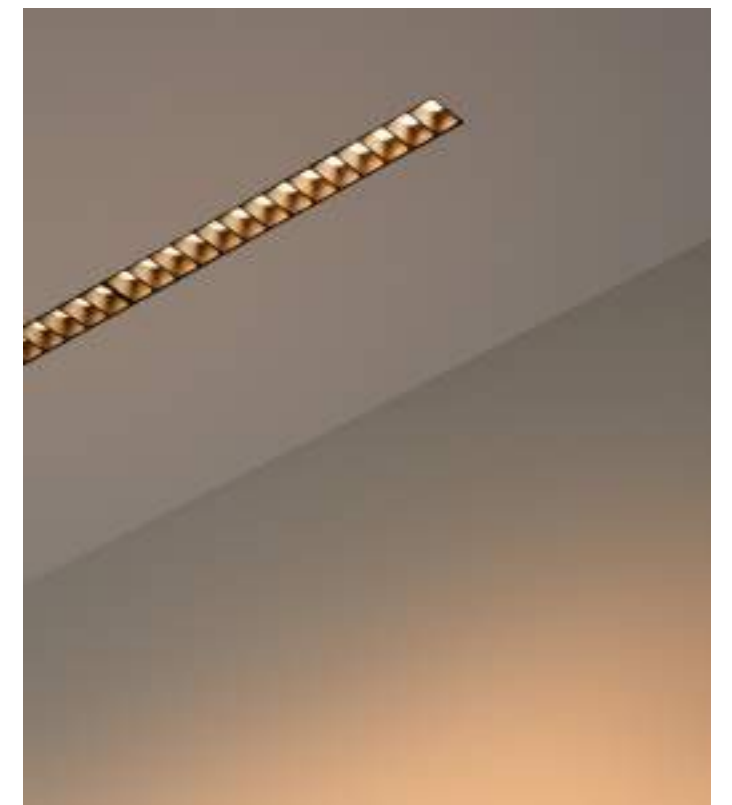

# Wall Washer

A Wall Washer can be selected to illuminate a vertical surface with uniform brightness, accentuate an entrance or highlight a specific feature. Light reflected from the matte surface of the wall makes the space appear brighter and provides soft, diffuse illumination.

TRIMLESS

TRIM

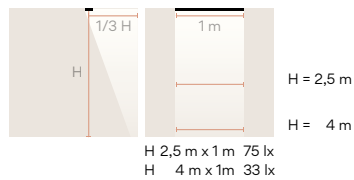
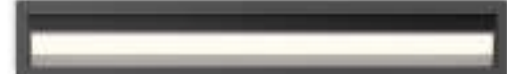

**3578 Trimless**

26 x 3 cm



H = 2,5 m

**3575 Trim**

27 x 4 cm



H = 4 m

H 2,5 m x 1 m 75 lx  
H 4 m x 1 m 33 lx

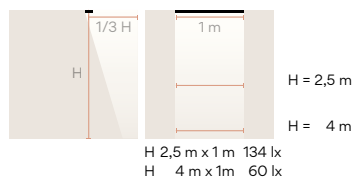

**3583 Trimless**

51 x 3 cm



H = 2,5 m

**3580 Trim**

53 x 4 cm



H = 4 m

H 2,5 m x 1 m 134 lx  
H 4 m x 1 m 60 lx

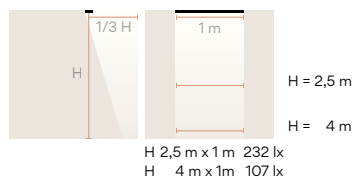

**3588 Trimless**

102 x 3 cm



H = 2,5 m

**3585 Trim**

104 x 7 cm



H 2,5 m x 1 m 232 lx  
H 4 m x 1 m 107 lx

- 11 Black (NCS S 8500-N)
- 23 Warm White (NCS S 0502-Y50R)

Body: Aluminum / PC- Polycarbonate  
Shade: PC- Polycarbonate  
Diffuser: PE- Polyethylene  
Trimless frame: Aluminum

### LED Colour Temperature

26 cm; 27 cm

Static White  
2700 K - 1392 lm  
3000 K - 1430 lm  
3500 K - 1455 lm  
13,3W

Tunable White (2200 K - 4000 K)  
764 lm - 849 lm 11,5W

51 cm; 53 cm

Static White  
2700 K - 2784 lm  
3000 K - 2860 lm  
3500 K - 2911 lm  
26,6W

Tunable White (2200 K - 4000 K)  
1528 lm - 1698 lm 23W

102 cm; 104 cm

Static White  
2700 K - 5568 lm  
3000 K - 5721 lm  
3500 K - 5822 lm  
53,2W

Tunable White (2200 K - 4000 K)  
3056 lm - 3396lm 46W

CRI>90

### Control

Analog: On/ Off; Push; 1-10V  
Digital: DALI-2; DALI-2 DT8  
Smart: Casambi

### Electrical connection

Built-in (Driver included)

Visit [vibia.com](http://vibia.com) to group several pieces with just one electrical point

Updated detailed spec sheets on [vibia.com](http://vibia.com)



**Tunable White** lighting allows for comprehensive temperature regulation. By controlling the individual LEDs, you can precisely tune the temperature from warm to cool white, depending on the desired atmosphere.

### Tunable White

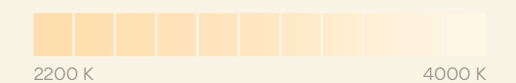

## Colour Mood Grazer

Natural light is never mono-tonal. The Colour Mood Grazer is an elegant solution where either Tunable White or Infinite Colour regulation is desired. Infinite Colour incorporates six unique hues, available both as static colours or gradients, each spectrum unique to Vibia and designed to transmit a particular mood. The installer plays a fundamental role in programming the appropriate lighting mode for the space and its desired use.

- 11 Black (NCS S 8500-N)
- 23 Warm White (NCS S 0502-Y50R)

Body: Aluminum / PC- Polycarbonate  
 Shade: PC- Polycarbonate  
 Diffuser: Polyethylene  
 Trimless frame: Aluminum



**LED Colour Temperature**  
 Infinite Colour (TW + RGB)  
 CRI>90

**Control**  
 Smart: ProtoPixel\*  
 \*ProtoPixel products are compatible with all other DALI-2 products via a designated gateway (please consult us)

**Electrical connection**  
 Built-in (Driver included)

Updated detailed spec sheets on [vibia.com](http://vibia.com)

TRIMLESS

TRIM



**3608 Trimless** 100 x 3 cm 

**3605 Trim** 103 x 4 cm 

**3613 Trimless** 202 x 3 cm 

**3610 Trim** 203 x 4 cm 

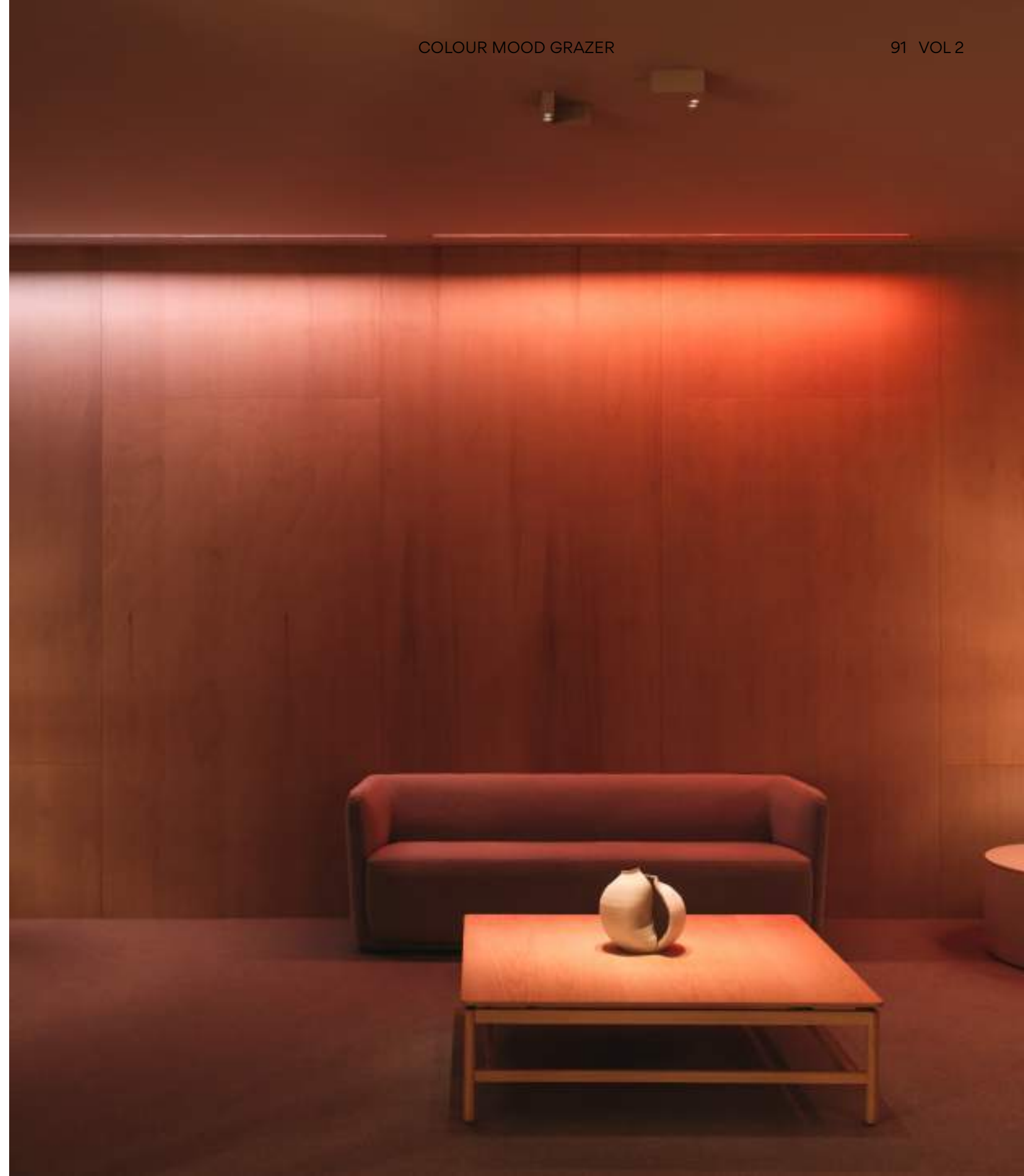

## A source of emotion

Colour is a source of emotion it can instantly set a mood, convey a feeling or generate a sense of wellbeing

Vibia's approach to coloured light invites the use of colour and gradients to create and experience different atmospheres, making them as natural and subtle as possible. Natural light is never mono-tonal. Gradients come in infinite colours.



## Vibia Chromatica colours of light

### Static White

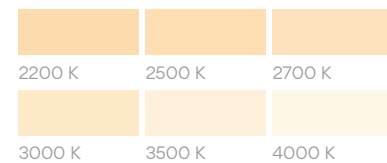



You can integrate your lighting selection into the control system for specific scene design and activate it also using the Vibia App.

### Colour Moods

- 

**Still** - A pale and thin green light, inspired by the very first rays of morning sun
- 

**Vivid** - A vibrating blue with a hint of pale yellow for a feeling of liveliness
- 

**Delicate** - A warm and glowing orange-yellow hue, reminiscent of afternoon sun spilling through the window
- 

**Cozy** - Bringing a glowing warmth, this orange-red hue contains darker, moodier undertones
- 

**Intense** - A powerful and bold red. Not just a striking colour, but deep and nuanced
- 

**Illusive** - An alluring and intriguing blue light that lends an energised, almost magical feel to a space

Contact Vibia Support Service at [vibia.com](http://vibia.com) for any kind of assistance or recommendation when designing an atmosphere of wellbeing, or if you require support with control system approach.

## Still colour mood

Light and airy, with a softness that suggests the quiet moment before a new beginning. A pale and thin green light, inspired by the very first rays of morning light. The gradient has a hint of blue to it.

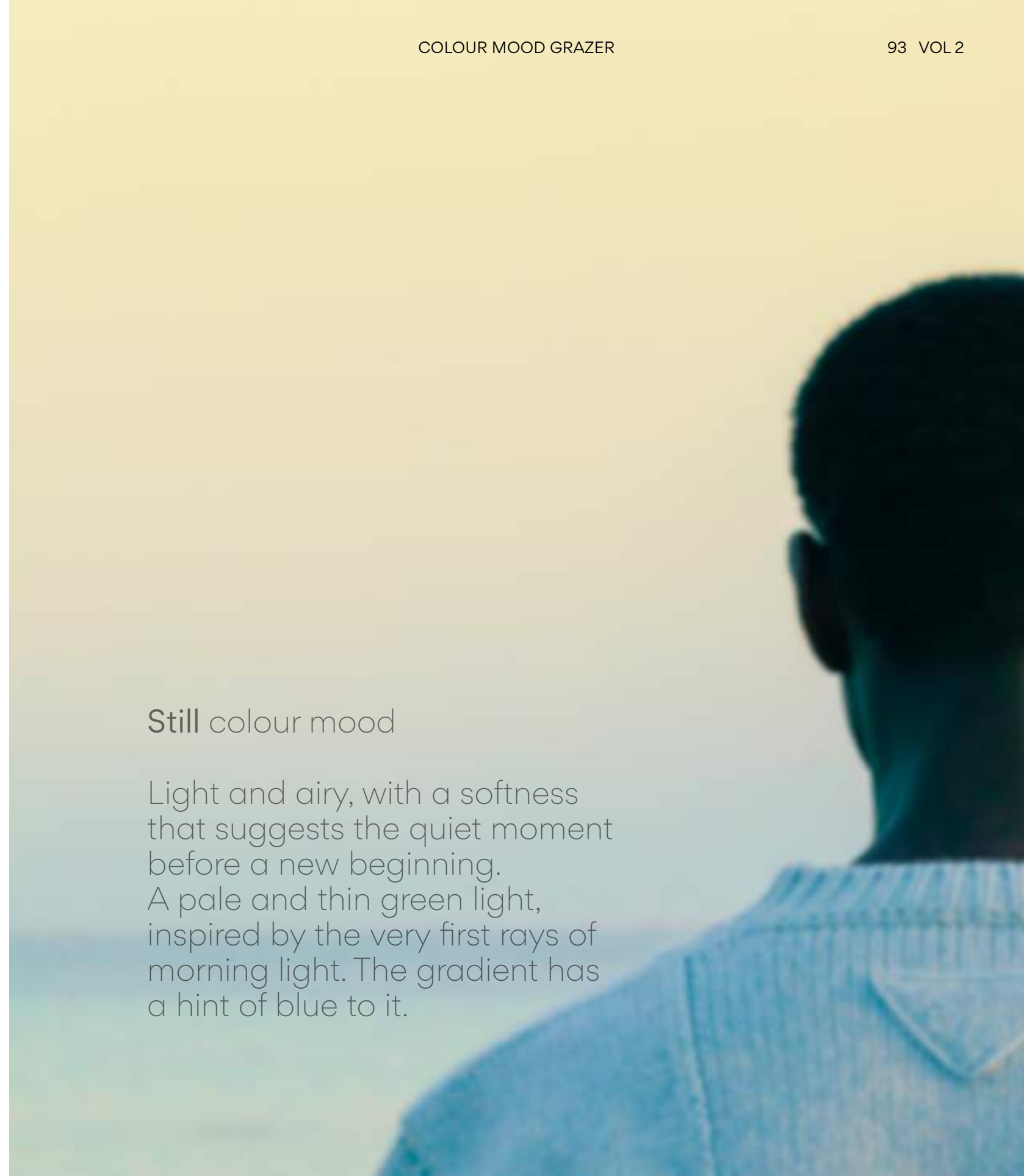

# Offset

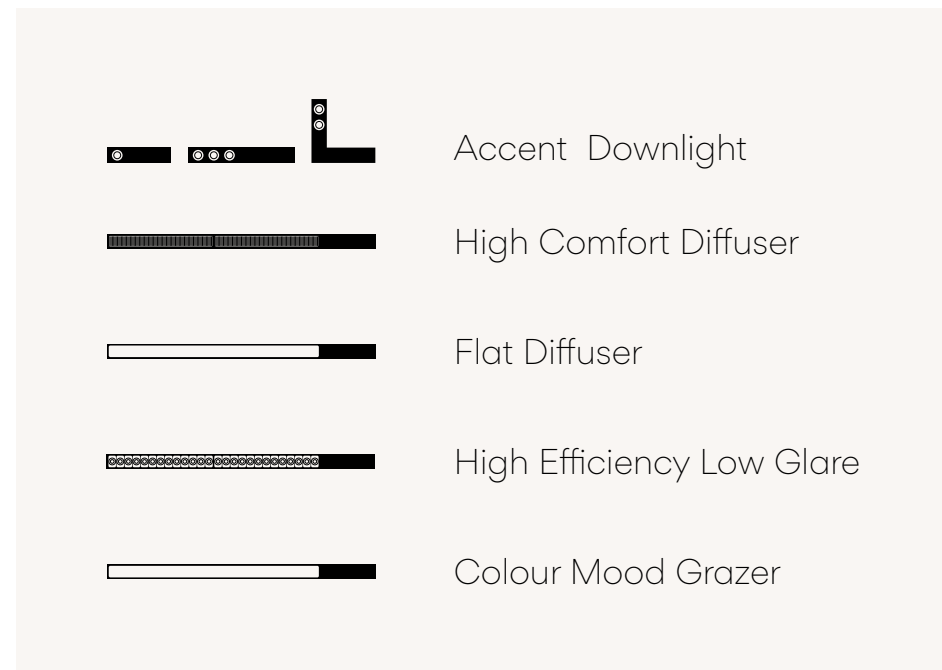

Design by Xuclà.

Offset combines intuitive lighting with an industrial, geometric silhouette. A complementary system of superficial ceiling fixtures, the collection integrates five lighting effects with advanced colour and temperature regulation for a carefully curated atmosphere.

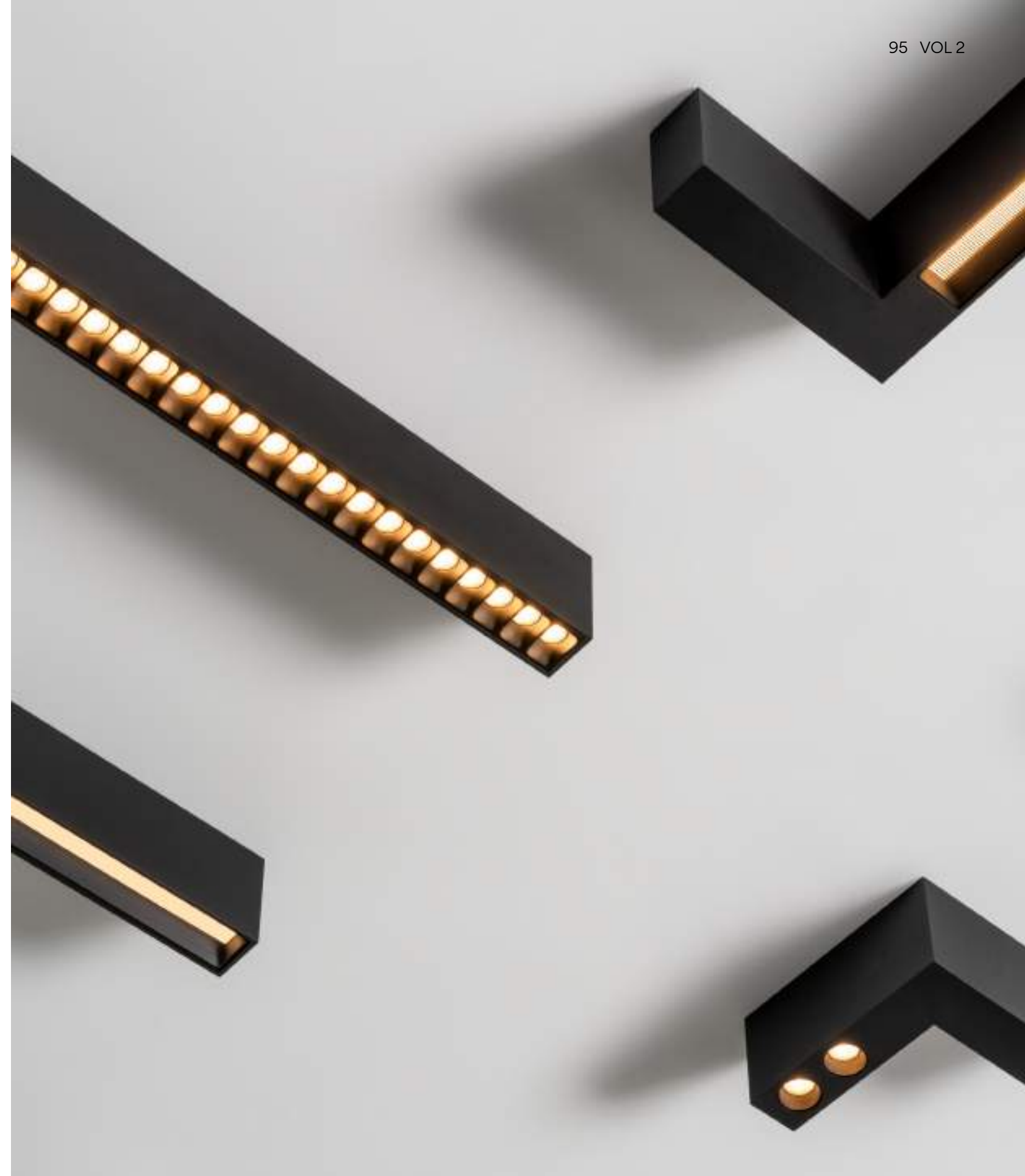

## Dynamic light

Dynamic light allows professionals to play with subtle degrees of intensity and colour temperature to recreate a subtle ambience for every scene within a lighting project

Designing an atmosphere of wellbeing is based on two main axes: **space** and **time**. The axis of time implies the concept of dynamic light.

Atmosphere design is intentional, depending on the **design of different scenes according to the specific use of a space** as it evolves throughout the day. Light is dynamic because ambience also depends **on the time of day** and on the influence of the natural light at every moment.



Throughout the day our circadian rhythms respond primarily to light, which regulates our sense of physical and mental wellbeing

## Comfortable environments

Vibia's spot accent, downlight and general lighting luminaires include the option of tunable white. Combining these zenithal tunable white lights with the rest of the diffused and indirect lighting effects of Vibia's portfolio, you can design the perfect scene for every moment and use.

Tunable lighting allows for comprehensive temperature regulation and intensity: colour temperature can be precisely tuned depending on the desired atmosphere for every scene.

### Static White



### Tunable White

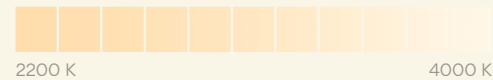

Contact Vibia Support Service at [vibia.com](http://vibia.com) for any kind of assistance or recommendation when designing an atmosphere of wellbeing, or if you require support with control system approach.



## Accent Downlight

A complementary system of graphic fixtures, Offset accommodates ceilings that don't allow for recessed fittings. Ideal for transitional spaces, the accent downlight is visually compact. Pinpoints of light set into its robust aluminium casing attract a relaxed gaze towards the illuminated surface. Designers can experiment with composition, incorporating various lengths and angles to create a distinctly modular design.

- 11 Black (NCS S 8500-N)
- 23 Warm White (NCS S 0502-Y50R)
- 24 Beige M1 (NCS S 2005-Y50R)

Body: Aluminum

**LED Colour Temperature**  
2700 K; 3000 K; 3500 K  
285 lm 2,9W  
CRI>90

### Control

Analog: Push  
Digital: DALI-2  
Smart: Casambi; ProtoPixel\*

\*ProtoPixel products are compatible with all other DALI-2 products via a designated gateway (please consult us)

### Electrical connection

Surface (Driver included)

Updated detailed spec sheets on [vibia.com](http://vibia.com)

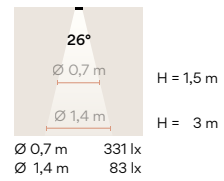

**1720**  
15 x 4 x 7 cm

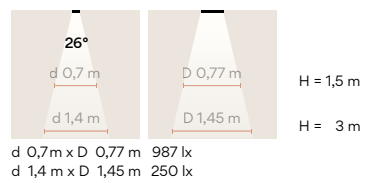

**1722**  
25 x 4 x 7 cm

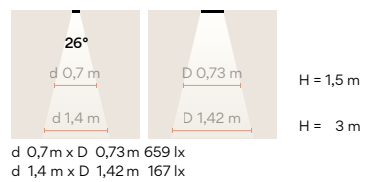

**1725**  
15 x 15 x 7 cm



**1727**  
15 x 15 x 7 cm

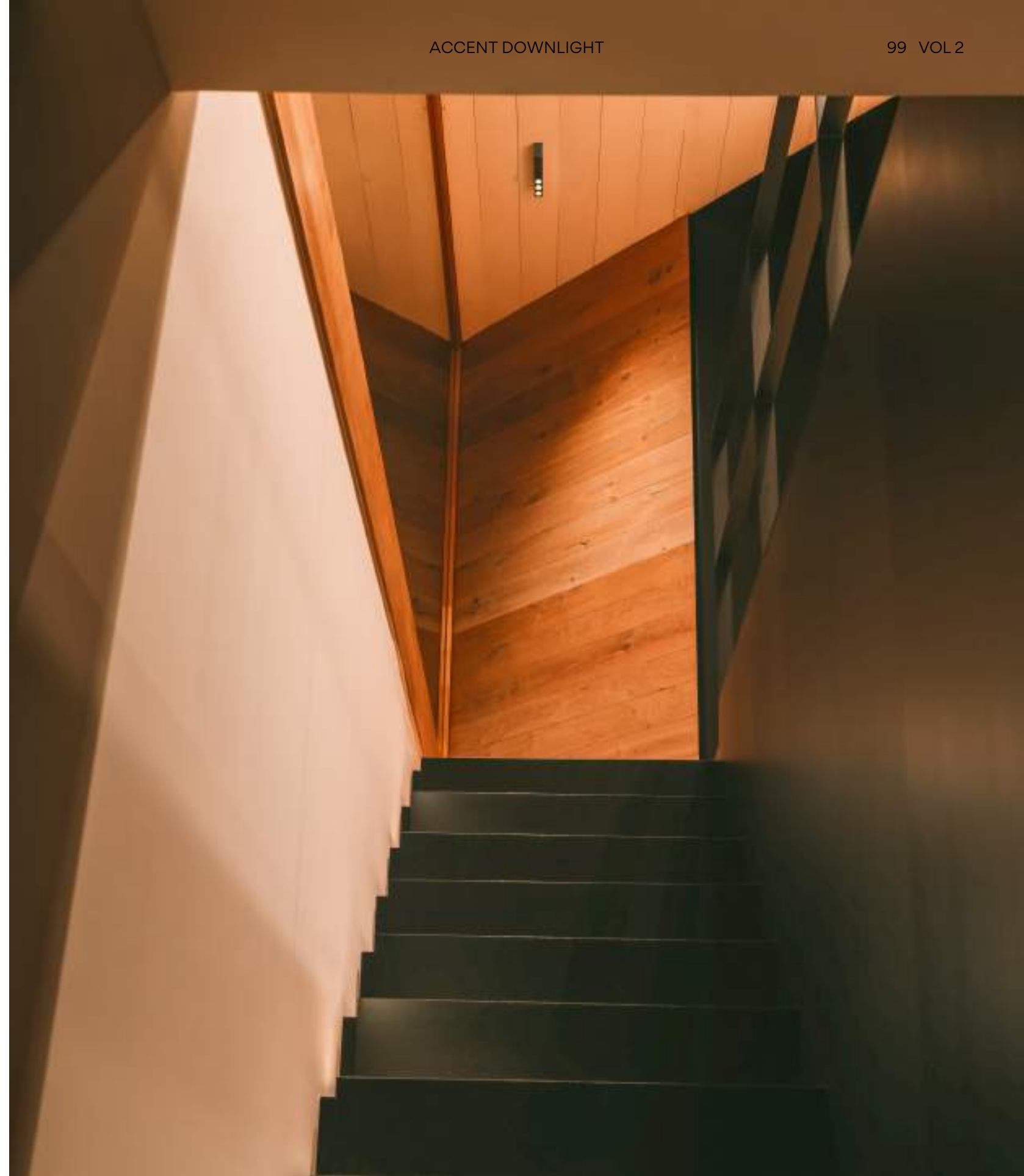





## High Comfort Diffuser

Particularly suited to residential hallways or corridors, the High Comfort Diffuser comes in a broad range of lengths. The aluminium frame is fitted with high performance LED strips that provide diffuse, homogeneous illumination for a smooth and relaxed ambience.

- 11 Black (NCS S 8500-N)
- 23 Warm White (NCS S 0502-Y50R)
- 24 Beige M1 (NCS S 2005-Y50R)

Body: Aluminum  
Diffuser: PC- Polycarbonate



**1728**  
40 x 4 x 7 cm



**1730**  
65 x 4 x 7 cm



**1735**  
100 x 4 x 7 cm



**1740**  
31 x 15 x 7 cm



**1745**  
31 x 15 x 7 cm

### LED Colour Temperature

Static White  
2700 K; 3000 K; 3500 K  
Tunable White (2200 K - 4000 K)  
CRI>90

### Control

Analog: Push.  
Digital: DALI-2; DALI-2 DT8  
Smart: Casambi; ProtoPixel\*  
\*ProtoPixel products are compatible with all other DALI-2 products via a designated gateway (please consult us)

### Electrical connection

Surface (Driver included)

Updated detailed spec sheets on [vibia.com](http://vibia.com)



## Flat Diffuser

The Flat Diffuser guarantees a calm and comfortable atmosphere.

- 11 Black (NCS S 8500-N)
- 23 Warm White (NCS S 0502-Y50R)
- 24 Beige M1 (NCS S 2005-Y50R)

Body: Aluminum  
Diffuser: PC- Polycarbonate

### LED Colour Temperature

Static White  
2700 K; 3000 K; 3500 K  
Tunable White (2200 K - 4000 K)  
CRI>90

### Control

Digital: DALI-2; DALI-2 DT8  
Smart: Casambi; ProtoPixel\*

\*ProtoPixel products are compatible with all other DALI-2 products via a designated gateway (please consult us)

### Electrical connection

Surface (Driver included)

Updated detailed spec sheets on [vibia.com](http://vibia.com)



**1755**  
125 x 4 x 7 cm



**1757**  
225 x 4 x 7 cm





Casting a pleasant, uniform, 360° light, the Flat Diffuser ensures a calm and luminous environment

## High Efficiency Low Glare

Eliminating unwanted glare, the Low-Glare High-Efficiency model provides comfortable general lighting suitable for transitional spaces and working environments such as libraries or offices.

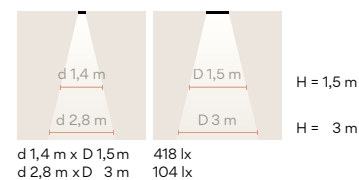
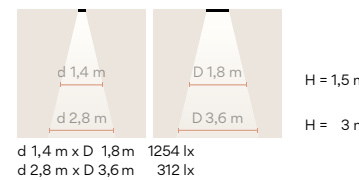
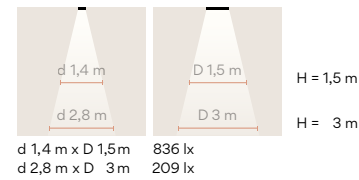
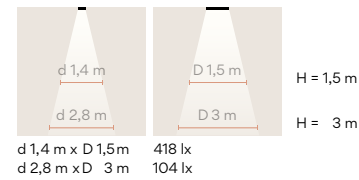

- 11 Black (NCS S 8500-N)
- 23 Warm White (NCS S 0502-Y50R)
- 24 Beige M1 (NCS S 2005-Y50R)

Body: Aluminum  
Diffuser: PC- Polycarbonate

### LED Colour Temperature

Ref. 1729 and 1732  
Static White  
2700 K - 3348 lm  
3000 K - 3466 lm  
3500 K - 3582 lm  
20,8W 27,4W  
Tunable White (2200 K - 4000 K)  
1842 lm - 2150 lm 20,8W

Ref. 1737  
Static White  
2700 K - 5022 lm  
3000 K - 5199 lm  
3500 K - 5373 lm  
41,1W  
Tunable White (2200 K - 4000 K)  
2763 lm - 3225 lm 31,2W

Ref. 1742 and 1747  
Static White  
2700 K - 1674 lm  
3000 K - 1733 lm  
3500 K - 1791 lm  
13,7W  
Tunable White (2200 K - 4000 K)  
921 lm - 1075 lm 10,4W  
CRI>90

### Control

Analog: Push.  
Digital: DALI-2; DALI-2 DT8  
Smart: Casambi; ProtoPixel\*  
\*ProtoPixel products are compatible with all other DALI-2 products via a designated gateway (please consult us)

### Electrical connection

Surface (Driver included)

Updated detailed spec sheets on [vibia.com](http://vibia.com)

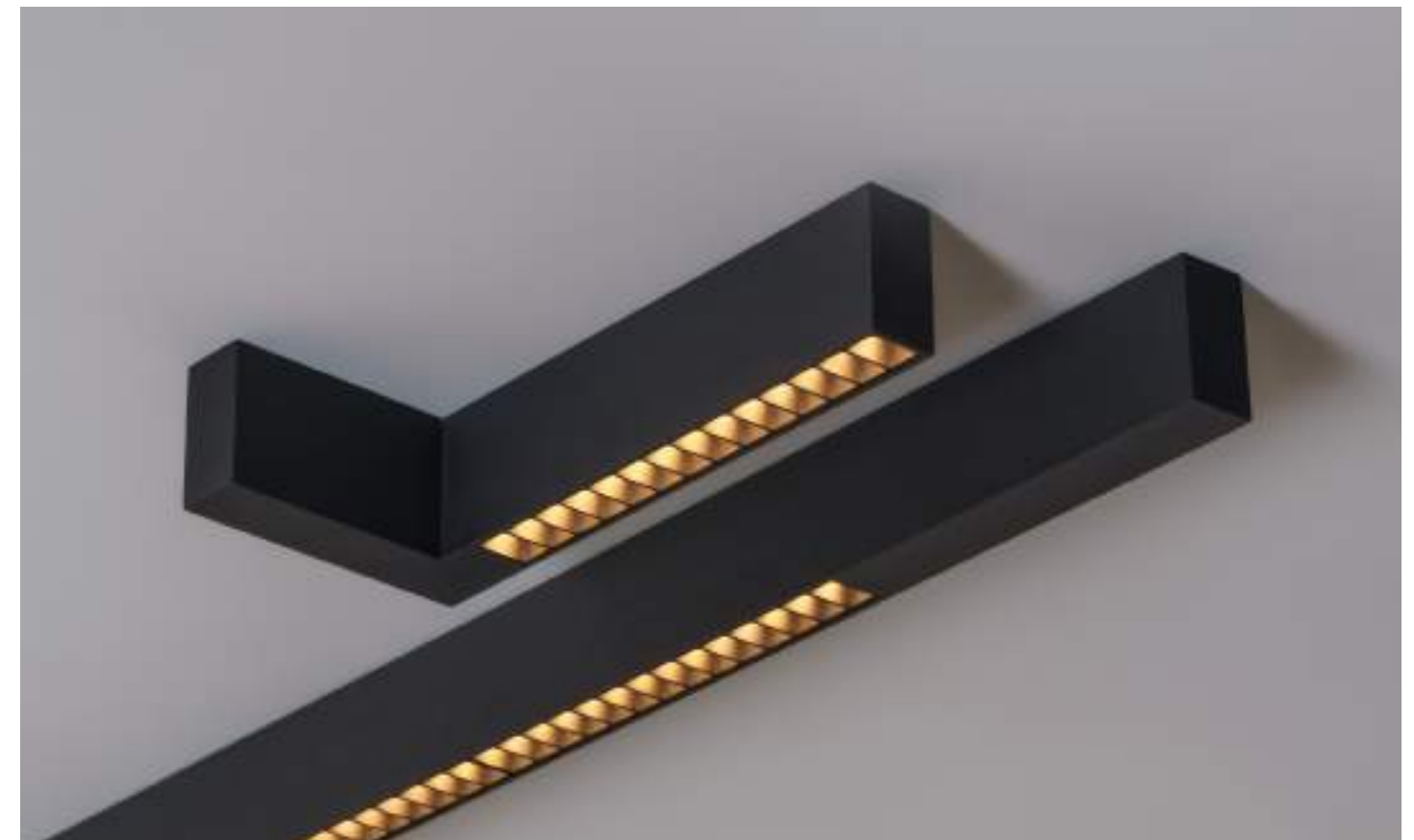



## Colour Mood Grazer

Natural light is never mono-tonal. The Colour Mood Grazer is an elegant solution where either Tunable White or Infinite Colour regulation is desired. Infinite Colour incorporates six static colours and six gradients, each spectrum unique to Vibia and designed to transmit a particular kind of sensation or mood. The installer plays a fundamental role in programming the appropriate lighting mode for the space and its desired use.



- 11 Black (NCS S 8500-N)
- 23 Warm White (NCS S 0502-Y50R)
- 24 Beige M1 (NCS S 2005-Y50R)

Diffuser: PC- Polycarbonate  
 Lens: PMMA



**LED Colour Temperature**  
 Infinite Colour (TW + RGB)  
 CRI >90

**Control**  
 Smart: ProtoPixel\*  
 \*ProtoPixel products are compatible with all other DALI-2 products via a designated gateway (please consult us)

**Electrical connection**  
 Surface (Driver included)

Updated detailed spec sheets on [vibia.com](http://vibia.com)



Right Left  
**1760 1762**  
 7 x 125 x 5 cm



Right Left  
**1765 1767**  
 7 x 225 x 5 cm



**Dynamic light**  
 Like the natural light that ascends gradually at dawn or dusk, following circadian rhythms, our infinite colour gradients add layers of visual depth and emotion, adapting to specific scenes and moods by creating a nuanced atmosphere.



## A source of emotion

Colour is a source of emotion it can instantly set a mood, convey a feeling or generate a sense of wellbeing

Vibia's approach to coloured light invites the use of colour and gradients to create and experience different atmospheres, making them as natural and subtle as possible. Natural light is never mono-tonal. Gradients come in infinite colours.



## Vibia Chromatica colours of light

### Static White

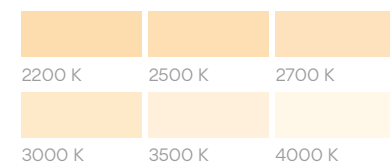

You can select any desired light -white, colour mood or gradient- and intensity manually from the analogic product interface. You can also integrate your selection into the control system for specific scene design and activate it using the Vibia App

### Colour Moods

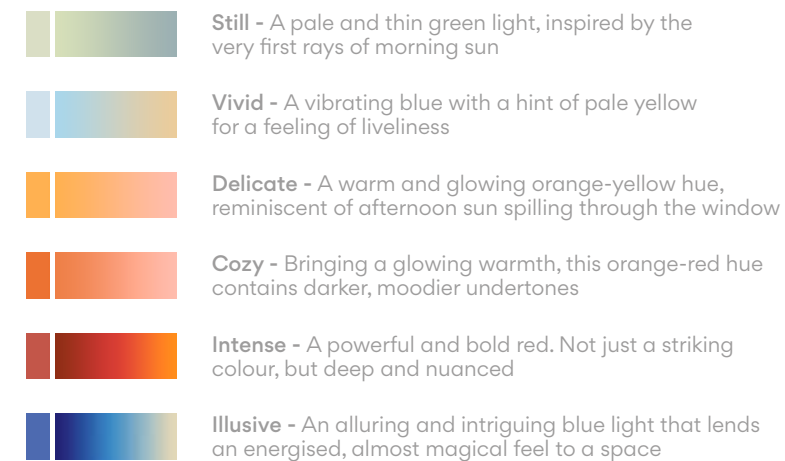

Contact Vibia Support Service at [vibia.com](http://vibia.com) for any kind of assistance or recommendation when designing an atmosphere of wellbeing, or if you require support with control system approach.





# Palma

Design by Antoni Arola.

Antoni Arola brings an entirely new dimension to the Palma collection with a new ceiling edition. A central aluminium shaft extends vertically into the room, decorated with a choice of either two or four distinctive Palma spheres. Positioned at different heights and angles, they form an organic structure, projecting a warm, diffuse light in all directions.



3760  
50 x 61 cm



3764  
50 x 74 cm



● 18 Graphite (ADAPTA RF 9913 WX)

Diffuser: Blown-glass  
Profile: Aluminum

**LED Colour Temperature**

2700 K  
CRI>90

**Control**

Analog: Push; 1-10V  
Digital: DALI-2  
Smart: Casambi

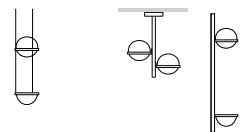

Pg 170 VOL 1 Pg 116/256 VOL 2





# Plusminus Solo

Design by Diez Office.

The ceiling range can be mounted as desired, creating visual hierarchy by directing the gaze towards specific features within a space, and combined to form intriguing compositions.

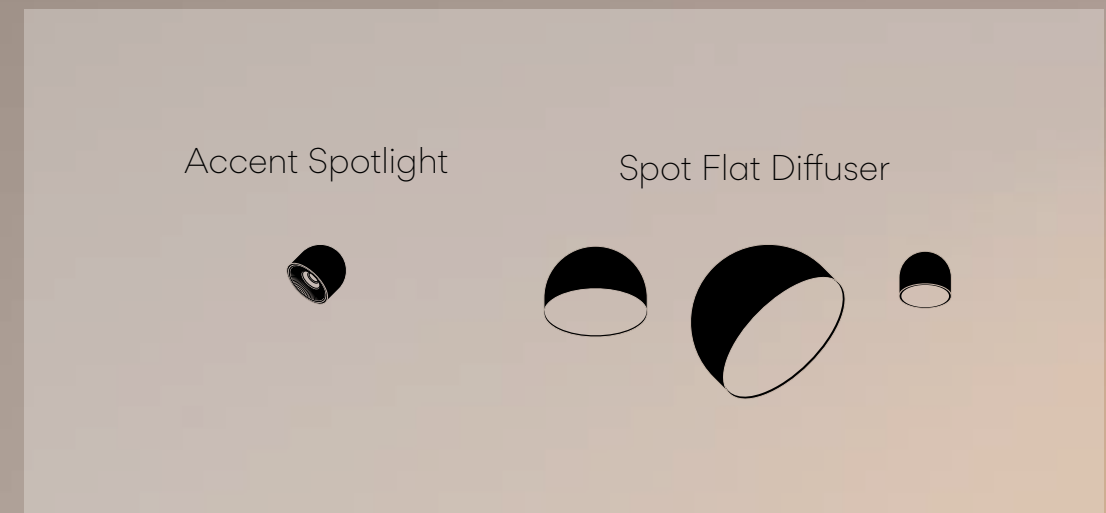



Plusminus Solo expands to include a range of surface mounted semi-spherical ceiling lights. Combining Accent Spotlights with Directed Flat Diffusers, the collection provides comfortable general lighting as well as more pointed illumination. Available in five elegant finishes, the set is designed to adapt to a range of contemporary interior styles.



- 11 Black (NCS S 8500-N)
- 24 Beige M1 (NCS S 2005-Y50R)
- 37 Terra Red (NCS S 4040-Y70R)
- 42 Blue M1 (NCS S 5010-B10G)
- 53 Green M1 (NCS S 6005-G80Y)

Body: Aluminum  
Diffuser: PC- Polycarbonate

**LED Colour Temperature**

**Accent**

2700 K - 941 lm  
3000 K - 987 lm  
3500 K - 1022 lm  
7,9W

CRI>90

**Flat diffuser**

LED 2700 K; 3000 K; 3500 K

CRI>90

**Control**

Analog: On/ Off; Push; 1-10V

Digital: DALI-2

Smart: Casambi

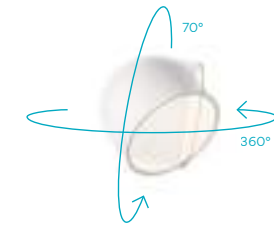

Updated detailed spec sheets on [vibia.com](http://vibia.com)

To see **Plusminus** collection go to page **p. 272 VOL 1**



Remote version Built-in

SPOTLIGHT



Accent

**6330** Narrow  
**6331** Medium  
**6332** Wide  
Ø 10 cm



Flat diffuser

**6333**  
Ø 10 cm

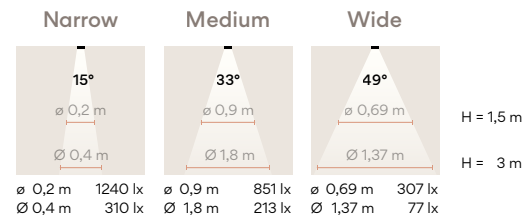

SEMISPHERE



Flat diffuser

**6335**  
Ø 20 cm



Flat diffuser

**6340**  
Ø 30 cm



# Bind

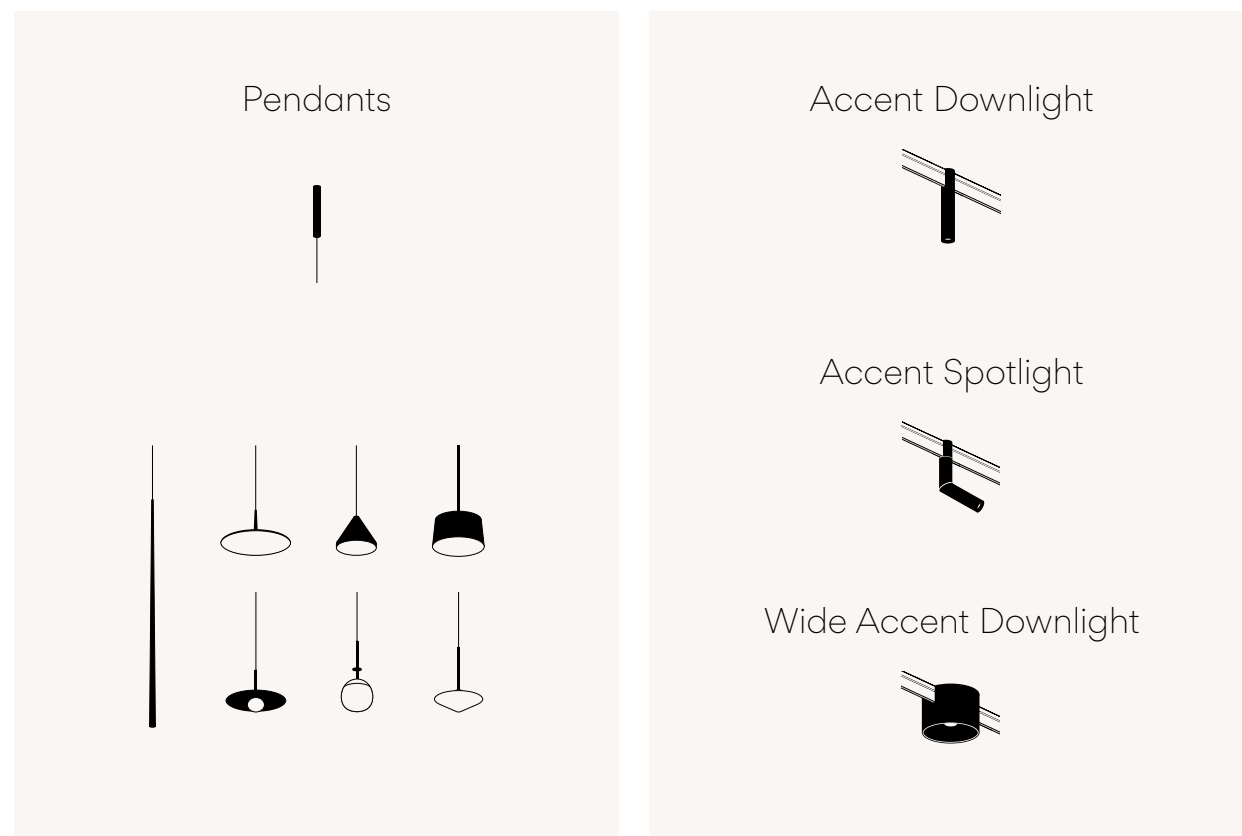

Design by Martín Azúa.

Bind is a hybrid lighting system designed to create multiple atmospheres to suit a range of spaces, uses and moods. It allows professionals to experiment with different lighting typologies and levels of density, modelling a space by generating subtle gradients between soft and more accentuated light.



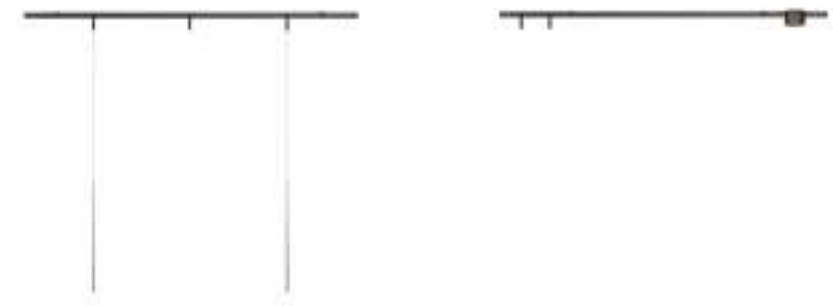



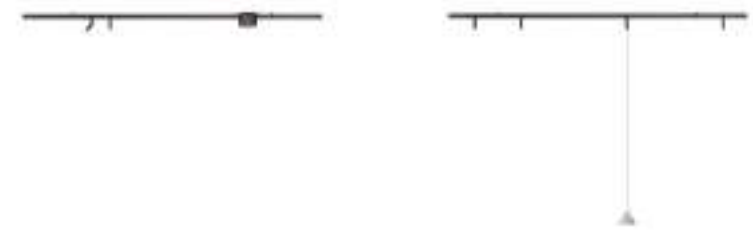

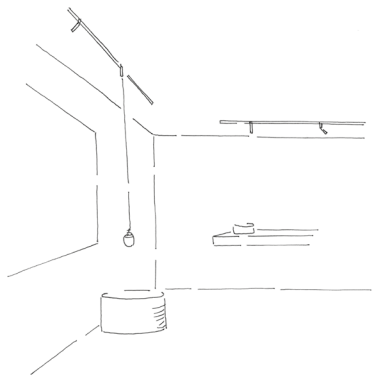



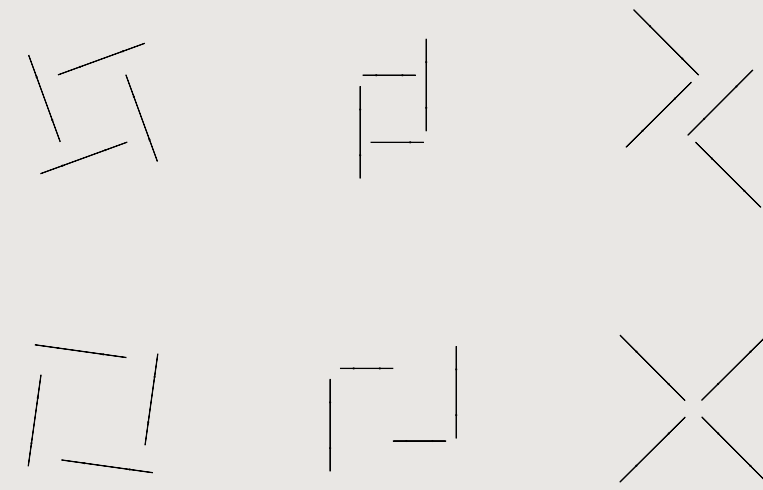
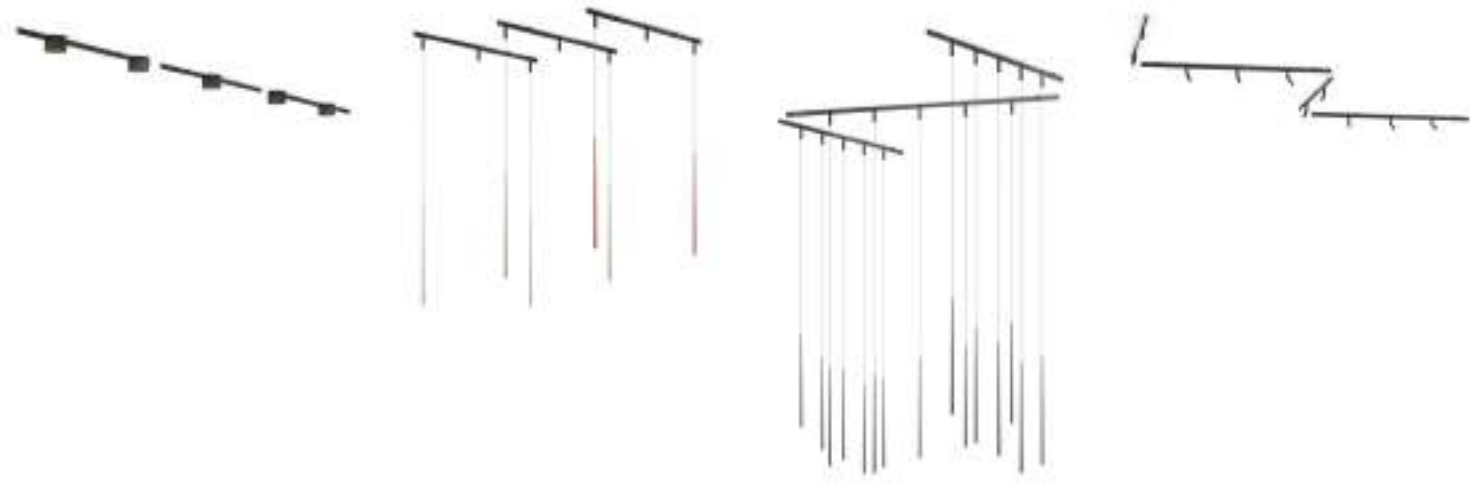

## Ceiling Tracks

The Bind collection features ceiling surface track lighting as well as a range of independent elements that can be fitted directly to the ceiling. The connective quality, ease of installation and versatility of this fully modular system facilitates holistic solutions to complex demands.

- 11 Black (NCS S 8500-N)
- 24 Beige M1 (NCS S 2005-Y50R)

Track: Aluminum  
Canopy: Aluminum

### Electrical connection options



Surface    Remote

- A491 120 cm
- A492 210 cm
- A493 300 cm



## Dynamic light

Dynamic light allows professionals to play with subtle degrees of intensity and colour temperature to recreate a subtle ambience for every scene within a lighting project

Designing an atmosphere of wellbeing is based on two main axes: **space** and **time**. The axis of time implies the concept of dynamic light .

Atmosphere design is intentional, depending on the **design of different scenes according to the specific use of a space** as it evolves throughout the day. Light is dynamic because ambience also depends on **the time of day** and on the influence of the natural light at every moment.



Throughout the day our circadian rhythms respond primarily to light, which regulates our sense of physical and mental wellbeing

## Comfortable environments

Vibia's spot accent, downlight and general lighting luminaires include the option of tunable white. Combining these zenithal tunable white lights with the rest of the diffused and indirect lighting effects of Vibia's portfolio, you can design the perfect scene for every moment and use.

Tunable lighting allows for comprehensive temperature regulation and intensity: colour temperature can be precisely tuned depending on the desired atmosphere for every scene.

### Static White

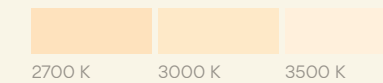

### Tunable White

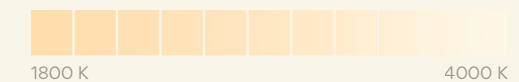

Contact Vibia Support Service at [vibia.com](http://vibia.com) for any kind of assistance or recommendation when designing an atmosphere of wellbeing, or if you require support with control system approach..



As a ceiling track, Bind easily integrates within the existing architecture. Multiple fixtures can be connected at any point using a pincer, oriented to direct light in various directions.

- 11 Black (NCS S 8500-N)
- 24 Beige M1 (NCS S 2005-Y50R)

Lens: PMMA  
Body: Aluminum

**LED Colour Temperature**

Ø 3 cm  
Static White  
2700 K - 451 lm  
3000 K - 471 lm  
3500 K - 489 lm  
4,3W

Ø 4 cm  
Static White  
2700 K - 530 lm  
3000 K - 554 lm  
3500 K - 574 lm  
5,2W

Only Ref. 6525, 6529, 6534 and 6538  
Tunable White (1800 K - 4000 K)  
308 lm - 504 lm 5,5W  
CRI>90

**Control**

Analog: On/ Off; 1-10V; Push (simultaneous line)  
Digital: DALI-2 (simultaneous line); Smart: Casambi (simultaneous line); Casambi (P2P); ProtoPixel\* (P2P)

\*ProtoPixel products are compatible with all other DALI-2 products via a designated gateway (please consult us)

Updated detailed spec sheets on [vibia.com](http://vibia.com)



Accent Downlight

Accent Spotlight

DOWNLIGHT Ø 3 cm

SPOTLIGHT Ø 3 cm

6500 Narrow  
6504 Medium

Ø 3 x 15 cm



6510 Narrow  
6514 Medium

Ø 3 x 20 cm



Narrow

Medium

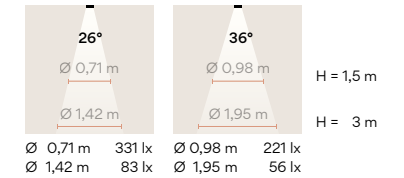

DOWNLIGHT Ø 4 cm

SPOTLIGHT Ø 4 cm

6520 Narrow  
6524 Medium  
6528 Wide

Ø 4 x 17,5 cm



6530 Narrow  
6534 Medium  
6538 Wide

Ø 4 x 22,5 cm



Narrow

Medium

Wide

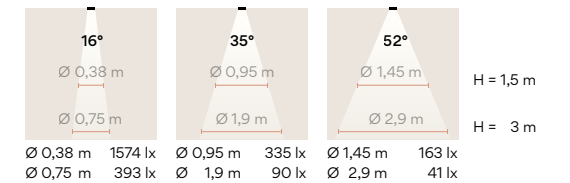

6525 Medium  
6529 Wide

Ø 4 x 20 cm

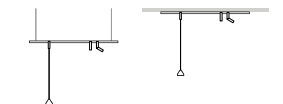



To highlight a particular activity zone or feature, Bind is compatible with a wide accent downlight fixture that provides functional diffuse and accented lighting.

- 11 Black (NCS S 8500-N)
- 24 Beige M1 (NCS S 2005-Y50R)

Lens: PC- Polycarbonate  
Body: Aluminum

#### LED Colour Temperature

Static White  
2700 K - 1256 lm  
3000 K - 1313 lm  
3500 K - 1360 lm  
12,4W  
Tunable White (1800 K - 4000 K)  
Smart (P2P)  
571 lm - 895 lm 8,9W  
CRI>90

#### Control

Analog: On/ Off; 1-10V; Push (simultaneous line)  
Digital: DALI-2 (simultaneous line)  
Smart: Casambi (simultaneous line); Casambi (P2P); ProtoPixel\* (P2P)

\*ProtoPixel products are compatible with all other DALI-2 products via a designated gateway (please consult us)

Updated detailed spec sheets on [vibia.com](http://vibia.com)

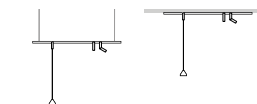

Pg 240 VOL 1 Pg 128 VOL 2

## Wide Accent Downlight

6540 Medium  
6542 Wide

Ø 18,5 cm

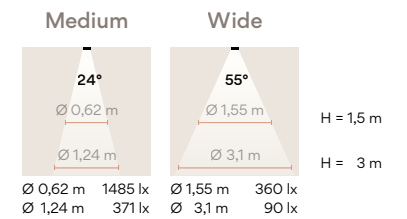

Bind track is compatible with the Skan, Slim, North, Tempo and Tube pendant collections, presenting a range of decorative silhouettes with multiple lighting effects. Single or multiple pendants can be suspended as desired, allowing for the formation of intricate chandeliers created from a compilation of tracks with multiple pendants.

Track adapter: Aluminum

**LED Colour Temperature**

2700 K; 3000 K; 3500 K  
CRI>90

**Control**

Analog: On/Off; Push; 1-10V (simultaneous line);  
Digital: DALI-2 (simultaneous line);  
Smart: Casambi (simultaneous line); Casambi (P2P); ProtoPixel (P2P)

Updated detailed spec sheets on [vibia.com](http://vibia.com)



Track adapter

- Black (NCS S 8500-N)
- Beige M1 (NCS S 2005-Y50R)



6560 (Black)  
6561 (Beige)

**Skan Colours**

- 10 White (NCS S 0300-N)
- 11 Black (NCS S 8500-N)
- 24 Beige M1 (NCS S 2500-Y50R)
- 37 Terra Red (NCS S 4040-Y70R)
- 42 Blue M1 (NCS S 5010-B10G)
- 47 Green L1 (NCS S 4005-G80Y)



6570 (Black)  
6571 (Beige)

**Slim Colours**

- 10 White (NCS S 0300-N)
- 11 Black (NCS S 8500-N)
- 24 Beige M1 (NCS S 2500-Y50R)
- 37 Terra Red (NCS S 4040-Y70R)
- 47 Green L1 (NCS S 4005-G80Y)
- 68 Ocre (NCS S 3050-Y30R)



6575 (Black)  
6576 (Beige)

**North Colours**

- 10 White (NCS S 0300-N)
- 11 Black (NCS S 8500-N)
- 24 Beige M1 (NCS S 2500-Y50R)
- 42 Blue M1 (NCS S 5010-B10G)



6590 (Black)  
6591 (Beige)

**Tube Colours**

- 10 White (NCS S 0300-N)
- 15 Grey L2 (NCS S 2500-N)
- 16 Grey M1 (NCS S 4500-N)
- 21 Black Grey (NCS S 7000-N)
- 24 Beige (NCS S 2500-Y50R)
- 37 Terra Red (NCS S 4040-Y70R)



6580 (Black)  
6581 (Beige)

**Tempo Colours**

- 18 Graphite (ADAPTA RF9913WX)
- 37 Terra Red (NCS S 4040-Y70R)
- 58 Cream (RAL 7044)
- 62 Green (NCS S 3010-G20Y)



6583 (Black)  
6584 (Beige)

**Tempo Colours**

- 18 Graphite (ADAPTA RF9913WX)
- 37 Terra Red (NCS S 4040-Y70R)
- 58 Cream (RAL 7044)
- 62 Green (NCS S 3010-G20Y)



6586 (Black)  
6587 (Beige)

**Tempo Colours**

- 18 Graphite (ADAPTA RF9913WX)
- 37 Terra Red (NCS S 4040-Y70R)
- 58 Cream (RAL 7044)
- 62 Green (NCS S 3010-G20Y)

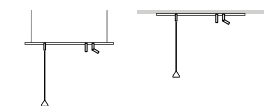



# Bind Solo

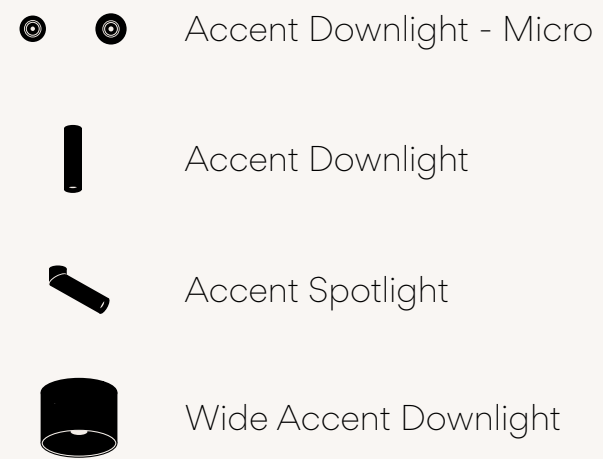

Bind Solo provides a set of tools to play with contrasts, defining functional and transitional areas, as well as hybrid activity zones. The range can be mounted to the ceiling as desired, creating visual hierarchy by directing the gaze towards specific features and combining to form unique compositions overhead.



## Dynamic light

Dynamic light allows professionals to play with subtle degrees of intensity and colour temperature to recreate a subtle ambience for every scene within a lighting project

Designing an atmosphere of wellbeing is based on two main axes: **space** and **time**. The axis of time implies the concept of dynamic light.

Atmosphere design is intentional, depending on the **design of different scenes according to the specific use of a space** as it evolves throughout the day. Light is dynamic because ambience also depends **on the time of day** and on the influence of the natural light at every moment.



Throughout the day our circadian rhythms respond primarily to light, which regulates our sense of physical and mental wellbeing

## Comfortable environments

Vibia's spot accent, downlight and general lighting luminaires include the option of tunable white. Combining these zenithal tunable white lights with the rest of the diffused and indirect lighting effects of Vibia's portfolio, you can design the perfect scene for every moment and use.

Tunable lighting allows for comprehensive temperature regulation and intensity: colour temperature can be precisely tuned depending on the desired atmosphere for every scene.

### Static White



### Tunable White

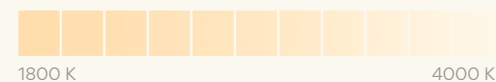

Contact Vibia Support Service at [vibia.com](http://vibia.com) for any kind of assistance or recommendation when designing an atmosphere of wellbeing, or if you require support with control system approach.

The simplest and most effective solution for your projects



## Accent Downlight - Micro

Bind Solo offers a range of scope apertures to choose from depending on the desired scenography. Thanks to a micro-profile variation, the Accent Downlight offers seamless integration within the surrounding architecture.

- 11 Black (NCS S 8500-N)
- 24 Beige M1 (NCS S 2005-Y50R)

Lens: PMMA  
Body: Aluminum

## LED Colour Temperature

Ø3 cm

Static White  
2700K - 451 lm  
3000K - 471 lm  
3500K - 489 lm  
4,3W

Ø4 cm

Static White  
2700 K - 530 lm  
3000 K - 554 lm  
3500 K - 574 lm  
5,2W

Only ref. 6654, 6658  
Tunable White (1800 K - 4000 K)  
308 lm - 504 lm 5,5W

CRI>90

## Control

Analog: On/ Off; Push  
Digital: DALI-2\*; DALI-2 DT8\*  
Smart: Casambi

\*DALI-2 products are compatible (via a designated gateway) with all ProtoPixel dynamic-light solution products.

Visit [vibia.com](http://vibia.com) to group several pieces with just one electrical point

Updated detailed spec sheets on [vibia.com](http://vibia.com)



6600 Narrow  
6604 Medium

Ø 3 cm

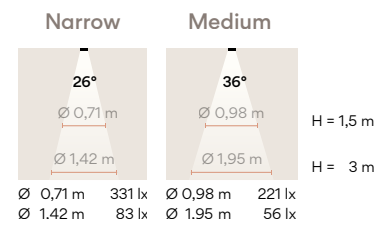

6650 Narrow  
6654 Medium  
6658 Wide

Ø 4 cm

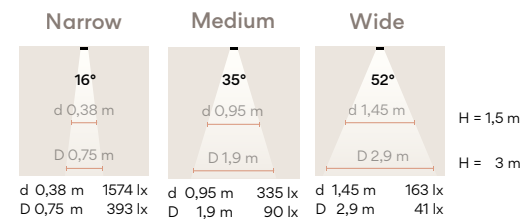



## Accent Downlight

For a visually compelling variation, Bind Solo also offers a superficial Accent Downlight in various diameters and lengths. The range of apertures allows for precise modelling of the space using light and shadow.

- 11 Black (NCS S 8500-N)
- 24 Beige M1 (NCS S 2005-Y50R)

Lens: PMMA  
 Body: Aluminum  
 Ceiling support: Aluminum

### LED Colour Temperature

Ø3 cm  
 Static White  
 2700 K - 451 lm  
 3000 K - 471 lm  
 3500 K - 489 lm  
 4,3W

Ø4 cm  
 Static White  
 2700 K - 530 lm  
 3000 K - 554 lm  
 3500 K - 574 lm  
 5,2W

Only ref. 6664, 6668, 6684, 6688  
 Tunable White (1800 K - 4000 K)  
 308 lm - 504 lm  
 5,5W

CRI>90

### Control

Analog: On/Off; Push  
 Digital: DALI-2\*; DALI-2 DT8\*  
 Smart: Casambi

\*DALI-2 products are compatible (via a designated gateway) with all ProtoPixel dynamic-light solution products.

### Electrical connection

Remote (Driver included)

Visit [vibia.com](http://vibia.com) to group several pieces with just one electrical point

Updated detailed spec sheets on [vibia.com](http://vibia.com)



DOWNLIGHT Ø 3 cm

**6610** Narrow      **6630** Narrow  
**6614** Medium      **6634** Medium

Ø 3 x 4 cm      Ø 3 x 10 cm

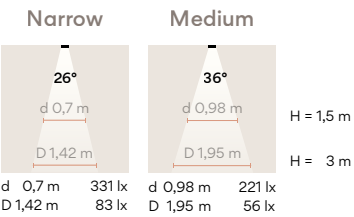

DOWNLIGHT Ø 4 cm

**6660** Narrow      **6680** Narrow  
**6664** Medium      **6684** Medium  
**6668** Wide      **6688** Wide

Ø 4 x 7 cm      Ø 4 x 10 cm

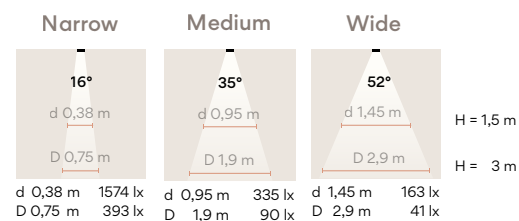

Combining Accent Spotlights with Standard and Wide Accent Downlights, the Bind Solo collection provides comfortable general lighting as well as pointed illumination. Designed to complement Vibia's wider product range, it allows professionals to experiment with light density, combining different lighting typologies to create dynamic and restorative atmospheres.

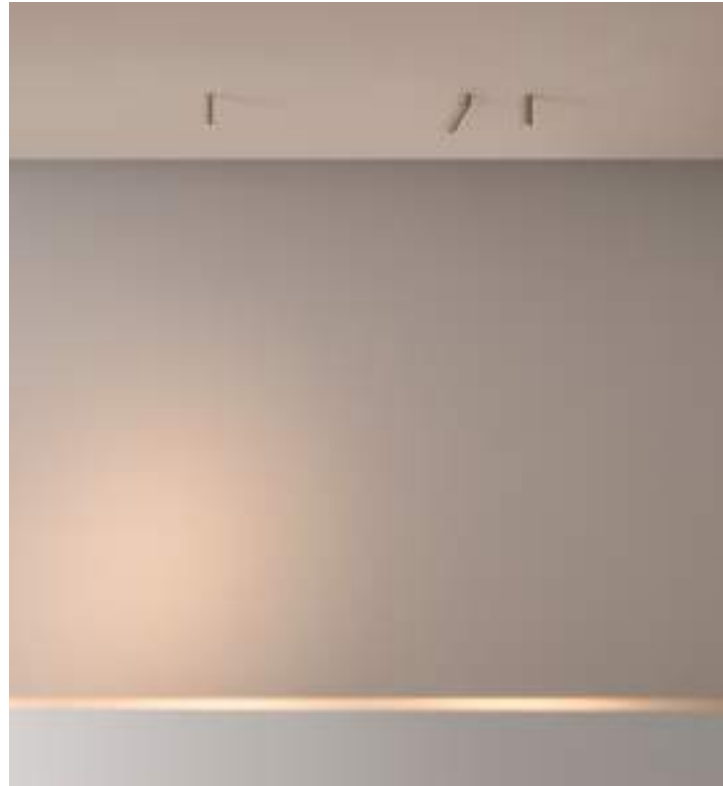

## Accent Spotlight

To highlight a particular activity zone or feature, Bind Solo incorporates a series of fixed-angle spots of various lengths.

- 11 Black (NCS S 8500-N)
- 24 Beige M1 (NCS S 2005-Y50R)

Lens: PMMA  
 Body: Aluminum  
 Ceiling support: Aluminum

### LED Colour Temperature

Ø3 cm

Static White  
 2700 K - 451 lm  
 3000 K - 471 lm  
 3500 K - 489 lm  
 4,3W

Ø4 cm

Static White  
 2700 K - 530 lm  
 3000 K - 554 lm  
 3500 K - 574 lm  
 5,2W

Only ref. 6674, 6678, 6694, 6698  
 Tunable White (1800 K - 4000 K)  
 308 lm - 504 lm  
 5,5W

CRI>90

### Control

Analog: On/Off; Push  
 Digital: DALI-2\*; DALI-2 DT8\*  
 Smart: Casambi

\*DALI-2 products are compatible (via a designated gateway) with all ProtoPixel dynamic-light solution products.

### Electrical connection

Remote (Driver included)

Visit [vibia.com](http://vibia.com) to group several pieces with just one electrical point

Updated detailed spec sheets on [vibia.com](http://vibia.com)



### SPOTLIGHT Ø 3 cm

- 6620 Narrow
- 6624 Medium
- 6640 Narrow
- 6644 Medium

Ø 3 x 7 cm

Ø 3 x 11,5 cm



Narrow

Medium

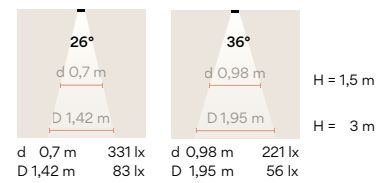

### SPOTLIGHT Ø 4 cm

- 6670 Narrow
- 6674 Medium
- 6678 Wide
- 6690 Narrow
- 6694 Medium
- 6698 Wide

Ø 4 x 10 cm

Ø 4 x 14 cm



Narrow Medium Wide

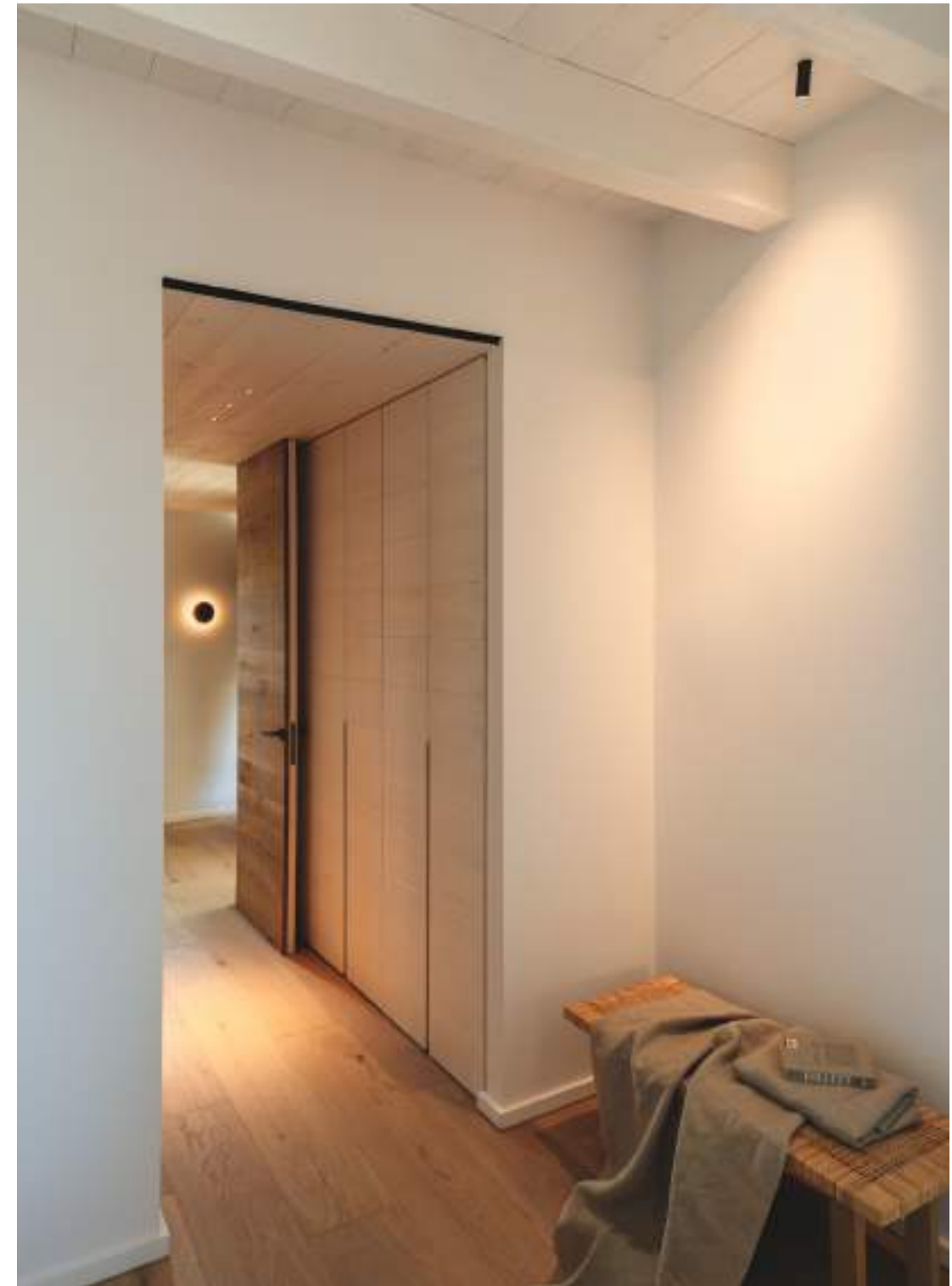
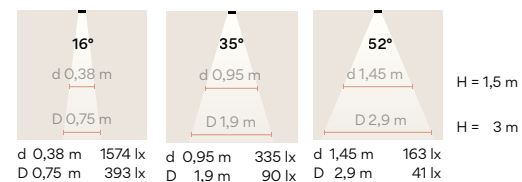



The Bind Solo collection incorporates a range of independent elements that can be fitted directly to the ceiling, including spots, downlights and general lighting fixtures. This combination of functional lighting with decorative pendants means designers can create made-to-measure lighting solutions for moods and uses within the same space.







## Wide Accent Downlight

For softer contrasts and a more diffuse lighting effect, Bind Solo's Wide Accent Downlight floods the space from above, thanks to a generous diameter and wider gradient of light.

- 11 Black (NCS S 8500-N)
- 24 Beige M1 (NCS S 2005-Y50R)

Lens: PC- Polycarbonate  
Body: Aluminum  
Ceiling support: Aluminum

### LED Colour Temperature

Static White  
2700 K - 1256 lm  
3000 K - 1313 lm  
3500 K - 1360 lm  
12,4W

Tunable White (1800 K - 4000 K)  
571 lm - 895 lm  
8,9W

CRI>90

### Control

Analog: Push  
Digital: DALI-2\*; DALI-2 DT8\*  
Smart: Casambi

\*DALI-2 products are compatible (via a designated gateway) with all ProtoPixel dynamic-light solution products.

### Electrical connection

Surface (Driver included)

Updated detailed spec sheets on [vibia.com](http://vibia.com)

6700 Medium  
6702 Wide

Ø 18,5 cm

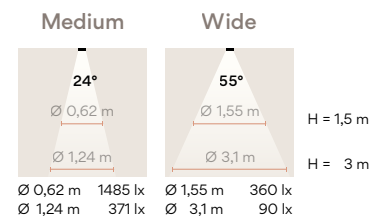

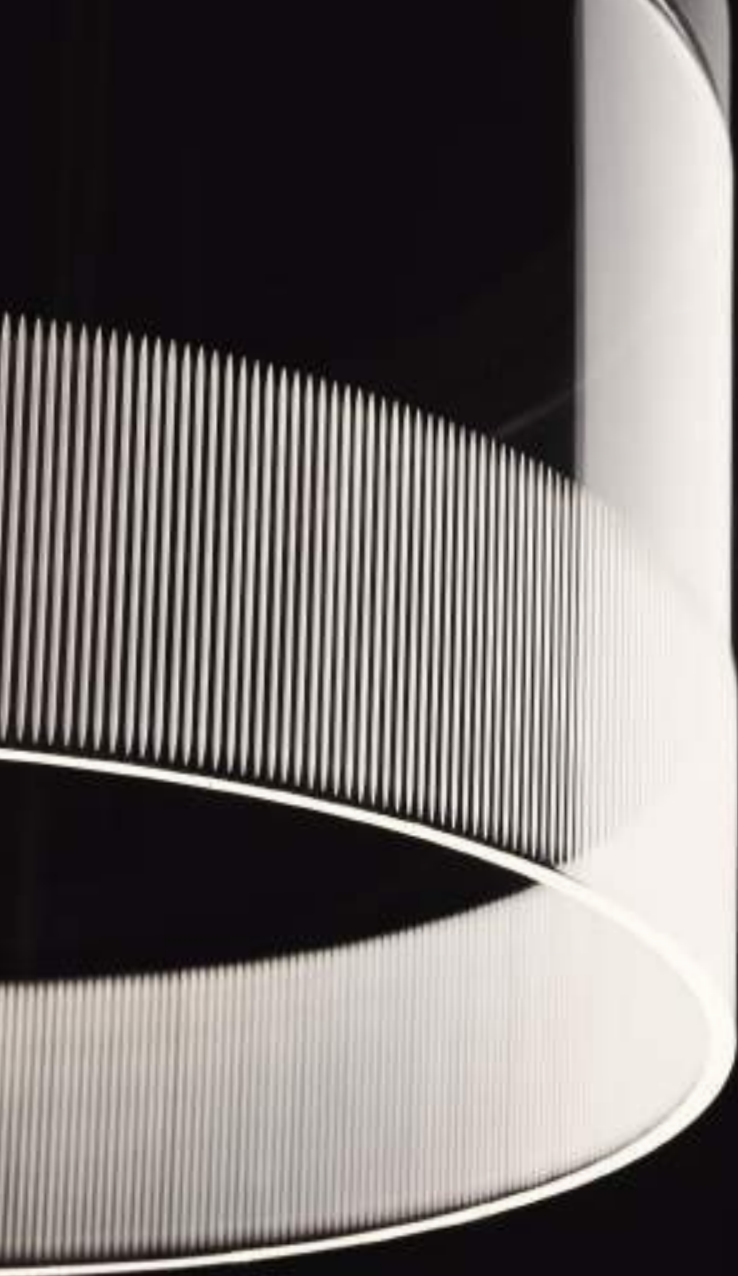

# Guise

Design by Diez Office.

Crafted of precision-cut glass and embedded with a row of recessed LEDs, Guise explores the relationship between light and transparency. The light inside the glass appears invisible, while the delicately engraved surface generates a beautiful diffusion.

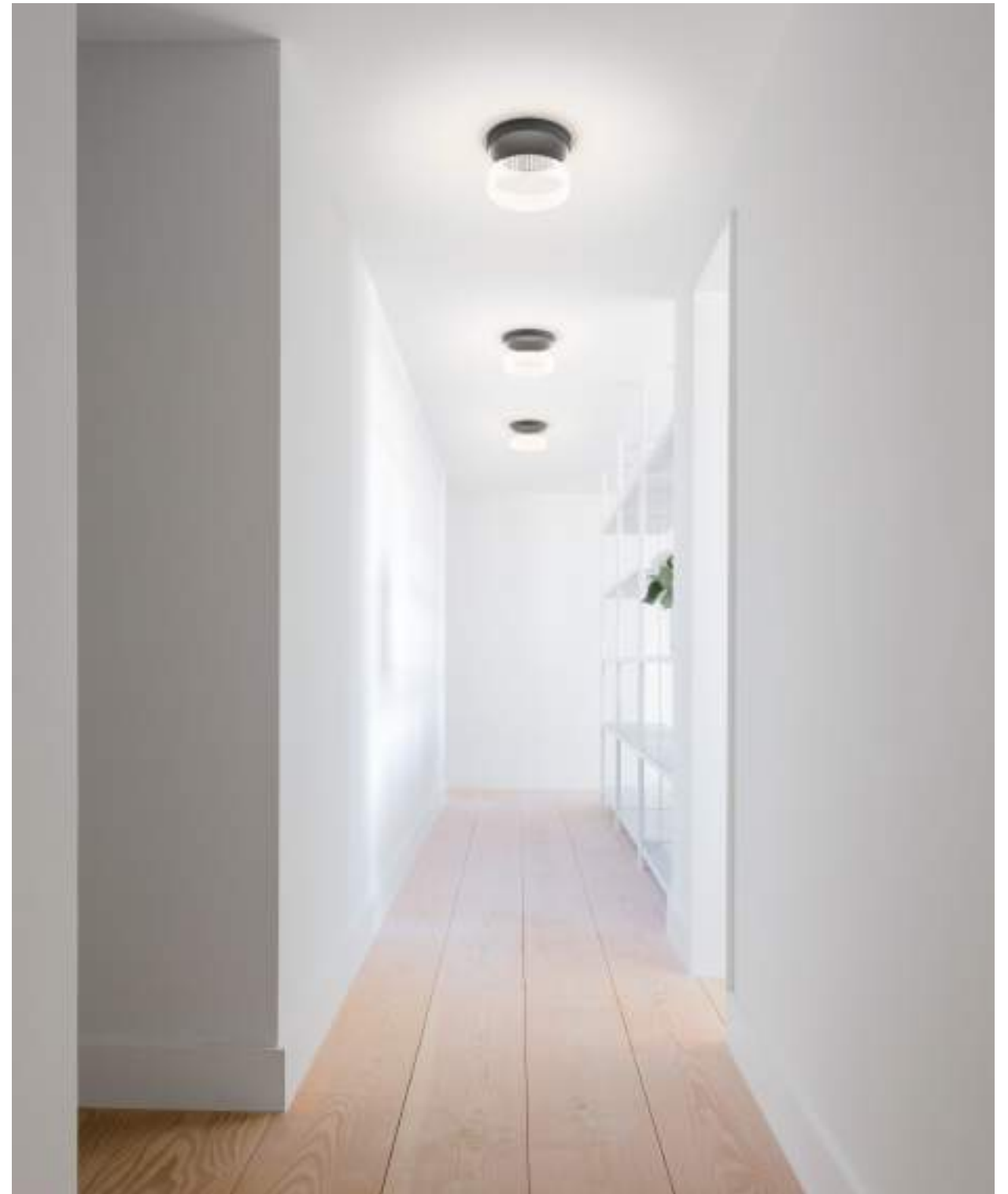



The Guise ceiling light is surface-mounted and available in two sizes. Crafted of precision-cut borosilicate glass, light emanates from the tube while the source remains hidden. When turned on it becomes a luminous hypnotic presence; turned off, the transparent quality of the glass lends an airy sensibility.

● 18 Graphite (ADAPTA RF9913WX)

Diffuser: Borosilicate  
Body: Aluminum

**LED Colour Temperature**  
3000 K  
CRI>90

**Control**  
Analog: Push; 1-10V  
Digital: DALI-2  
Smart: Casambi

**2292**

Ø 25 cm



**2298**

Ø 40 cm

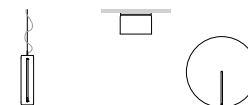

# Funnel



A gentle presence with a distinctly sculptural form, Funnel is a study in materiality, light and space.





As its name suggests, light seems to flow freely from the smooth curve of this ceiling fixture. Its sculptural form conceals an LED light source behind the cap. Light is reflected back into the funnel, creating a flood of indirect, ambient illumination. The collection can be mounted individually or as a collection for greater visual impact.

- 10 White ( NCS S 0300-N)
  - 36 Soft pink (NCS S 1010-Y50R)
  - 47 Green L1 (NCS S 4005-G80Y)
- Additional finish only for Ref. 2012, 2013
- 51 Gold leaf (Gold)

Shade: Aluminum  
Reflector: Aluminum  
Support: Steel

**LED Colour Temperature**  
2700 K; 3000 K; 3500 K  
CRI>80; CRI>90

**Control**  
Analog: On/Off; Push; 1-10V  
Digital: DALI-2  
Smart: Casambi

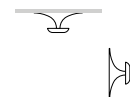

# Structural



Design by Arik Levy.

Structural features cubic forms paired with slender metal rods that both join and separate its volumes. Deconstructing the source, it casts light in unexpected places, creating points of light connected in space.







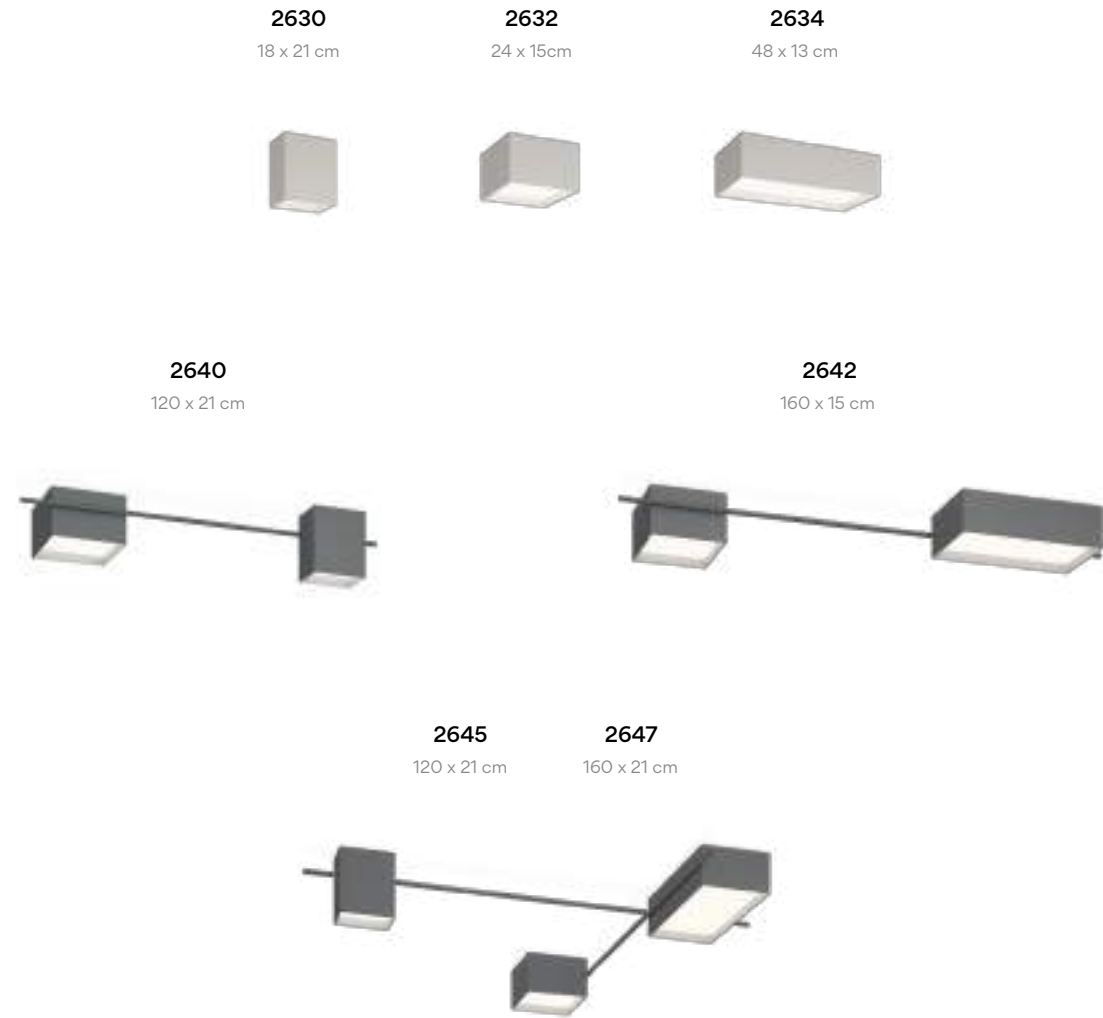

Through the combination of direct and indirect lighting, Structural bathes ceilings with an intense lighting effect. Different cubic volumes meet and expand, its adaptable nature providing flexible solutions while its geometric form maintains a sense of order.

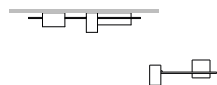

- 15 Grey L2 (NCS S 2500-N)
  - 21 Black Grey (NCS S 7000-N)
- Finish customization  
(Available options: Vibia colour palette)
- Diffuser: PC- Polycarbonate  
Main body: Aluminum  
Structures: Aluminum

**LED Colour Temperature**  
Static White  
2700 K; 3000 K; 3500 K  
Tunable White (2200 K - 4000 K)  
CRI>90

**Control**  
Analog: 1-10V  
Digital: DALI-2; DALI-2 DT8  
Smart: Casambi



Vibia's general lighting, spot accent and downlight luminaires include the option of tunable white. Combining these zenithal tunable white lights with the rest of the diffused and indirect lighting effects of Vibia's portfolio, you can design the perfect scene for every moment and use.



**Tunable White (2200K – 4000K)**  
Tunable white lighting option allows for comprehensive temperature regulation depending on the atmosphere of every scene.

**Static White 2700K; 3000K; 3500K**  
You can select the static white option that fits best with the desired ambience.

Contact Vibia Support Service at [vibia.com](http://vibia.com) for any kind of assistance or recommendation when designing an atmosphere of wellbeing, or if you require support with control system approach.

# Spa

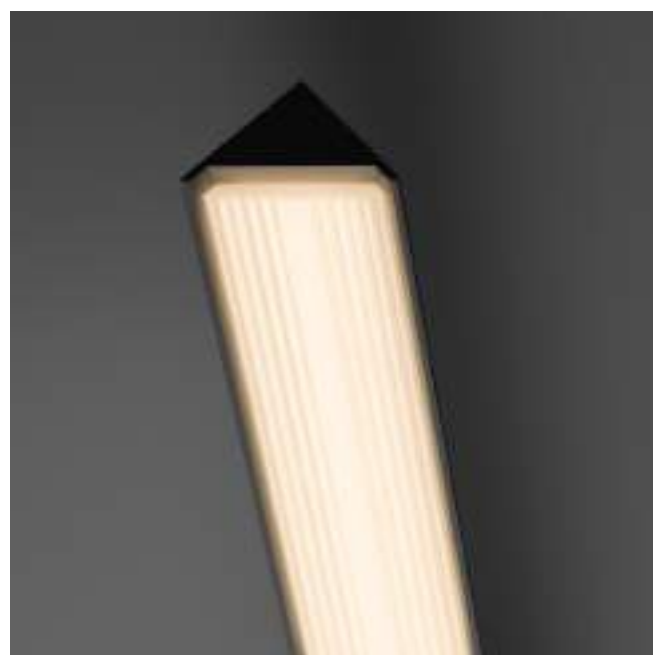

Design by Ramos & Bassols.

Spa is the perfect lighting solution for any wellness space. From public dressing rooms, restaurants and spas, to private kitchens, corridors and bathrooms, its graceful simplicity and linear form allow for seamless integration within a variety of humid interiors.



Multiple luminaires can be positioned in a row to illuminate up to six metres of wall or ceiling space from a single point of connection.



WALL & CEILING



**5975**

121 x 4,7 x 6,5 cm



**5977**

201 x 4,7 x 6,5 cm



**5979**

301 x 4,7 x 6,5 cm



WALL & CEILING



**5981**

253 x 4,8 x 6,6 cm



**5983**

413 x 4,8 x 6,6 cm



**5985**

613 x 4,8 x 6,6 cm



Spa is an adaptable system of linear LEDs that allows for limitless compositional freedom. From intimate corners for personal wellbeing to functional spaces designed for general wellness, Spa's minimalist form and accommodates a range of atmospheres.

- 11 Black (NCS S 8500-N)
- 23 Warm White (NCS S 0502-Y50R)
- 25 Beige D1 (NCS S 4005-Y50R)

Profile and canopy: Aluminum  
Diffuser: PMMA



**LED Colour Temperature**  
2700 K; 3500 K  
CRI>90

**Control**  
Analog: 1-10V  
Digital: DALI-2  
Smart: Casambi (Remote)

IP44



# Up



Design by Ramos & Bassols.

Inspired by the neoclassical cornice, Up's geometric form protrudes from the ceiling with a quiet elegance. Its broad flat diffuser and refined rim create the illusion of daylight passing through an opening in the ceiling.



With a depth of merely 7 centimeters, the surface-mounted aluminum fixture adds an understated, yet distinctive design element.

- 18 Graphite (RAL 7016)
- 93 White (RAL 9016)

Finish customization  
(Available options: Vibia colour palette)

Diffuser: PC- Polycarbonate  
Body: Aluminum  
Ceiling support: Steel

**LED Colour Temperature**

Static White  
2700 K  
Tunable White (2200K - 4000K)  
CRI>90

**Control**

Analog: Push; 1-10V  
Digital: DALI-2; DALI-2 DT8  
Smart: Casambi

4440

Ø 50 cm



4442

Ø 77 cm



4460

106 x 106 cm



4452

73 x 121 cm



4454

64 x 64 cm

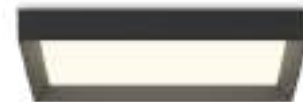

Vibia's general lighting, spot accent and downlight luminaires include the option of tunable white. Combining these zenithal tunable white lights with the rest of the diffused and indirect lighting effects of Vibia's portfolio, you can design the perfect scene for every moment and use.



**Tunable White (2200K - 4000K)**  
Tunable white lighting option allows for comprehensive temperature regulation depending on the atmosphere of every scene.

**Static White 2700K**

Contact Vibia Support Service at [vibia.com](http://vibia.com) for any kind of assistance or recommendation when designing an atmosphere of wellbeing, or if you require support with control system approach.

# Puck



Design by Jordi Vilardell.

Inspired by the iconic circle motif, Puck's simple, spherical forms can be superimposed on top of one another, lending the whole an organic sensibility.

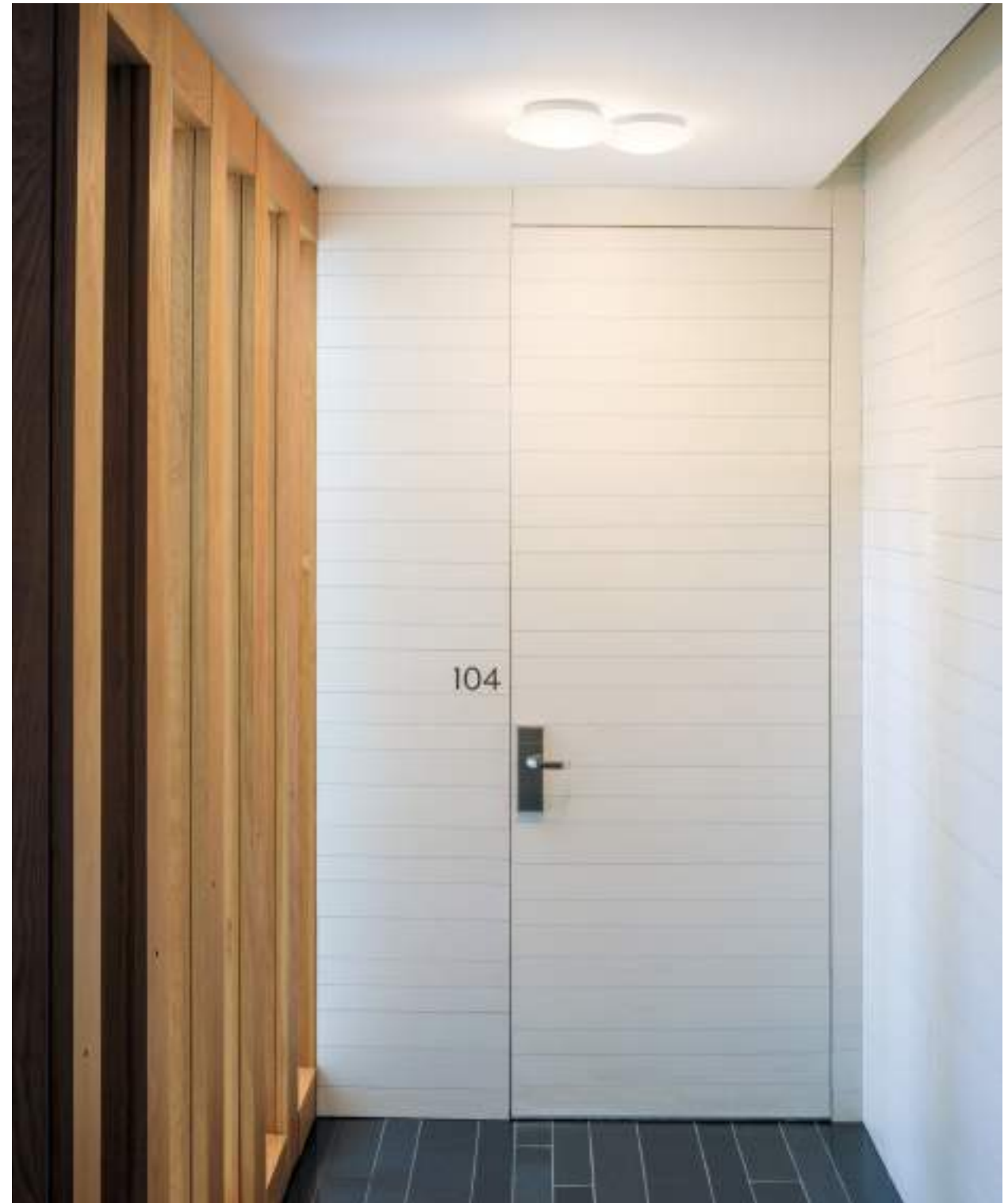



The Puck collection offers users a versatile ceiling light defined by its strong formal expression and warm illumination thanks to its LED light source and blown-glass diffuser. Puck combines a series of models of different compositions, all of which work off a single electrical point connection, using circles as their central leitmotif.

● 03 White (RAL 9016)

**Control**  
Analog: On/ Off

Canopy: Aluminum  
Diffuser: Blown-glass

All versions require just one electrical connection.  
Surface mounted

**LED Colour Temperature**

2700 K  
CRI>90



**5410**

24,4 x 6,6 cm



**5412**

27,2 x 7,7 cm



**5430 5432**

46,7 x 38 cm



**5435 5437**

56,8 x 49,2cm

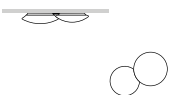



# Tube Free



Design by Ichiro Iwasaki.

With the Tube ceiling collection, Ichiro Iwasaki endeavours to create a lighting system capable of forming distinctive expressions by reconfiguring the different constituent parts. By combining three different diameter shades, six colour tones and a rhythm of differing heights, Tube creates a unique landscape of luminaires overhead.





Built-in

6095

Ø 22 cm



6100

Ø 28,5 cm



6105

Ø 41 cm



- 10 White (NCS S 0300-N)
- 15 Grey L2 (NCS S 2500-N)
- 16 Grey M1 (NCS S 4500-N)
- 21 Black Grey (NCS S 7000-N)
- 24 Beige M1 (NCS S 2005-Y50R)
- 37 Terra Red (NCS S 4040-Y70R)

**LED Colour Temperature**

2700 K; 3000 K; 3500 K  
CRI>90

**Control**

Analog: Push; 1-10V  
Digital: DALI-2  
Smart: Casambi

Diffuser: PC- Polycarbonate  
Led support: Aluminum  
Shade: Aluminum  
Canopy: Steel



# Bigger



Design by La Invisible.

Bigger serves as statement lighting without overbearing the space it occupies. Radiating with profuse light which cascades down from above, its impressive scale and soothing geometry introduce a striking new dimension.





- 23 Beige L1 (NCS S 0502-Y50R)
- 24 Beige M1 (NCS S 2005-Y50R)
- 37 Terra Red (NCS S 4040-Y70R)
- 53 Green M1 (NCS S 6005-G80Y)

Body: Aluminum  
Shade: Aluminum  
Diffuser: PC- Polycarbonate

**LED Colour Temperature**

Static White  
2700 K; 3500 K  
Tunable White (2200K - 4000K)  
CRI>90

**Control**

Analog: Push; 1-10V  
Digital: DALI-2; DALI-2 DT8  
Smart: Casambi

Updated detailed spec sheets  
on [vibia.com](http://vibia.com)



Pg 176 VOL 1 Pg 262 VOL 2



Vibia's general lighting, spot accent and downlight luminaires include the option of tunable white. Combining these zenithal tunable white lights with the rest of the diffused and indirect lighting effects of Vibia's portfolio, you can design the perfect scene for every moment and use.



**Tunable White (2200K – 4000K)**  
Tunable white lighting option allows for comprehensive temperature regulation depending on the atmosphere of every scene.

**Static White 2700K; 3500K**  
You can select the static white option that fits best with the desired ambience.

Contact Vibia Support Service at [vibia.com](http://vibia.com) for any kind of assistance or recommendation when designing an atmosphere of wellbeing, or if you require support with control system approach.



Wall

# Wall

|                      |                          |                   |
|----------------------|--------------------------|-------------------|
| Alpha<br>316         | North<br>330             | Set<br>274        |
| Dots<br>242          | Offset<br>348            | Spa<br>232        |
| Dots<br>Glass<br>252 | Origami<br>312           | Sticks<br>340     |
| Funnel<br>300        | Palma<br>256             | Structural<br>268 |
| Guise<br>288         | Pin<br>262               | Suite<br>304      |
| Halo<br>336          | Plusminus<br>Solo<br>216 | Tempo<br>226      |
| I.Cono<br>308        | Puck<br>320              | Top<br>210        |
| Kontorno<br>278      | Puck<br>Wall Art<br>324  |                   |
| Musa<br>296          |                          |                   |



# Top

Design by Ramos & Bassols.

Soft, spherical shapes and a warm luminescence characterize the Top collection. Its glowing epicenter is encircled by a larger ring, framing the light within its pure geometry.







1170  
Ø 90 cm



1154  
Ø 17 cm



1160  
Ø 60 cm



1155  
Ø 40 cm

- 10 White (NCS S 0300-N)
- 36 Soft Pink (NCS S 1010-Y50R)
- 40 Blue L1 (NCS S 3010-B)
- 47 Green L1 (NCS S 4005-G80Y)

**LED Colour Temperature**  
2700 K; 3500 K  
CRI>90

**Control**  
Analog: On/ Off; Push; 1-10V  
Digital: DALI-2  
Smart: Casambi

Body: Aluminum  
Ref. 1170  
Diffuser: Triplex Opal Glass

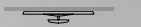

# Plusminus Solo

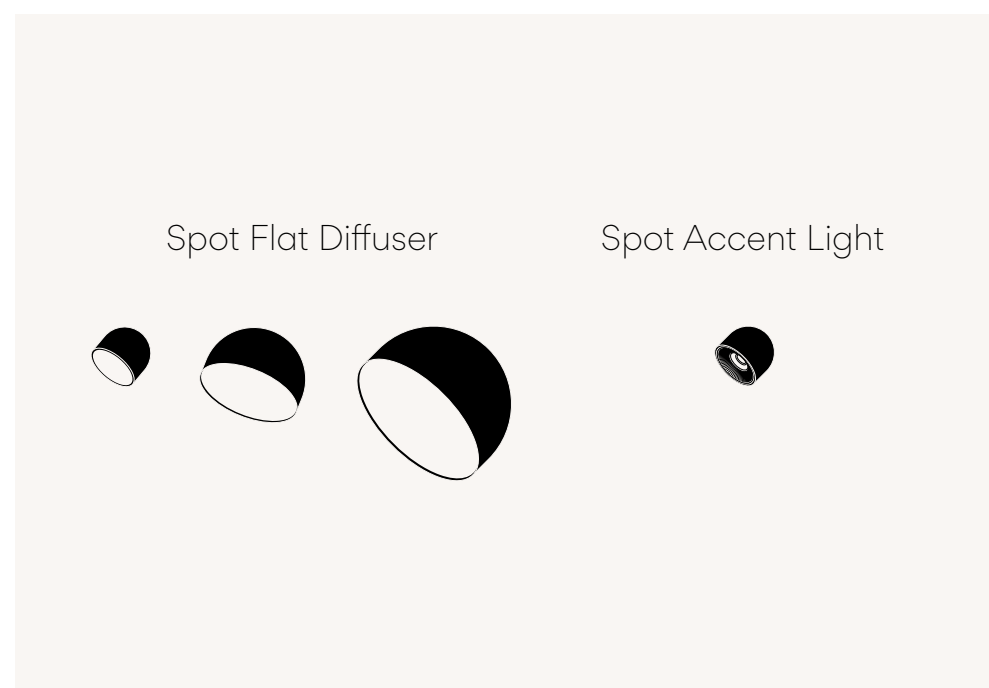

Design by Diez Office.

Plusminus Solo introduces a collection of versatile semi-spherical luminaires that adapt to the surrounding space. Easily adjustable, the Plusminus wall range features semi-spherical directed flat diffusers in different sizes, as well as an accent spotlight for more precise illumination.





To see Plusminus collection  
go to page 272 VOL 1



Available in five elegant finishes and mounted as desired, the Plusminus Solo wall range is suitable for functional purposes, such as illuminating a transitional area by bathing a wall with soft light, as well as shaping comfortable scenes through a unique blend of diffuse and accented lighting. Combined with Plusminus Solo floor, table and ceiling luminaires the possibilities are endless.





- 11 Black (NCS S 8500-N)
- 24 Beige M1 (NCS S 2005-Y50R)
- 37 Terra Red (NCS S 4040-Y70R)
- 42 Blue M1 (NCS S 5010-B10G)
- 53 Green M1 (NCS S 6005-G80Y)

Body: Aluminum  
Diffuser: PC- Polycarbonate

**LED Colour Temperature**

Accent  
2700 K - 941 lm  
3000 K - 987 lm  
3500 K - 1022 lm  
7,2W

Flat diffuser  
LED 2700 K; 3000 K; 3500 K  
CRI>90

**Control**

Analog: On/ Off; Push; 1-10V  
Digital: DALI-2  
Smart: Casambi

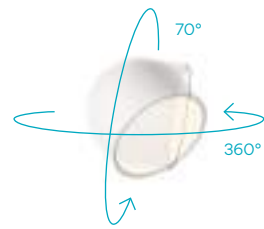

Updated detailed spec sheets on [vibia.com](http://vibia.com)

**SPOTLIGHT - ACCENT**

| Narrow                            | Medium                           | Wide                              |
|-----------------------------------|----------------------------------|-----------------------------------|
| 15°                               | 33°                              | 49°                               |
| ø 0,2 m                           | ø 0,9 m                          | ø 0,69 m                          |
| ø 0,4 m                           | ø 1,8 m                          | ø 1,37 m                          |
| H = 1,5 m                         |                                  |                                   |
| H = 3 m                           |                                  |                                   |
| ø 0,2 m 1240 lx<br>ø 0,4 m 310 lx | ø 0,9 m 851 lx<br>ø 1,8 m 213 lx | ø 0,69 m 307 lx<br>ø 1,37 m 77 lx |

**Remote version Built-in**

**SPOTLIGHT**

Accent  
**6330** Narrow  
**6331** Medium  
**6332** Wide  
ø 10 cm



Flat diffuser  
**6333**  
ø 10 cm



**SEMISPHERE**

Flat diffuser  
**6335**  
ø 20 cm



Flat diffuser  
**6340**  
ø 30 cm



**Plug version Surface**

**SPOTLIGHT**

Accent  
**6361** Medium  
ø 10 cm



Flat diffuser  
**6363**  
ø 10 cm



Flat diffuser  
**6365**  
ø 20 cm



Flat diffuser  
**6370**  
ø 30 cm





# Tempo



Design by Lievore Altherr.

The Tempo collection reclaims our collective memory of light, distilling lighting archetypes into three basic forms: the disc, the diamond and the milk glass oval explore the interplay of opacity, translucence and transparency.





Fusing contemporary style and classic design, the collection is characterised by lean lines and a long adjustable arm that extends out from its vertical base.

The opaline diamond projects a diffused light of a romantic quality, filling a space with its inviting glow. An evolution of the classic bistro globe, the oval diffuser hangs gracefully in the air, its translucency introducing an air of tranquillity. Converting the traditional bulb into a brilliant bubble, the reflector disk embraces an industrial aesthetic. Featuring a flat graphite-coloured plate, light is reflected downwards for a compelling effect.

Ref.  
5757, 5759, 5761, 5763,  
5765, 5767. Recessed  
dimmable driver.



Ref.  
5756, 5758, 5760, 5762,  
5764, 5766. Push dimmer  
on the cable. With plug.





- 18 Graphite (ADAPTA RF 9913 WX)
- 37 Terra Red (NCS S 4040-Y70R)
- 58 Cream (RAL 7044)
- 62 Green (NCS S 3010-G20Y)

Diffuser: Blown-glass  
 LED support: Aluminum  
 Structures: Steel  
 Shade: Aluminum

**LED Colour Temperature**

2700 K  
 CRI>90

**Control**

Analog: Push; 1-10V  
 Digital: DALI-2  
 Smart: Casambi

**5756 5757**  
 122,5 x 80 cm



**5758 5759**  
 116,5 x 80 cm



**5760 5761**  
 120 x 80 cm



**5762 5763**  
 42,5 x 140 cm



**5764 5765**  
 36,5 x 140 cm



**5766 5767**  
 40 x 140 cm

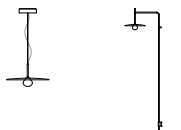

# Spa

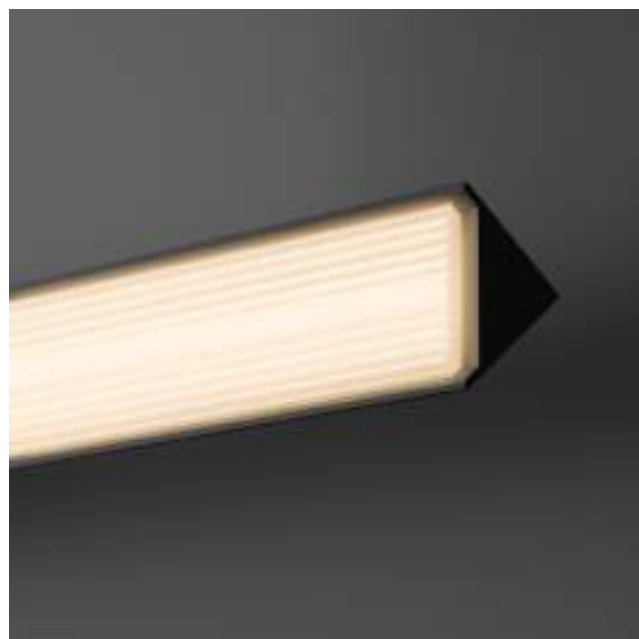

Design by Ramos & Bassols.

Spa is the perfect lighting solution for any wellness space. From public dressing rooms, restaurants and spas, to private kitchens, corridors and bathrooms, its graceful simplicity and linear form allow for seamless integration within a variety of humid interiors.





The diffuser provides diffuse, glare-free, front lighting, ideal for creating an intimate atmosphere.



### Vanity light

Ideal as a bathroom mirror light fixture, Spa can be positioned at an angle to send diffuse, ambient lighting in the desired direction.

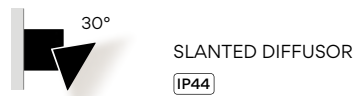

IP44. Spa can be wiped down with a wet cloth for easy maintenance

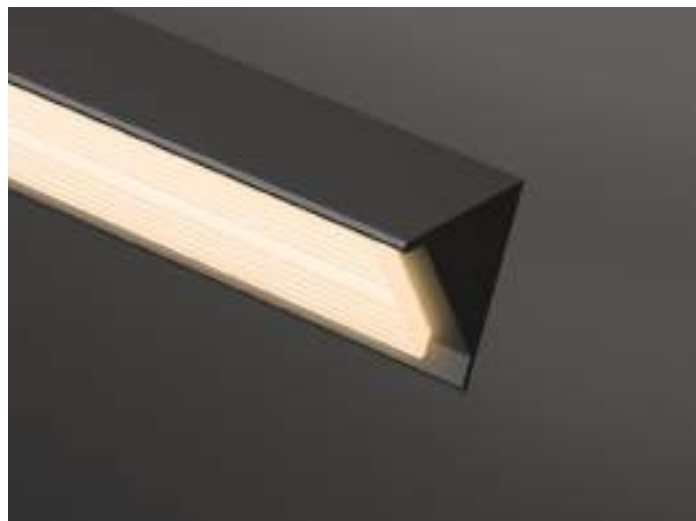

Each luminaire is separated from the wall by a single aluminium support and connects to a simple terminal, invisible from the front, which lends a sense of weightlessness and essentiality to the design.

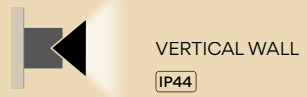

WALL & CEILING



**5975**

121 x 4,7 x 6,5 cm



**5977**

201 x 4,7 x 6,5 cm



**5979**

301 x 4,7 x 6,5 cm



**5981**

253 x 4,8 x 6,6 cm



**5983**

413 x 4,8 x 6,6 cm



**5985**

613 x 4,8 x 6,6 cm



WALL VANITY LIGHT  
(slanted diffusor)



**5987**

121 x 7,3 x 5,3 cm



**5989**

201 x 7,3 x 5,3 cm



**5991**

301 x 7,3 x 5,3 cm



VERTICAL WALL



**5995**

6,6 x 4,7 x 212 cm



**5993**

6,6 x 4,7 x 132 cm

- 11 Black (NCS S 8500-N)
- 23 Warm White (NCS S 0502-Y50R)
- 25 Beige D1 (NCS S 4005-Y50R)

Profile and canopy: Aluminum  
Diffuser: PMMA

LED Colour Temperature

2700 K; 3500 K  
CRI>90

Control

Analog: 1-10V  
Digital: DALI-2  
Smart: Casambi (Remote)

IP44

Suitable for wet location





# Dots



Design by Martín Azúa.

This small scale wall sconce in the form of simple, circular dots delivers high visual impact through a range of lighting effects. Seamlessly connecting a space with an intimate landscape of beams and halos, the collection creates a melody of light like a composition of musical notes in concert with one another.





Its compact shape and coloured lacquer or natural wood finishes mean Dots can be easily integrated into any space.

4662 item with on-off switch on the back plate

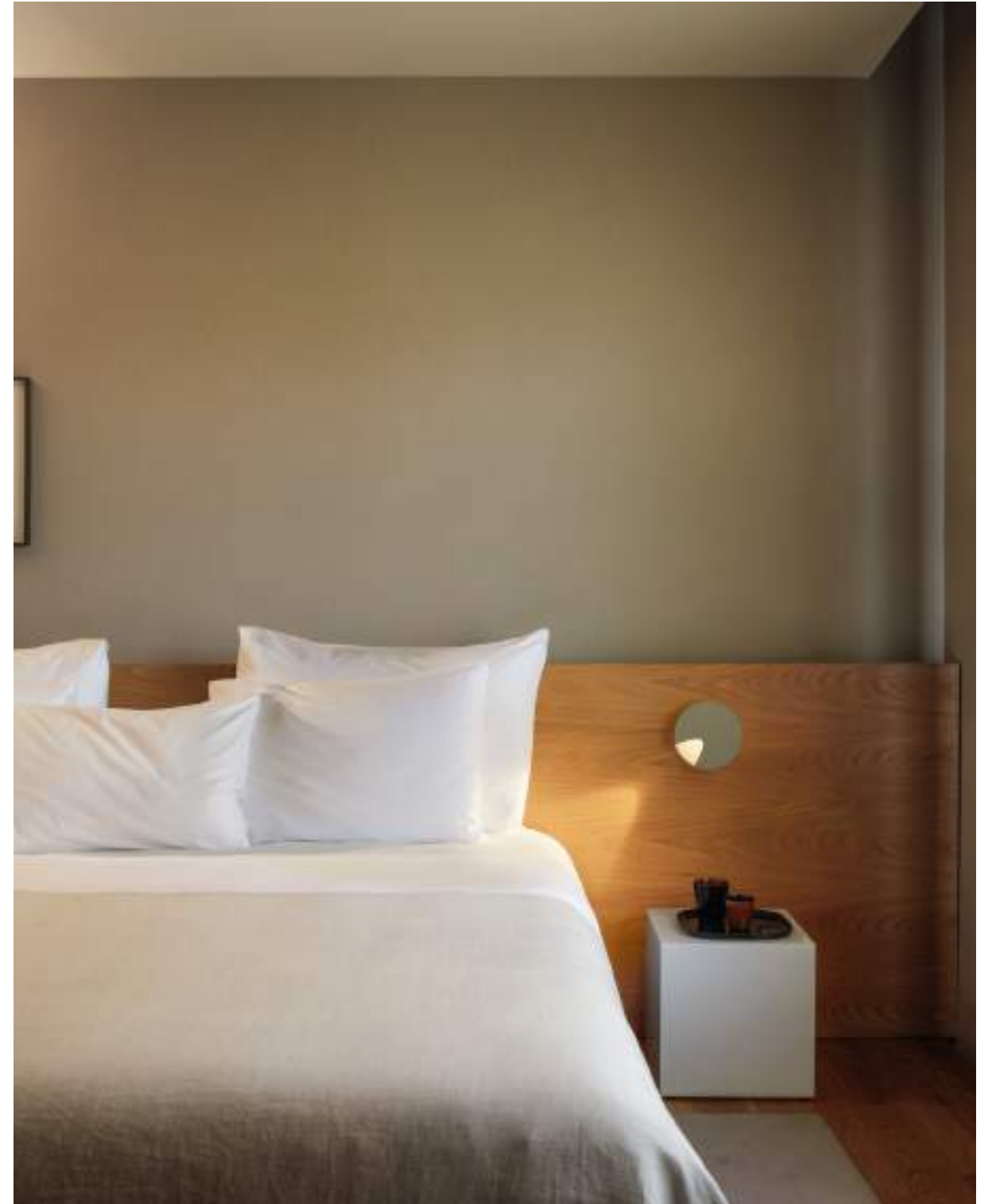

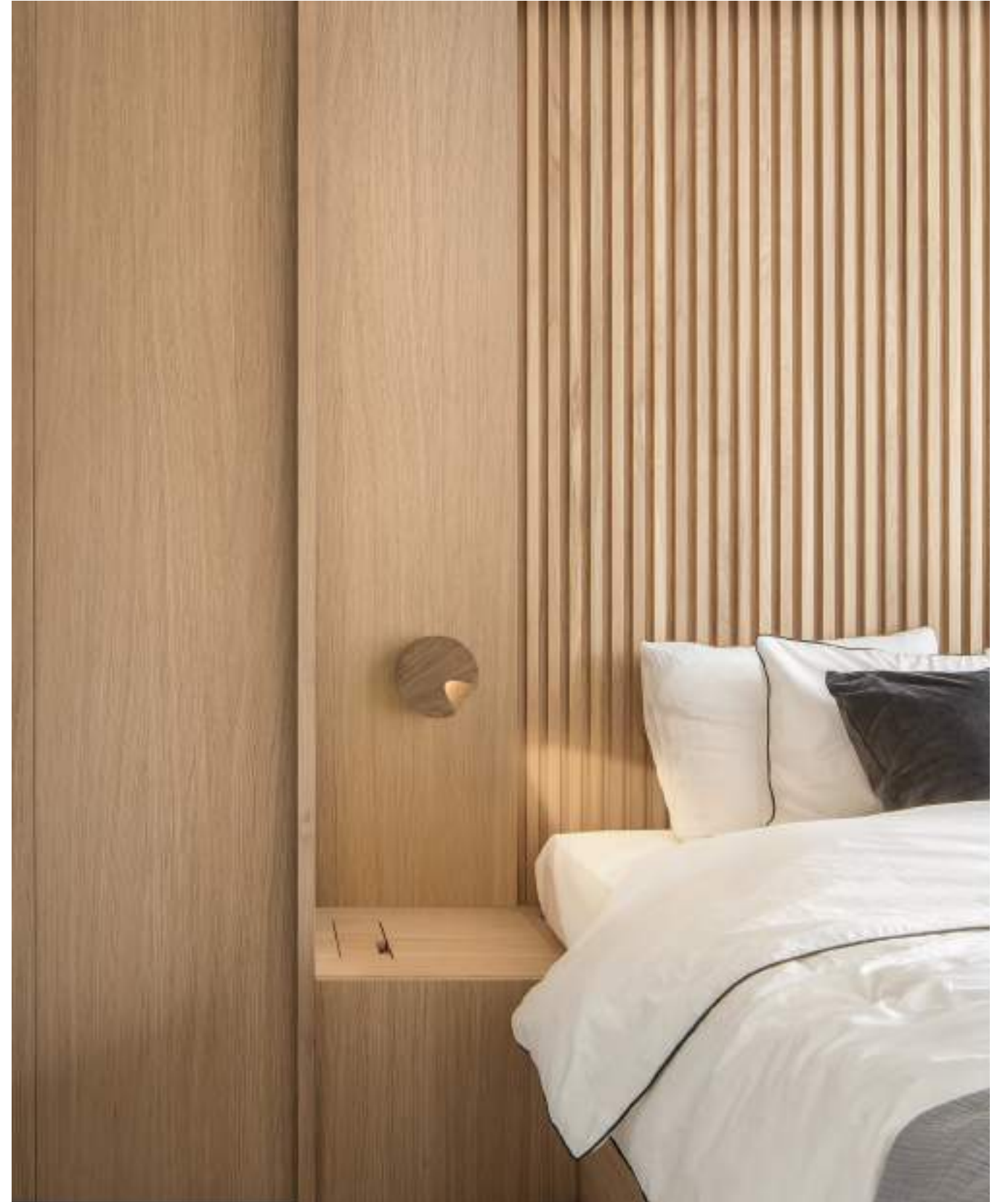



Deployed alone like a sparkling jewel or in combination to create a glowing galaxy, Dots luminaires provide personalised lighting solutions for a range of uses: task lighting, graphic, directional light, and diffuse, ambient illumination.



“Dots is a simple, versatile lighting system that offers many different solutions in one collection. If we forget the idea that wall lamps are boring, we can suddenly start playing with material, colours and lighting effects in group or individually to create comfortable atmospheres”.

Martín Azúa

- 13 Grey L1 (NCS S 1000-N)
- 27 Sand (NCS S 1505-Y50R)
- 37 Terra Red (NCS S 4040-Y70R)
- 47 Green L1 (NCS S 4005-G80Y)
- 82 White oak
- 83 American walnut

Body: ABS or Wood  
 Diffuser: PC- Polycarbonate  
 Canopy: Aluminum

**LED Colour Temperature**  
 2700 K; 3500 K  
 CRI>90

**Control**  
 Analog: On/ Off ; TRIAC; 1-10V  
 Digital: DALI-2

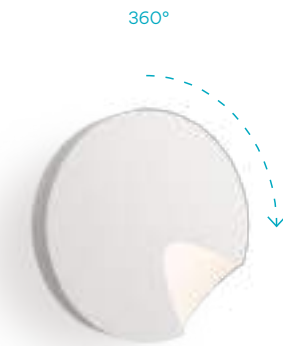

Ajustable: 360° turn.  
 4662: On-off switch on the back plate.

**4660 - 4662**  
 Ø 17,5 cm



Once installed position is fixed  
 and cannot be adjusted.

**4665**  
 Ø 17,5 cm



Ajustable: 360° turn.

**4670**  
 Ø 17,5 cm



**4675**  
 Ø 17,5 cm



# Dots Glass



Design by Martín Azúa.

The Dots collection introduces a sleek new diffuser. Sheathed in layers of transparent optical glass, Dots Glass generates a warm, 360-degree glow with a pulsating ambient effect.





● 10 White (NCS S 0300-N)

Body: Aluminum  
Diffuser: Optical Glass

**LED Colour Temperature**  
2700 K; 3500 K  
CRI>90

**Control**  
Analog: On/ Off; 1-10V  
Digital: DALI-2  
Smart: Casambi (Remote)

IP66



**4680**  
Ø 20 cm

# Palma



Design by Antoni Arola.

The interior ambience takes on a life of its own with Palma; an unexected design that accommodates greenery along its axis.







Palma consists of hand blown glass spheres joined together by a contemporary aluminium structure. Available in vertical and horizontal orientations and a choice of one, two or three spheres, the sconces and plantings can be combined in an array of different compositions to span a broad stretch of wall or climb upward towards the ceiling.





**3710**  
22 x 55 x 25 cm

**3714**  
22 x 114 x 26 cm

**3716**  
22 x 114 x 26 cm

**3718**  
22 x 187 x 26 cm

● 18 Graphite (ADAPTA RF 9913 WX)

Diffuser: Blown-glass  
Profile: Aluminum  
Planter: PMMA

**LED Colour Temperature**

2700 K  
CRI>90

**Control**

Analog: Push; 1-10V  
Digital: DALI-2

**3700**  
55 x 19 x 25 cm

**3702**  
85 x 22 x 25 cm

**3704**  
120 x 22 x 25 cm

**3706**  
195 x 22 x 25 cm



# Pin

Design by Ichiro Iwasaki.

A timeless proposal from Japanese designer Ichiro Iwasaki, Pin is both classic and contemporary. Characterised by a graceful stem and subtle, functional expression, it is small in scale but with exceptional lighting efficiency.





As a wall lamp, Pin features a striking interplay of geometric forms. Lean, steel lines extend outward, punctuated by a bold, circular base and aluminum dome shades. Whether displayed individually or in customised combinations, Pin functions as abstract wall art as well as a simple reading light.





**1675**  
Ø 10 cm



**1680**  
25 x 39 cm



**1685**  
30 x 70 x 8 cm



**1686**  
30 x 70 x 8 cm



**1690**  
Ø 10 x 40 x 8 cm



**1692**  
Ø 10 x 70 x 8 cm



**1694**  
70 x 40 x 8 cm

- 11 Black (NCS S 8500-N)
- 23 Warm White (NCS S 0502-Y50R)
- 58 Cream (NCS S 2500-Y20R)
- 62 Green (NCS S 3010-G20Y)

Finish customization  
(Available options: Vibia colour palette)

Diffuser: PC- Polycarbonate  
Head: Aluminum  
Rods: Steel  
Base: Zinc Alloy

**LED Colour Temperature**  
2700 K  
CRI>90

**Control**  
Analog: On/ Off

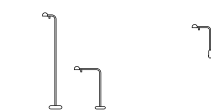

# Structural



Design by Arik Levy.

Structural features cubic forms paired with slender metal rods that both join and separate its volumes. Deconstructing the source, it casts light in unexpected places, creating points of light connected in space.

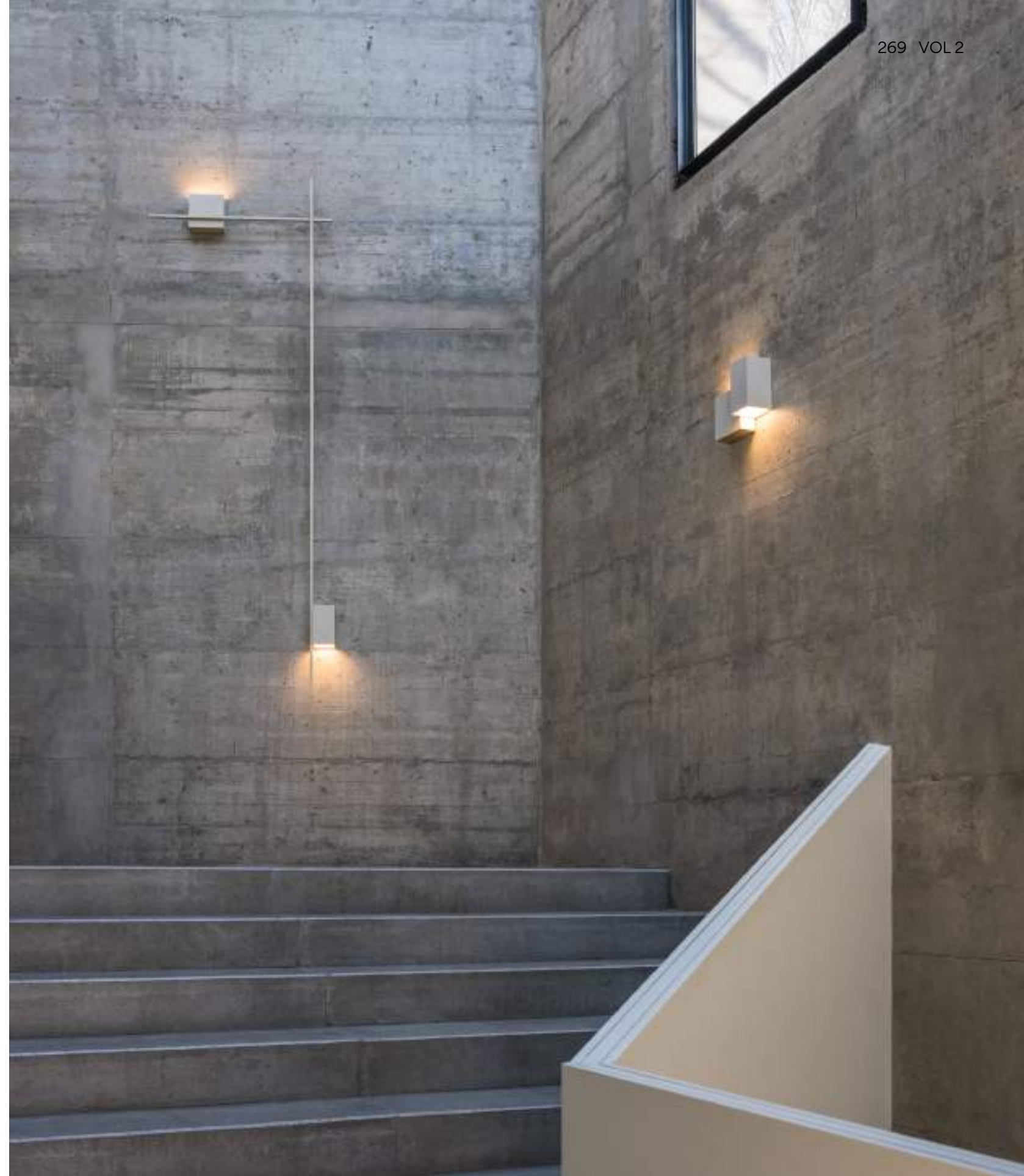





The Structural wall lamp can be combined in various arrangements to integrate with a range of architectural styles and spaces. Marked by lean lines and defined coordinates, it creates glowing sculptural silhouettes. The LED-powered light source is encased in an aluminium box, bathing walls in a bright wash of light without glare.

- 15 Grey L2 (NCS S 2500-N)
- 21 Black Grey D1 (NCS S 7000-N)

Finish customization  
(Available options: Vibia colour palette)

Diffuser: PC- Polycarbonate  
Main body: Aluminum  
Structures: Aluminum

**LED Colour Temperature**  
2700 K; 3000 K; 3500 K  
CRI>90

**Control**  
Analog: 1-10V  
Digital: DALI-2  
Smart: Casambi

**2600**  
16 x 16 cm



**2602**  
26 x 22 cm



**2610**  
120 x 18 x 10 cm



**2612**  
240 x 30 x 10cm



**2615**  
180 x 120 x 10 cm



**2617**  
84 x 240 x 10 cm

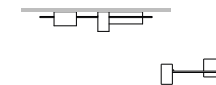



# Set

Design by Xuclà.

Set is a new concept of modular wall sconces that composes light as art onto the walls. During the day Set decorates the wall with a pattern of rectangular elements, but once illuminated it creates a surprising play of lights, shadows and volumes.



**7749**

18 x 10 cm

**7750**

18 x 10 cm

**7751**

30 x 10 cm

**7752**

30 x 10 cm

**7753**

38 x 10 cm

A customised composition of rectangular pieces crafted of an aluminum body and fine borosilicate-glass diffuser, Set both generates and reflects light. It features one fixed component fitted with an LED that casts its light over the other adjustable volumes, each, in turn, emanating elegant rays of light and shadow upwards. The fixture produces an endless array of luminary effects depending on how it's positioned and doubles as dramatic wall art.

- 25 Beige D1 (NCS S 4005-Y50R)
- 93 White (RAL 9003)

Main body: Aluminum  
 Diffuser: Borosilicate glass  
 Lid: PC- Polycarbonate  
 Reflecting bodies: PVC

**LED Colour Temperature**

2700 K; 3500 K  
 CRI>90

**Control**

Analog: 0-10V



# Kontorno



Design by Sebastian Herkner.

Consisting of an elegant linear framework complemented by a cylindrical diffuser or curved reflector, the Kontorno collection envelops the light source it contains, offering diffuse, balanced illumination.





Large-scale glass wall lamp

Pure and refined, Kontorno's cylindrical glass diffuser expresses timeless romanticism with its warm, 360-degree glow.

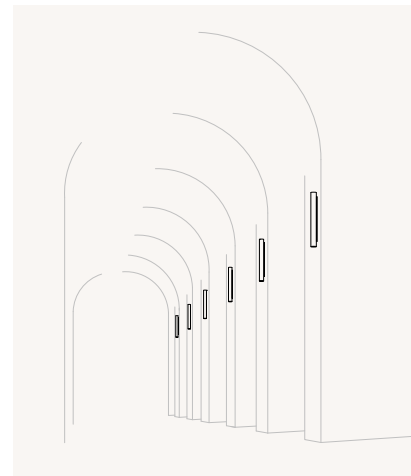

“Kontorno is about simplicity and balance. The light is very poetic and features a frame interacting with different shapes to generate myriad lighting moods and atmospheres.”

Sebastian Herkner.





Glass Shade



6444  
19 x 92 cm



6446  
19 x 122 cm

● 11 Black (NCS S 8500-N)

Glass shade: Opal triplex  
Diffuser: PC- Polycarbonate  
Canopy: Aluminum

**LED Colour Temperature**  
2200 K; 2700 K; 3000 K; 3500 K  
CRI>90

**Control**  
Analog: Push; 1-10V  
Digital: DALI-2  
Smart: Casambi

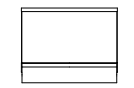



2200 K LED Colour Temperature

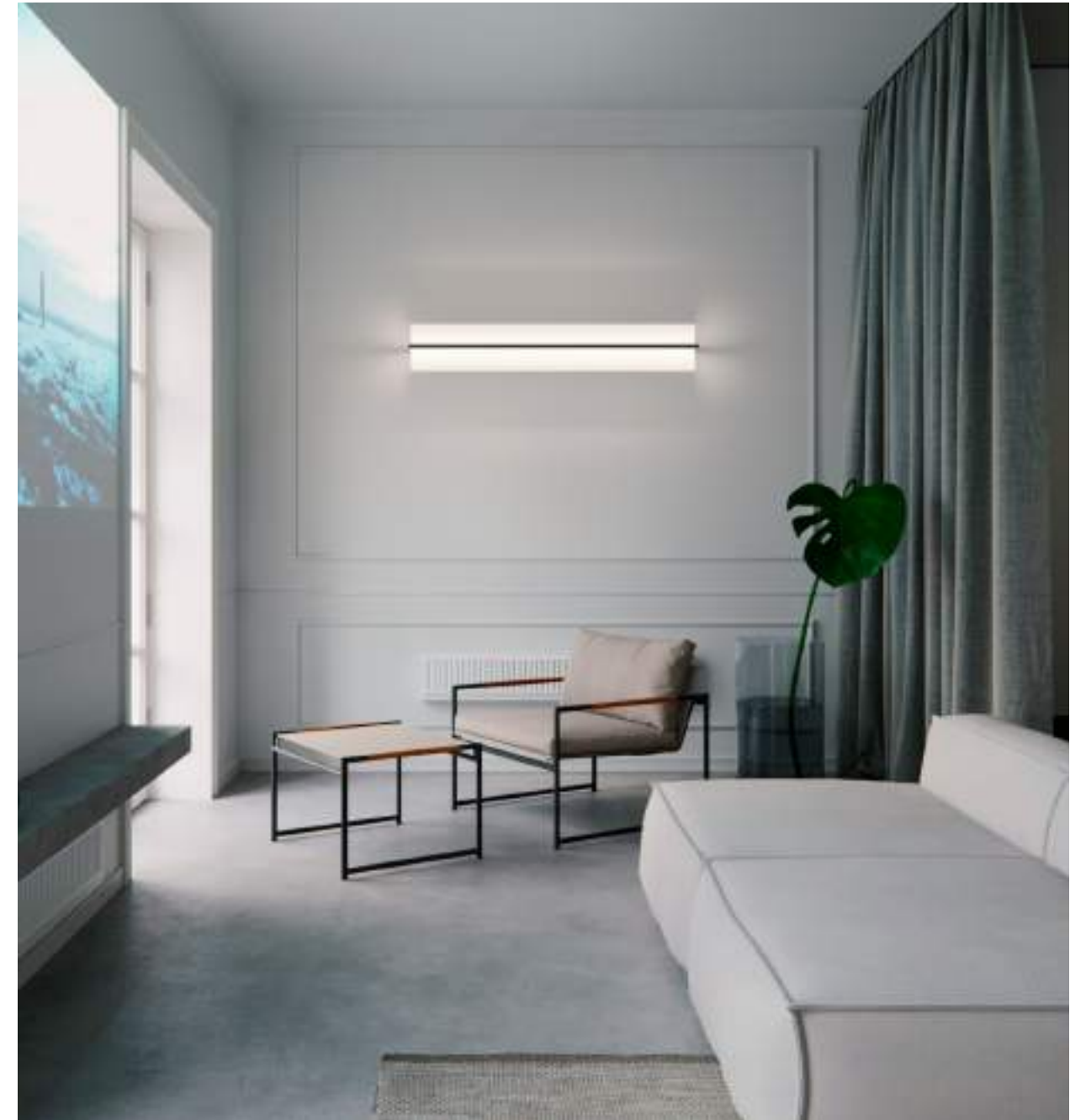

2700 K LED Colour Temperature

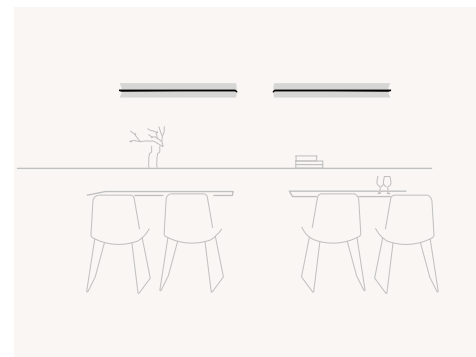



Aluminum Shade



6414  
20 x 92 cm



6416  
20 x 122 cm



6418  
20 x 162 cm

● 11 Black (NCS S 8500-N)

Concave shade: Aluminum  
Diffuser: PC- Polycarbonate  
Structures: Steel  
Canopy: Aluminum



**LED Colour Temperature**  
2200 K; 2700 K; 3000 K; 3500 K  
CRI>90

**Control**  
Analog: Push; 1-10V  
Digital: DALI-2  
Smart: Casambi

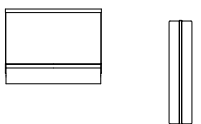

# Guise



Design by Diez Office.

Crafted of precision-cut glass and embedded with a row of recessed LEDs, Guise explores the relationship between light and transparency. The light inside the glass appears invisible, while the delicately engraved surface generates a beautiful diffusion.

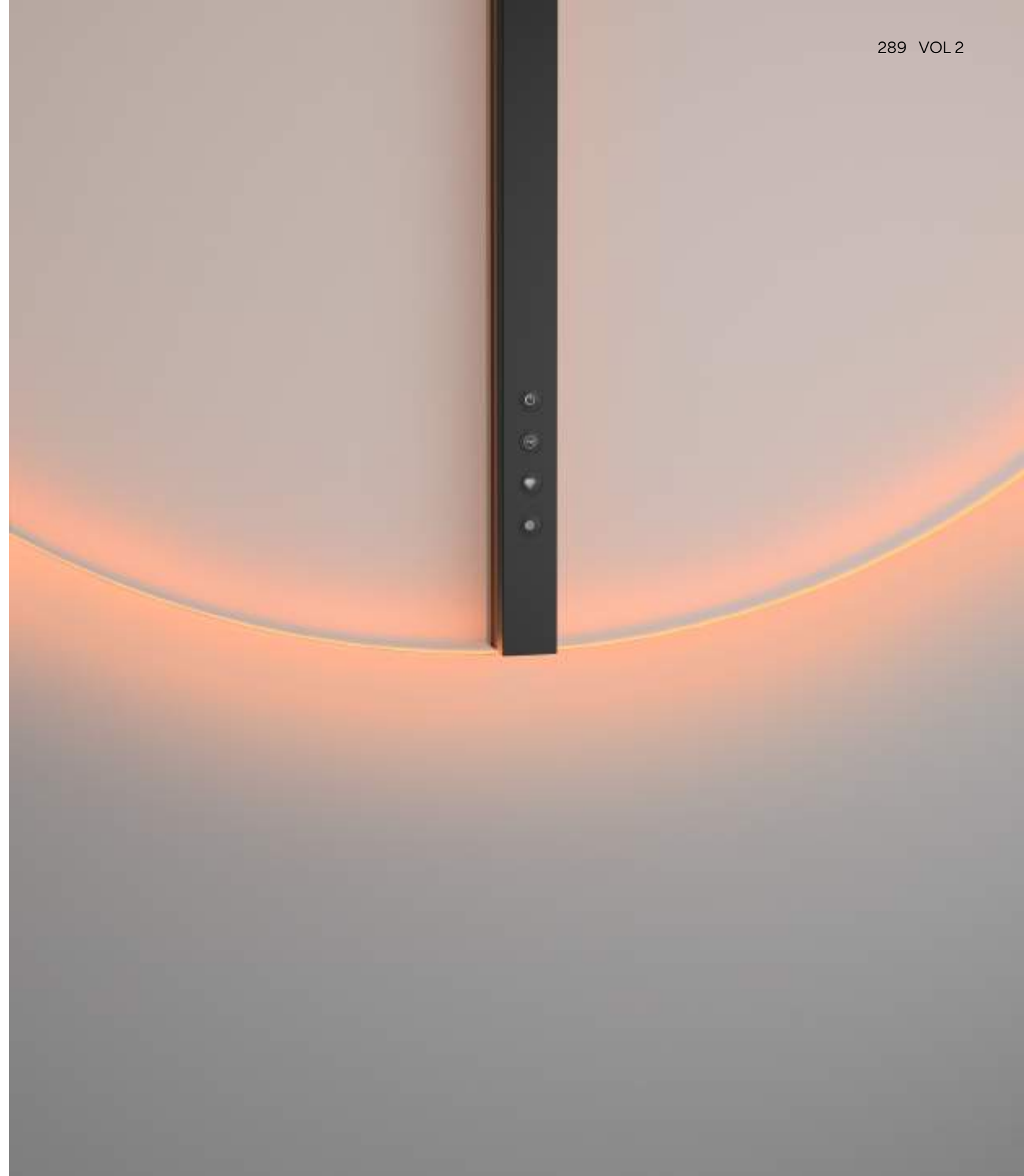



## A source of emotion

Colour is a source of emotion it can instantly set a mood, convey a feeling or generate a sense of wellbeing

Vibia's approach to coloured light invites the use of colour and gradients to create and experience different atmospheres, making them as natural and subtle as possible. Natural light is never mono-tonal. Gradients come in infinite colours.



## Vibia Chromatica colours of light

### Static White

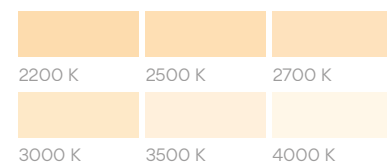

You can select any desired light -white, colour mood or gradient- and intensity manually from the analogic product interface. You can also integrate your selection into the control system for specific scene design and activate it using the Vibia App

### Colour Moods

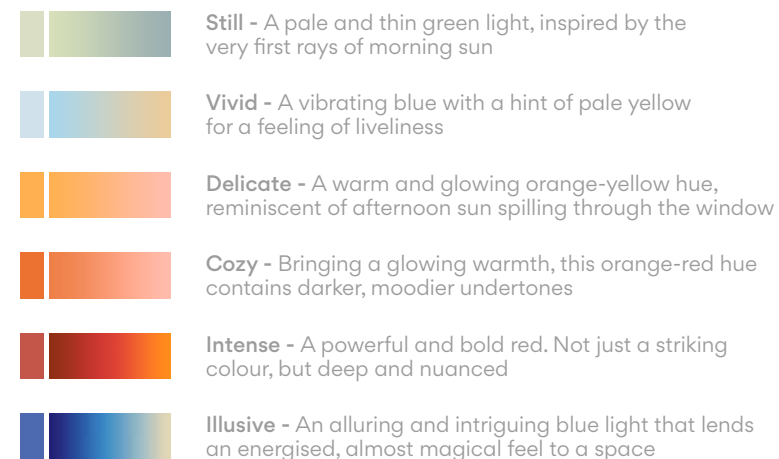

Contact Vibia Support Service at [vibia.com](http://vibia.com) for any kind of assistance or recommendation when designing an atmosphere of wellbeing, or if you require support with control system approach.

## Cozy colour mood

Bringing warmth and glow, this hue also contains darker, moodier undertones. A deep, burned red tone in the solid colour, while a colder grey-blue tone merges with the red in the gradient.

SURFACE

**2260**

Ø 54 cm



SURFACE

**2262**

Ø 92 cm



REMOTE

**2263**

Ø 92 cm



The Guise wall sconce consists of a glass disk emitting a perimeter glow from a hidden LED light source. When switched on it generates a halo of diffuse light like a solar eclipse; when switched off, the transparent glass and hidden LEDs seem to disappear, hence its enigmatic name.

● 18 Graphite (ADAPTA RF9913WX)

Diffuser: Borosilicate  
LED support: Aluminum

#### LED Colour Temperature

Ref. 2260, 2262

Static White  
3000 K

Ref. 2263  
Infinite Colour (RGB + TW)

CRI>90

#### Control

Ref. 2260, 2262

Analog: Optical sensor on the LED support

Ref. 2263

Smart: ProtoPixel\* (also with push buttons)



You can select any desired light -white, colour mood or gradient- and intensity manually from the analogic product interface.

\*ProtoPixel products are compatible with all other DALI-2 products via a designated gateway (please consult us)

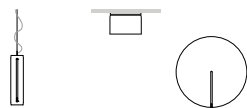



# Musa



Design by Note Design Studio.

A poetic expression of light, inspired by nature. Cradled by the soft curve of Musa's bowl-shaped diffuser, light is both contained and reflected in its silky veneer.





7415

Ø 26 x 10 cm

Musa recalls the organic form of an oyster and pearl. A small, dimmable diffuser nestles at its base, casting a soft glow that spreads across the larger sphere that contains and diffuses it.

- 23 Warm White (NCS S 0502-Y50R)
- 24 Beige M1 (NCS S 2005-Y50R)
- 36 Soft Pink (NCS S 1010-Y50R)

Finish customization  
(Available options: Vibia colour palette)

Diffuser: Blown glass  
Body: Aluminum

**LED Colour Temperature**  
2700 K  
CRI>90

**Control**  
Analog: 1-10V



# Funnel



A warm lighting presence with a distinctly sculptural form, Funnel is a study in materiality, light and space.





2012  
Ø 22 cm



2013  
Ø 35 cm

A fluid design defines this aluminum fixture, a streamlined, funnel-shaped base that flows into a protruding cap. The smooth, sculptural curves conceal a LED light source behind the tip, reflecting light back on the funnel form and creating a flood of indirect, ambient lighting. It can be displayed individually or in a row for greater impact.

- 10 White ( NCS S 0300-N)
- 36 Soft pink (NCS S 1010-Y50R)
- 47 Green L1 (NCS S 4005-G80Y)
- 51 Gold leaf (Gold)

Shade: Aluminum  
Reflector: Aluminum  
Support: Steel

**LED Colour Temperature**  
2700 K; 3000 K; 3500 K  
CRI>80; CRI>90

**Control**  
Analog: On/ Off; Push; 1-10V  
Digital: DALI-2

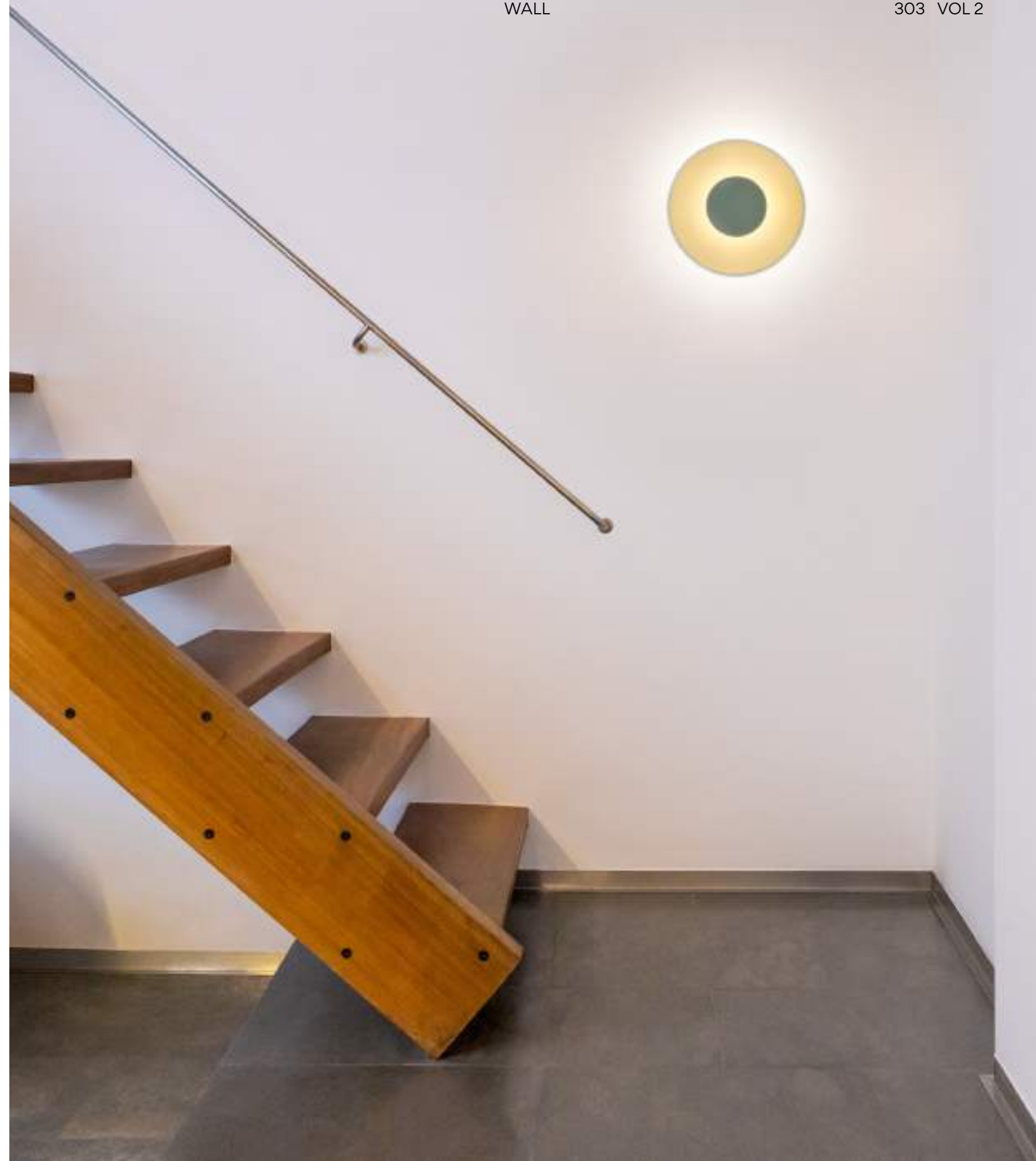
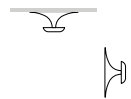
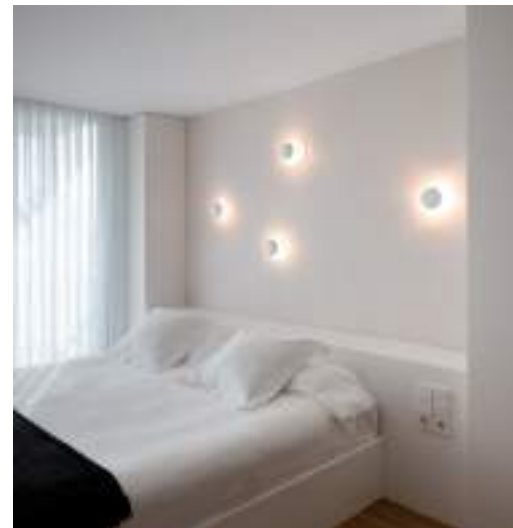

# Suite

Design by Jordi Vilardell & Meritxell Vidal.

The Suite wall light doubles up as a convenient storage facility. Depending on the desired effect, the user can choose from a range of different models: a simple shelf, a shelf with a reading lamp, a shelf featuring a luminous object, or an ambient wall sconce. The shelves incorporate an invisible LED tucked underneath, offering an ambient bedside glow.







**6046**  
32 x 29 x 16 cm



**6041**  
32 x 14 x 16 cm



**6040**  
32 x 14 x 16 cm



**6045**  
32 x 29 x 16 cm

- 14 Chocolate (RAL 8019)
- 23 Warm White (NCS S 0502-Y50R)

Finish customization  
(Available options: Vibia colour palette)

Diffuser: PC- Polycarbonate / Blown-glass  
Shelf: Aluminum  
Lid: Steel

**LED Colour Temperature**  
2700 K; 3500 K  
CRI>90

**Control**  
Analog: On/ Off

**6050**

12 x 12 x 10 cm

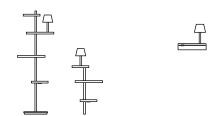

# I.Cono



Design by Lievore, Altherr, Molina.

Distinguished by its signature visor-shaped shade, I.Cono presents a poised, Scandinavian presence. The visual purity of its angular shade is matched by a sleek base and complemented by a range of elegant finishes.

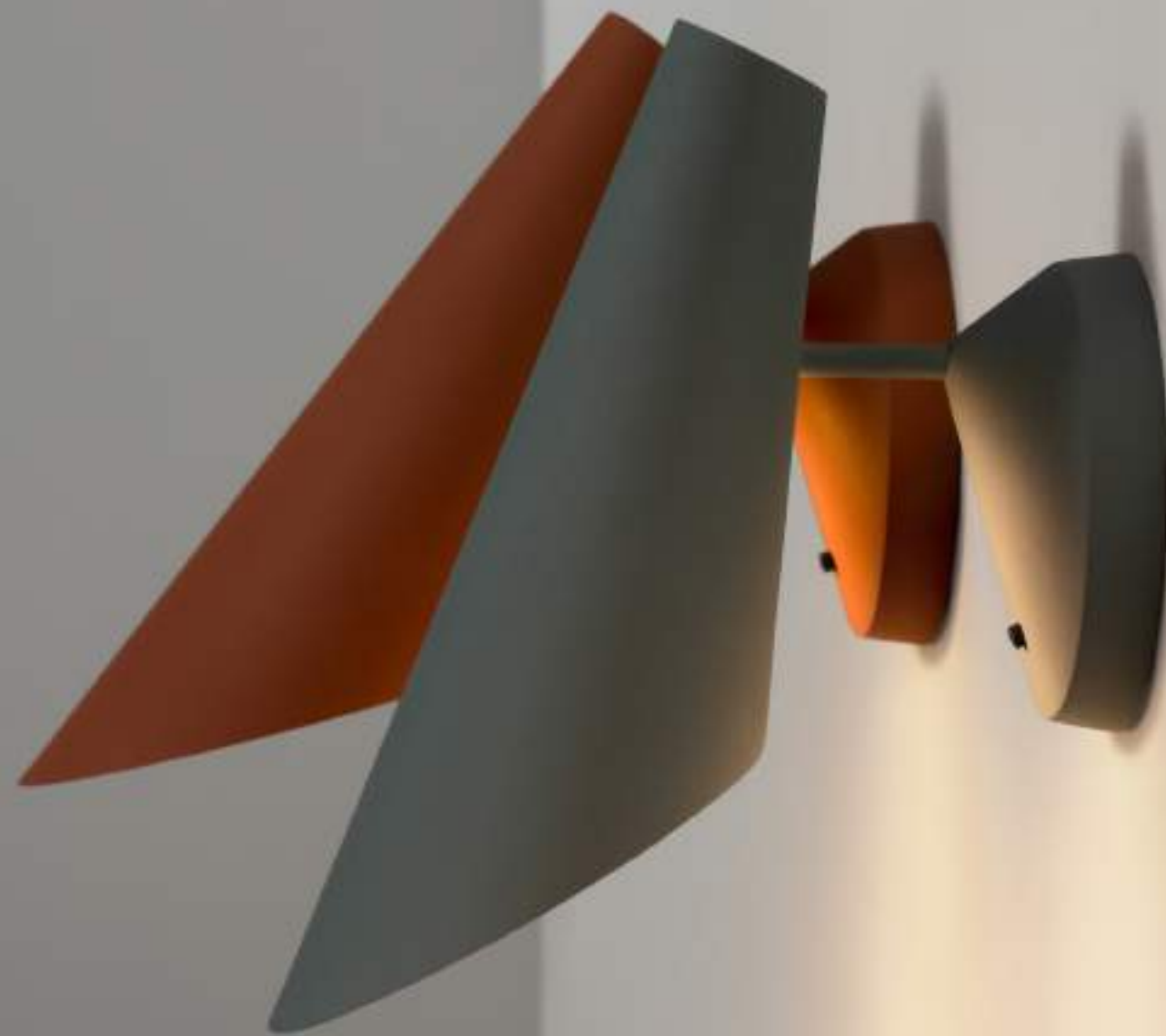



- 10 White (NCS S 0300-N)
- 21 Grey D1 (NCS S 7000-N)
- 25 Beige D1 (NCS S 4005-Y50R)
- 37 Terra Red (NCS S 4040-Y70R)
- 42 Blue M1 (NCS S 5010-B10G)

Shade: ABS + PC- Polycarbonate  
 Tube: Steel  
 Base: Aluminium

**LED Colour Temperature**

2700 K  
 CRI>90

**Control**

Ref. 0720  
 Analog: On/ Off  
 Ref. 0721  
 Analog: On/ Off; Push (Remote)  
 Digital: DALI-2 (Remote)  
 Smart: Casambi (Remote)



On/ Off switch on the base.

**0720**

15 x 17 x 26 cm



**0721**

15 x 17 x 26 cm

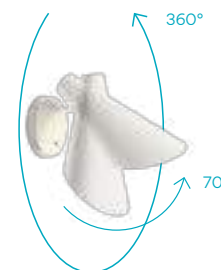

# Origami

Design by Ramón Esteve.

Inspired by the Japanese art of paper folding, Origami provides gentle ambient light illumination while doubling up as a striking installation. Light radiates out from a series of distinctive geometric structures, creating a dialogue of light and shadow across the wall.



- 10 White (NCS S 0300-N)
- 29 Brown D1 (NCS S 8005-Y50R)
- 38 Terra Dark (NCS S 5040-Y70R)
- 53 Green M1 (NCS S 6005-G80Y)

Shade: ABS  
 Diffuser: PC- Polycarbonate  
 Lid: PC- Polycarbonate  
 Arm: PC- Polycarbonate

**LED Colour Temperature**  
 2700 K; 3500 K  
 CRI>90

**Control**  
 Analog: TRIAC

A maximum of 30 modules can be connected to a single connection point.



**4506**  
 70 x 91 cm



**4500**  
 30 x 30 cm



**4501**  
 30 x 30 cm



**4504**  
 53 x 63 cm

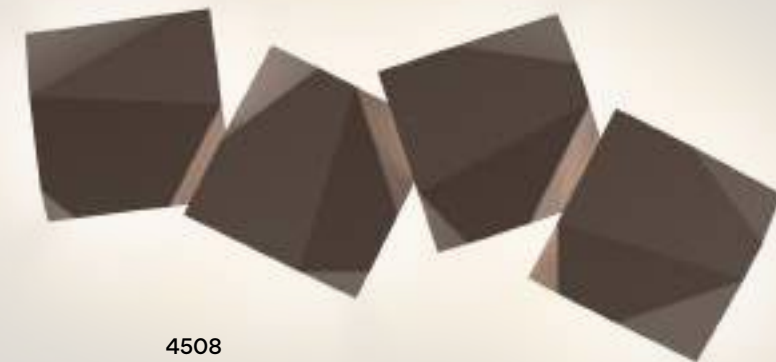

**4508**  
 94 x 107 cm

# Alpha

Design by Ramos & Bassols.

A wall lamp with basic lines and advanced lighting performance, its diffuser emits a warm, comfortable light.





**7940**  
12 x 12 cm



**7942**  
12 x 12 cm

- 18 Graphite & Black (RAL 7016 & RAL 9005)
- 93 White (RAL 9016)

Diffuser: PC- Polycarbonate  
Lid: Zinc Alloy  
Body: Aluminum  
Lid: Aluminum

**LED Colour Temperature**  
2700 K; 3500 K  
CRI>90

**Control**  
Analog: On/ Off

Ref. 7940  
On/off switch on the front cover  
Ref. 7942  
Without switch



# Puck



Design by Jordi Vilardell.

Glowing like a full moon, Puck's simple, spherical forms can be superimposed on top of one another, lending the whole an organic sensibility.







**5410**  
24,4 x 6,6 cm



**5412**  
27,2 x 7,7 cm



**5425 5427**  
31,8 x 24,2 cm

● 03 White (RAL 9016)

Canopy: Aluminum  
Diffuser: Blown-glass

**LED Colour Temperature**

2700 K; 3500 K  
CRI>90

**Control**

Analog: On/ Off

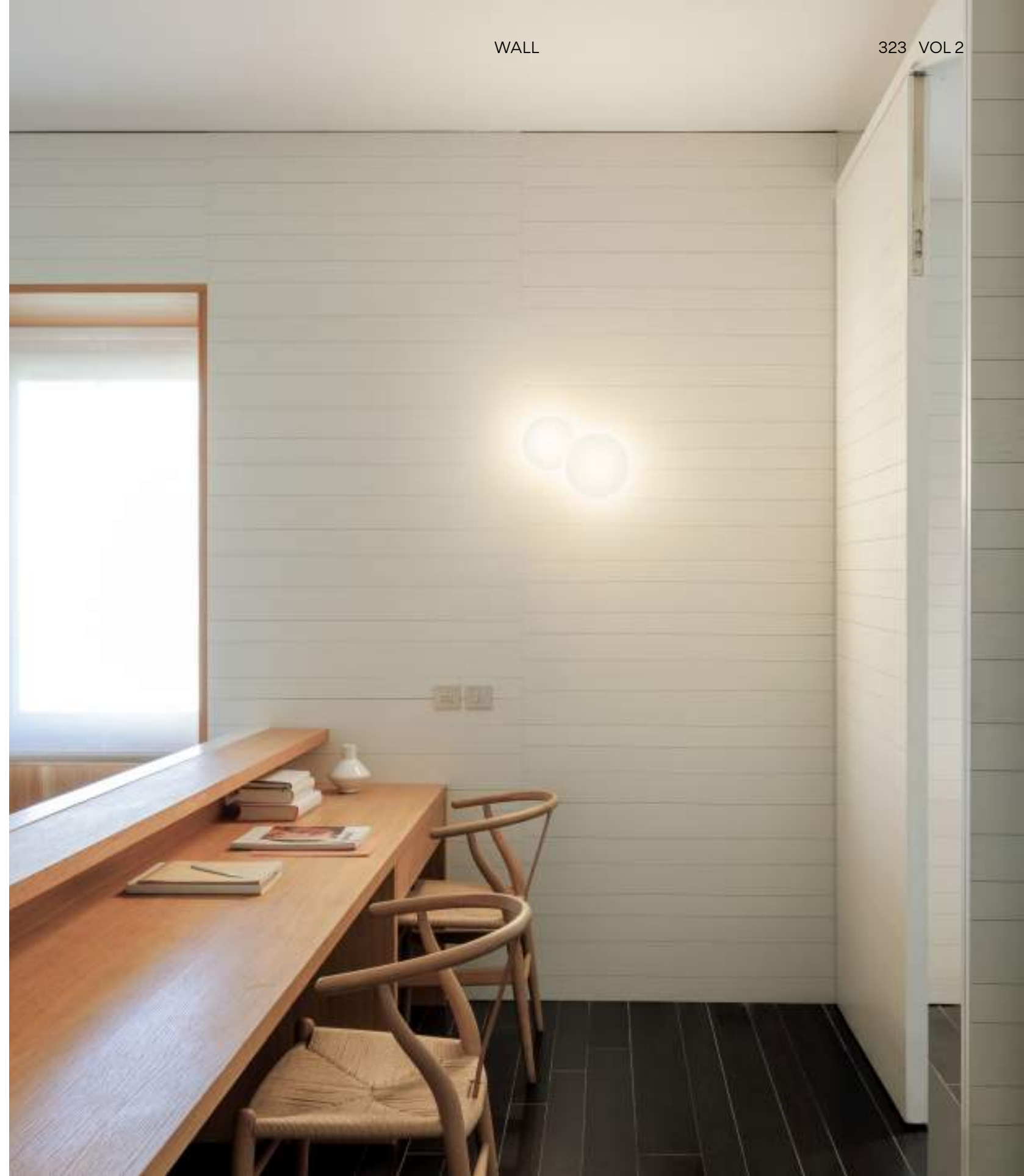
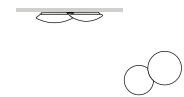
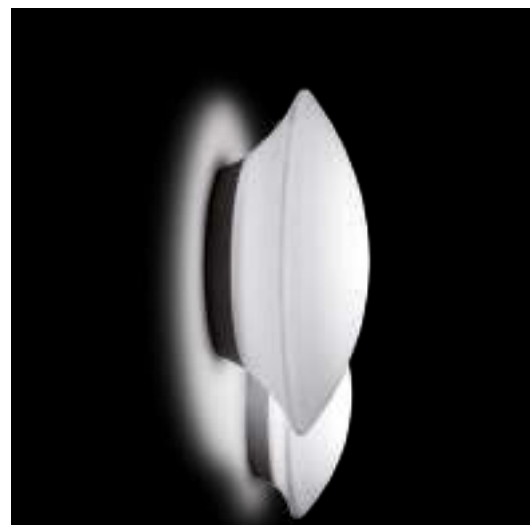

# Puck Wall Art



Design by Jordi Vilardell.

Puck Wall Art combines two circular wall lights of different sizes and colours, superimposed on top of one another, and combining to create a set of highly dynamic, sculptural compositions. The collection provides ambient indirect light and only requires a single electrical connection.



-  15 Grey L2 (NCS S 2500-N)
-  21 Black Grey (NCS S 7000-N)
-  28 Brown M1 (NCS S 4020-Y60R)
-  72 Black Grey & Grey L2 (NCS S 7000-N, NCS S 2500-N)
-  73 Brown M1 & Black Grey (NCS S 4020-Y60R, NCS S 7000-N)
-  76 Grey felt L1
-  77 Grey felt D1
-  71 Grey felt L1 & Grey felt D1

Diffuser: PC- Polycarbonate  
 Shade: ABS  
 Wall support: Aluminum

**LED Colour Temperature**

2700 K; 3500 K  
 CRI>90

**Control**

Analog: Push; TRIAC; 1-10V  
 Digital: DALI-2  
 Smart: Casambi

A maximum of 8 modules can be connected to a single connection point



**5470**  
 Ø 30 cm



**5471**  
 Ø 40 cm



**5472**  
 Ø 45 cm



**5474**  
 Ø 46 cm



**5476**  
 Ø 60 cm



**5480**  
 58 x 58 x 6 cm



**5481**  
 69 x 69 x 9 cm



**5485**  
 68 x 68 x 9 cm



**5487**  
 87 x 87 x 9 cm



**5486**  
 87 x 87 x 11 cm



**5491**  
 103 x 84 x 11 cm



Puck Wall Art is comprised of different disks to create a warm, visually sharp and mathematically creative effect. There are four sizes of disks, allowing the designer to play with varied combinations of indirect light. The resulting design comprises a set of highly dynamic, sculptural compositions.

# North



Design by Arik Levy.

The North collection consists of a conical aluminum shade hanging from an adjustable carbon fibre rod. The rod and shade are disconnected from one another via a slim cable, directing the LED-powered light where needed in a dynamic system of adjustable parts.



**5630**

150 x 195 cm

For the North wall light, a slender rod rises from a base attached to the wall. The light source and shade are separated from the base, suspended delicately in mid-air from the tip of the rod. Available in four lacquered matte tones, it can be adapted to any style for both private and public use. North provides flat uniform light of a local yet flexible character.

- 10 White (NCS S 0300-N)
- 11 Black (NCS S 8500-N)
- 24 Beige M1 (NCS S 2005-Y50R)
- 42 Blue M1 (NCS S 5010-B10G)

Rods: Carbon fiber  
 Shade: Aluminum  
 Diffuser: PMMA  
 Wall Plate: Steel

**LED Colour Temperature**  
 2700 K; 3000K  
 CRI>90  
 3500 K  
 CRI>80

**Control**  
 Analog: Push

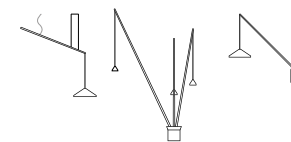

Pg 264/412 VOL 1 Pg 330 VOL 2



North combines pendant and wall application to provide elegant and adjustable solutions. Choose from different shade sizes for more focused or diffused illumination.

# Halo



Design by Martín Azúa.

Halo's graphic simplicity lends it an ethereal quality. The fixture seems to float in mid-air, powered by invisible LEDs hidden within its opalized, linear diffuser.





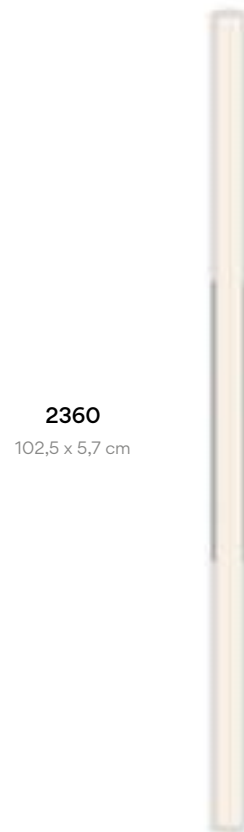

**2360**  
102,5 x 5,7 cm

When composed as a collection, Halo comes alive with new compositional value. Rotation around a central axis allows the light sticks to be positioned as desired, creating a luminous mural that bathes the surrounding wall in a diffuse light.

- 11 Black (NCS S 8500-N)
- 13 Off-White (NCS S 1000-N)

Diffuser: PMMA  
LED support: Aluminum

**LED Colour Temperature**

2700 K  
CRI>90  
3000 K  
CRI>80

**Control**

Analog: 1-10V  
Digital: DALI-2  
Smart: Casambi (Remote)

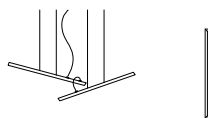

Pg 218 VOL 1 Pg 336 VOL 2



# Sticks



Design by Arik Levy.

A pure solution for a minimalist interior, Sticks features luminaires of various lengths and incorporates a range of electrical connection options for seamless integration with the surrounding architecture.







Horizontal version with a UGR index <math>< 19</math> available



Linear flat diffuser



● 11 Black (S 8500-N)  
Stick: Aluminum  
Diffuser: PC- Polycarbonate

**LED Colour Temperature**  
2700K; 3000K; 3500K  
CRI>90

**Control**  
Analog: Push, 1-10V  
Digital: DALI-2  
Smart: Casambi

**Electrical connection options**

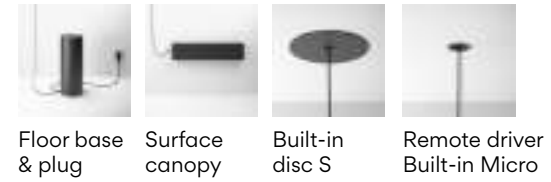

**Connecting space application**

Sticks offers a creative lighting toolkit for integrating light elements in an interior space, connecting the different architectural planes.

**Connectable**

The Sticks collection has three sizes: 1.5 m, 2 m, or 3 m, and they can be connected one to each other to a total maximum length of 6.5 meters per electrical connection.

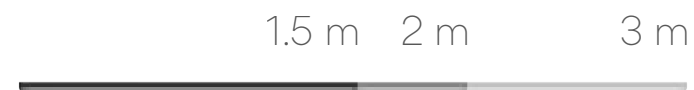

Sticks are connected one to each other with a 15 cm length cord.

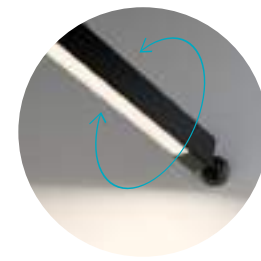

Each stick rotates on its own axis, allowing light to be directed precisely where needed.

**Wall-Wall**

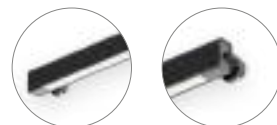

**Wall-Wall (corner) / Wall-Ceiling**

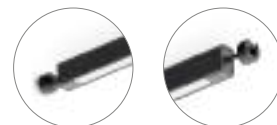

**Wall-Pendants**

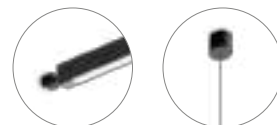

**Floor-Wall**

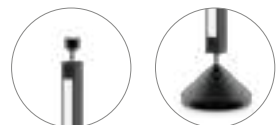

WALL



# Offset



Up&Down  
Surface Grazer

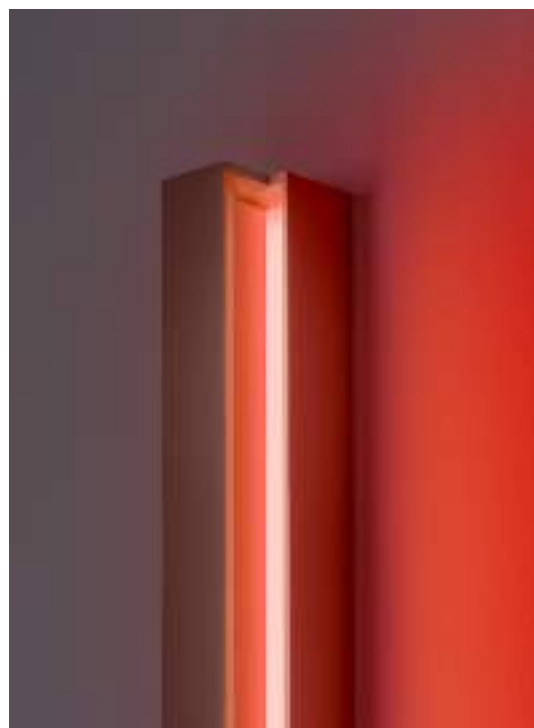

Colour  
Mood Grazer

Design by Xuclà.

Offset combines soft, indirect light with an industrial, geometric silhouette. Offering a range of linear or angular luminaires and available in a range of different sizes, the system guarantees the versatility to adapt to any space.

- 11 Black (NCS S 8500-N)
- 24 Beige M1 (NCS S 2005-Y50R)
- 23 Warm White (NCS S 0502-Y50R)



Up&Down



- 11 Black (NCS S 8500-N)
- 23 Warm White (NCS S 0502-Y50R)
- 24 Beige M1 (NCS S 2005-Y50R)

Ref. 1770, 1772 and 1774  
 Body: Aluminum  
 Lens: PMMA

Ref. 1760, 1762, 1765 and 1767  
 Body: Aluminum  
 Diffuser: PC - Polycarbonate

**LED Colour Temperature**  
 Ref. 1770, 1772 and 1774  
 Static White  
 2700 K; 3000 K; 3500 K  
 Ref. 1760, 1762, 1765 and 1767  
 Infinite Colour (TW + RGB)  
 CRI >90

**Control**  
 Ref. 1770  
 Analog: On / Off; Push (Remote)  
 Digital: DALI-2 (Remote)  
 Smart: Casambi (Remote)  
 Ref. 1772 and 1774  
 Analog: Push  
 Digital: DALI-2  
 Smart: Casambi  
 Ref. 1760, 1762, 1765 and 1767  
 Smart: ProtoPixel\*  
 \*ProtoPixel products are compatible with all other DALI-2 products via a designated gateway (please consult us)

Up&Down Surface Grazer

|              |                |                |
|--------------|----------------|----------------|
| <b>1770</b>  | <b>1772</b>    | <b>1774</b>    |
| 7 x 7 x 4 cm | 7 x 100 x 4 cm | 7 x 160 x 4 cm |

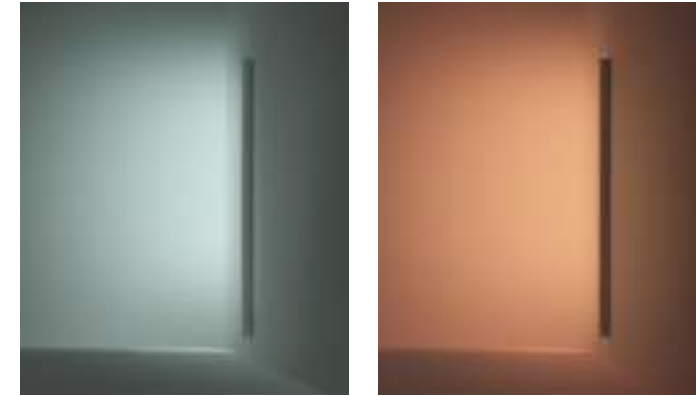

Colour Mood Grazer

|                |             |                |             |
|----------------|-------------|----------------|-------------|
| Left           | Right       | Left           | Right       |
| <b>1762</b>    | <b>1760</b> | <b>1767</b>    | <b>1765</b> |
| 7 x 125 x 5 cm |             | 7 x 225 x 5 cm |             |





## A source of emotion

Colour is a source of emotion it can instantly set a mood, convey a feeling or generate a sense of wellbeing

Vibia's approach to coloured light invites the use of colour and gradients to create and experience different atmospheres, making them as natural and subtle as possible. Natural light is never mono-tonal. Gradients come in infinite colours.

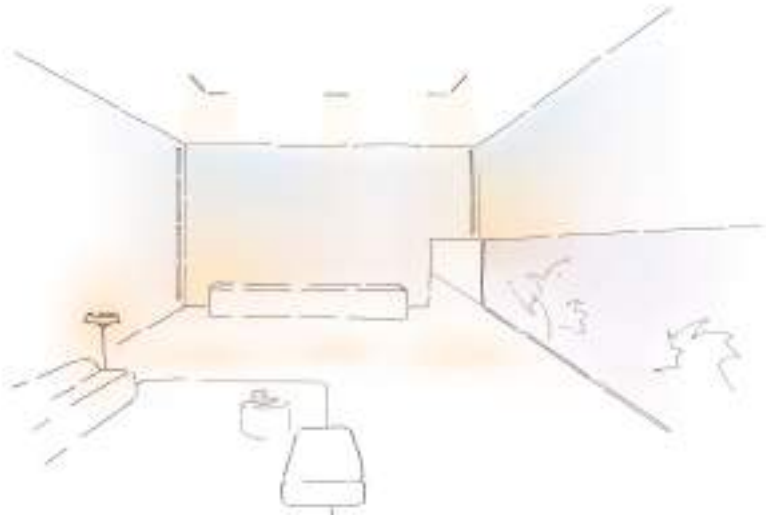

## Vibia Chromatica colours of light

### Static White

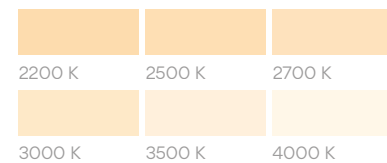

You can select any desired light -white, colour mood or gradient- and intensity manually from the analogic product interface. You can also integrate your selection into the control system for specific scene design and activate it using the Vibia App

### Colour Moods

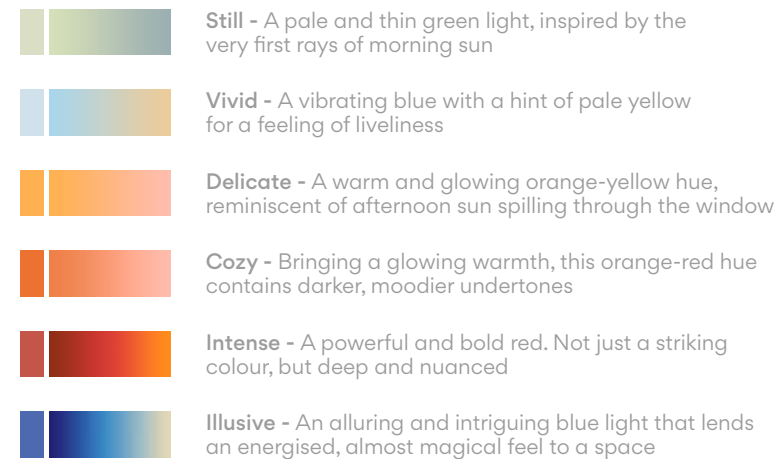

Contact Vibia Support Service at [vibia.com](http://vibia.com) for any kind of assistance or recommendation when designing an atmosphere of wellbeing, or if you require support with control system approach.

## Vivid colour mood

Full of vitality, this is a brisk and honest light. The solid colour is a vibrating blue with a hint of warmth, while the pale yellow in the gradient gives a feeling of liveliness — perfect for boosting energy and focus.

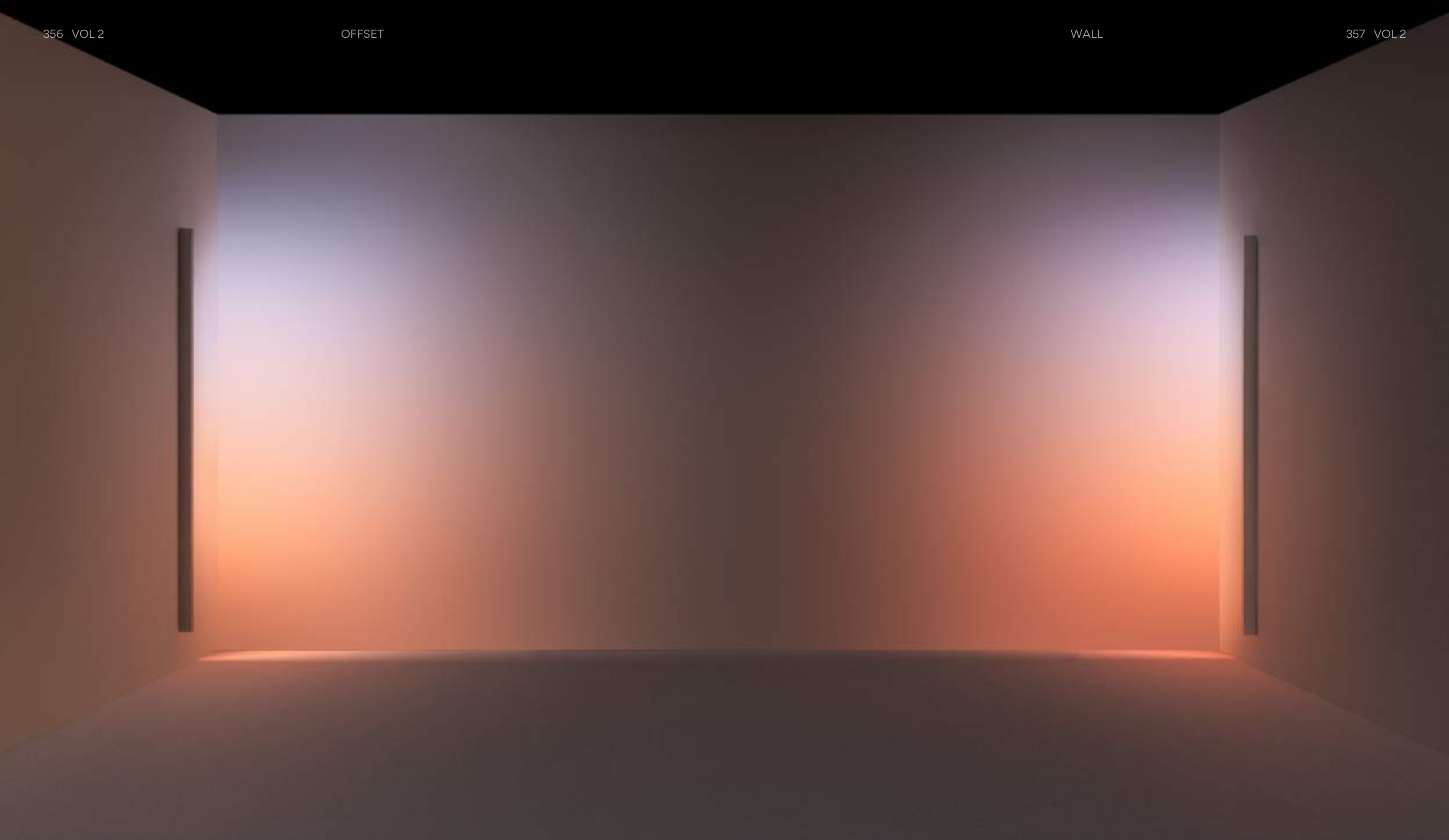

Outdoor

# Outdoor

Bamboo  
414

Empty  
408

Break  
430

June  
446

Break Plus  
435

Meridiano  
450

Brisa  
402

Origami  
388

Class  
456

Out  
378

Dots  
Glass  
372

Palo Alto  
394

Dots  
Outdoor  
360

Wind  
422

# Dots Outdoor



Design by Martín Azúa.

Diminutive, compact and easily installed, Dots Outdoor is the perfect solution for subtle outdoor illumination. Designed to nestle discreetly into the undergrowth of a garden or patio, Dots shines at night with a diffuse or focused glow from an invisible source.







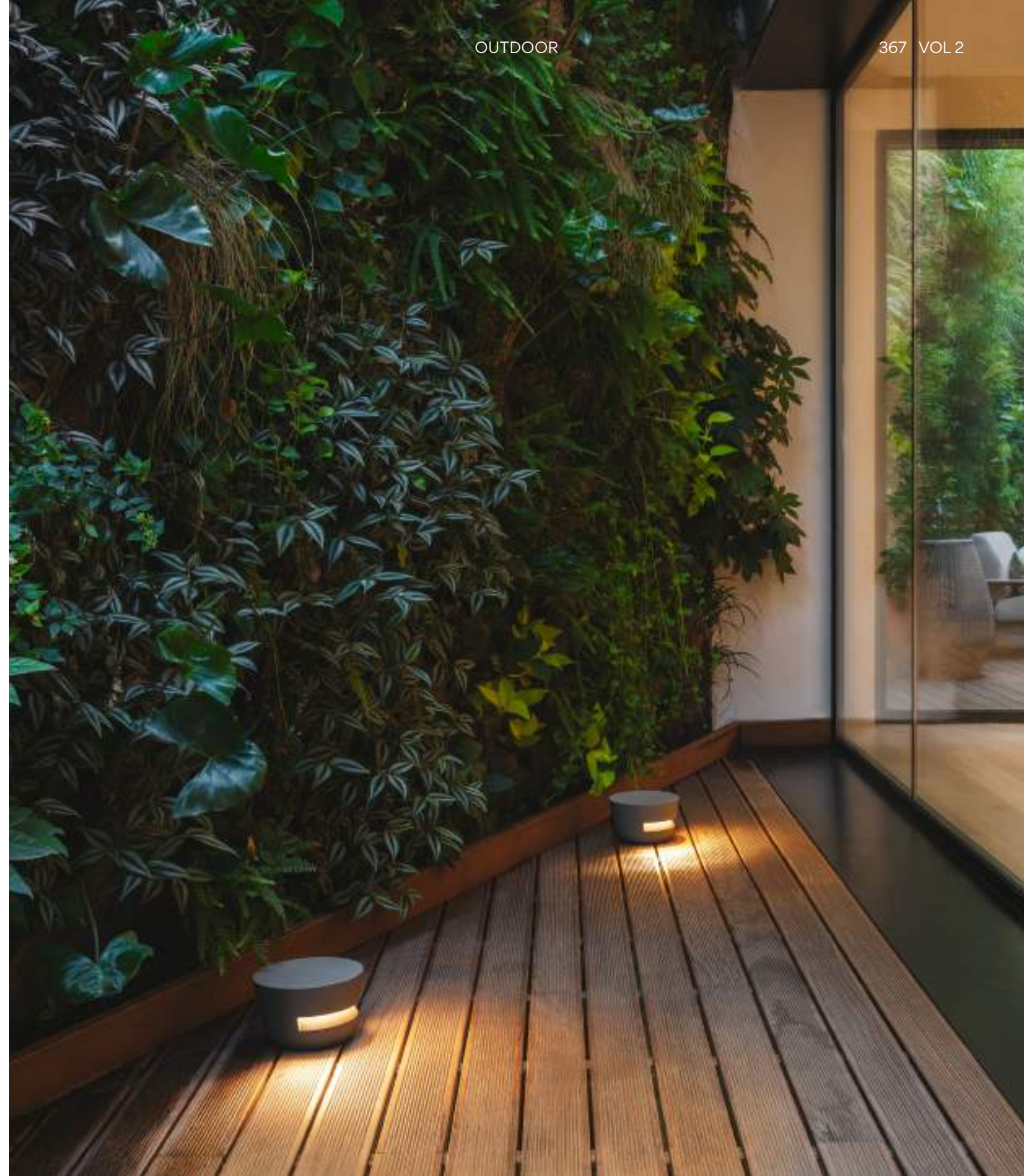





To connect interior and exterior living spaces, designers are increasingly bringing indoor qualities to the outdoor environment. Whether you want to enhance the existing scenery, integrate an outdoor seating area, or simply add a layer of security, Dots offers an extensive range of durable and weather resistant lighting solutions.





4684  
Ø 20 cm



4688  
Ø 20 cm

- 22 Graphite Black (NCS S 8000-N)
- 25 Beige D1 (NCS S 4005-Y50R)
- 53 Green M1 (NCS S 6005-G80Y)

Body: Aluminum  
Diffuser: PC- Polycarbonate

**LED Colour Temperature**

Ref. 4684, 4688  
2700 K; 3500 K

Ref. 4695, 4697, 4700, 4702  
2700 K

CRI>90

**Control**

Analog: On/ Off; 1-10V  
Digital: DALI-2 (Remote)  
Smart: Casambi (Remote)

IP65 | IP66 | Bi-volt



4695  
Ø 20 x 12 cm



4697  
Ø 15 x 9 cm



4700  
Ø 20 x 12 cm



4702  
Ø 15 x 9 cm



# Dots Glass



Design by Martín Azúa.

Sheathed in layers of transparent optical glass, the LED source within the Dots Glass diffuser generates a warm, 360-degree glow with a pulsating ambient effect.

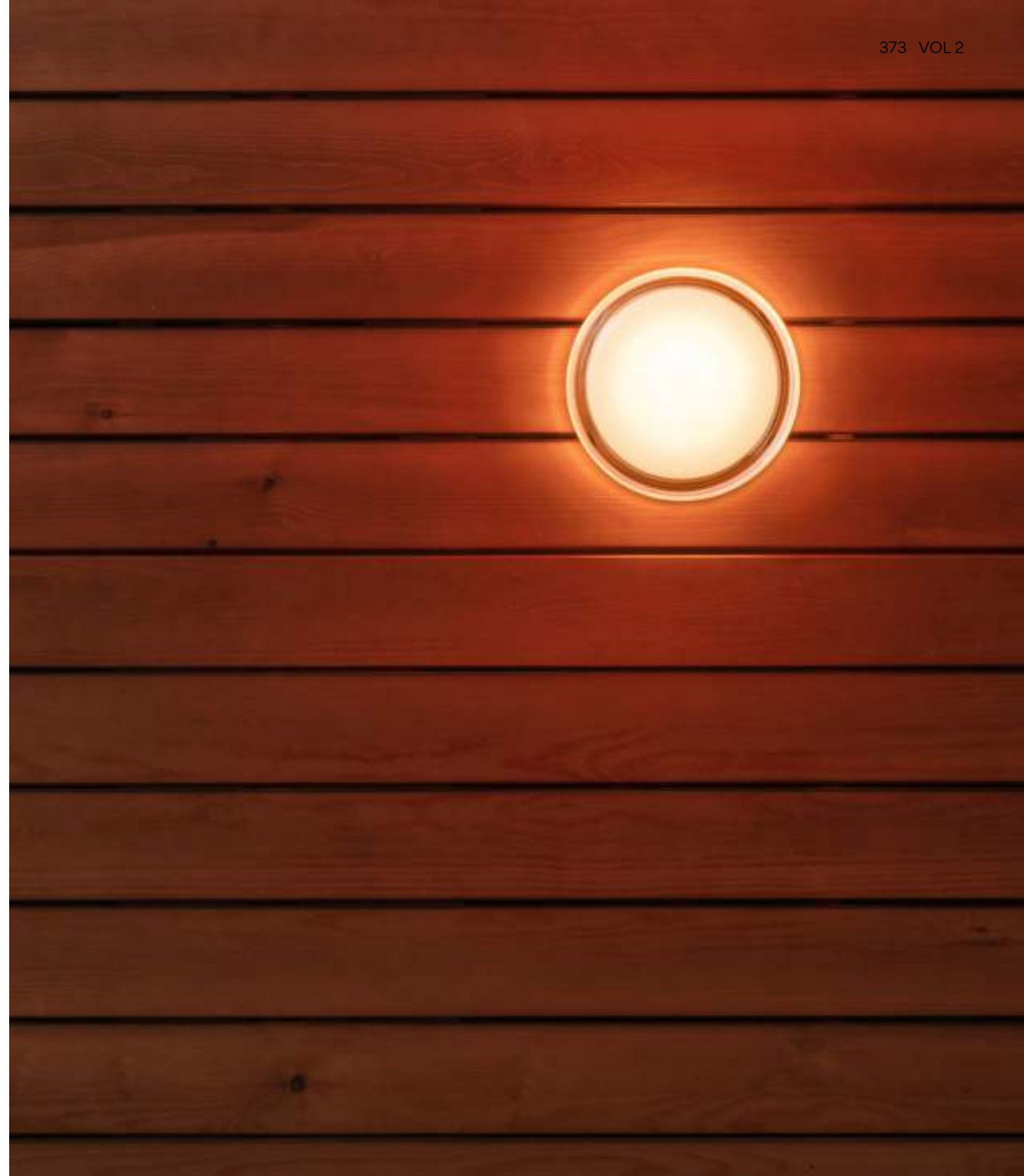



Ideal for transitional or walkway lighting, Dots Glass projects a subtle, lunar glow, highlighting the texture of its surrounding environment. Planted as a single star in the darkness, or combined with other elements of the collection, this sleek addition lends a delicate aesthetic.



4680  
Ø 20 cm

● 10 White (NCS S 0300-N)

Body: Aluminum  
Diffuser: Optical Glass

**LED Colour Temperature**  
2700 K; 3500 K  
CRI>90

**Control**  
Analog: On/ Off; 1-10V  
Digital: DALI-2  
Smart: Casambi (Remote)

IP66



# Out

Design by Víctor Carrasco.

Out is a romantic response to the global transition towards outdoor living. Available in a range of soothing colours, this innovative floor fixture projects a diffuse downlight that's ideal for illuminating a table or communal area.



47 Green L1



● 22 Graphite Black

Out brings the intimacy of indoor lighting outdoors.



● 25 Beige D1



Indoor & outdoor

Linking interior and exterior spaces has a significant impact on our sense of wellbeing. As we enter an era where outdoor space is becoming increasingly essential, design professionals are turning their attention towards breaking down traditional architectural barriers.







● 23 Warm White

● 36 Soft Pink

Out brings a poetic aesthetic, its slender stem extending vertically into the air before bending over in a broad arch. Forming islands of light in the darkness, its balanced structure and large scale allow people to pass underneath without complicating the space.

● 47 Green L1





- 22 Graphite Black (NCS S 8000-N)
- 23 Warm White (NCS S 0502-Y50R)
- 25 Beige D1 (NCS S 4005-Y50R)
- 36 Soft Pink (NCS S 1010-Y50R)
- 37 Terra Red (NCS S 4040-Y70R)
- 47 Green L1 (NCS S 4005-G80Y)

Tube: Stainless Steel  
 Shade: Aluminium  
 Diffuser: PE- Polyethylene

**LED Colour Temperature**  
 2700 K  
 CRI>90

**Control**  
 Ref. 4270  
 Analog: Push  
 Smart: Casambi; ProtoPixel\*  
 \*ProtoPixel products are compatible with all other DALI-2 products via a designated gateway (please consult us)  
 Ref. 4275  
 Digital: DALI-2  
 Smart: Casambi (Remote)

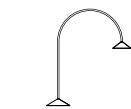

Pg 468 VOL 1  
 Pg 378 VOL 2

4270. Cable with switch



**4270 Not Fixed** IP44  
 211 x 242 cm



**4275 Bolt-down "hard wired"** IP65  
 211 x 242 cm

# Origami

Design by Ramón Esteve.

Inspired by the Japanese art of paper folding, Origami offers gentle exterior illumination while doubling up as a striking installation. Designed to climb like ivy, light radiates out from a series of distinctive geometric structures, creating a play of light and shadow across a wall.







4506

70 x 91 cm



4500

30 x 30 cm



4501

30 x 30 cm



4504

53 x 63 cm



4508

94 x 107 cm

Origami invites you to get creative. A single point of connection between pieces allows professionals to make as many patterns or configurations as desired, combining functionality with infinite versatility.

- 10 White (NCS S 0300-N)
- 29 Brown D1 (NCS S 8005-Y50R)
- 38 Terra Dark (NCS S 5040-Y70R)
- 53 Green M1 (NCS S 6005-G80Y)

Shade: ABS  
 Diffuser: PC- Polycarbonate  
 Lid: PC- Polycarbonate  
 Arm: PC- Polycarbonate

**LED Colour Temperature**  
 2700 K; 3500 K  
 CRI>90

**Control**  
 Analog: TRIAC

IP65

A maximum of 30 modules can be connected to a single connection point

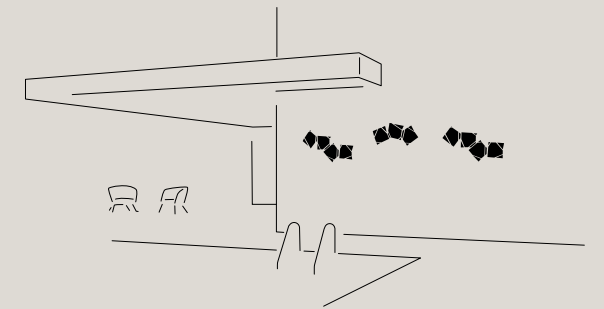
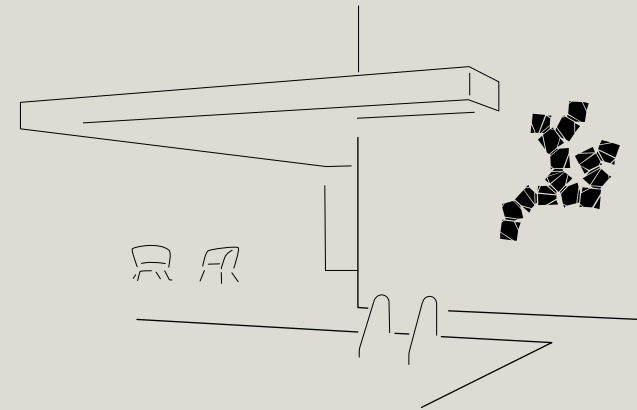

# Palo Alto

Design by Xuclà.

Palo Alto is defined by a linear, angular silhouette. Industrial in style yet natural in form, it recalls a tree whose steel “branches” are embedded with LEDs, illuminating the surrounding landscape with a diffuse downlight.



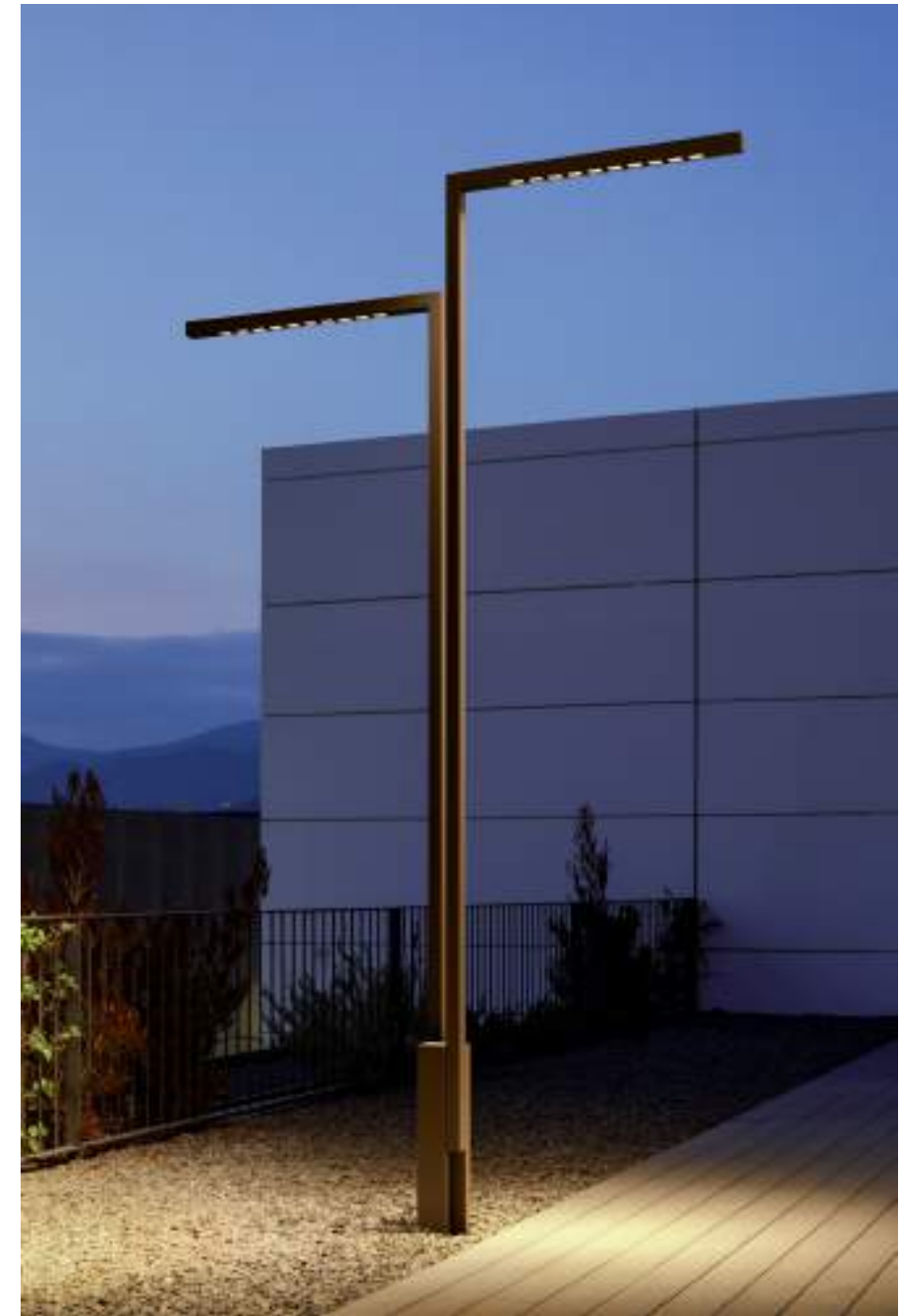

Thanks to its heights, shapes and angles, Palo Alto integrates seamlessly into any outdoor environment



It is offered in various minimalist shapes and can be displayed individually or in a group to resemble a stand of trees. The upper reaches of the sturdy steel fixture are fitted with slim swaths of LEDs directed downwards to create a diffused, ambient glow.



Ground surface mounted.





4510  
35 x 90 cm



4516  
85 x 280 cm



4539  
85 x 310 cm



4540  
136 x 310 x 161 cm

- 22 Graphite Black (NCS S 8000-N)
- 29 Brown D1 (NCS S 8005-Y50R)

Body: Steel  
Cover: Steel

**LED Colour Temperature**  
2700 K; 3500 K  
CRI>90

**Control**  
Analog: On/ Off

IP65



# Brisa

Design by Lievore, Altherr, Molina.

Inspired by the forest blue bellflower, Brisa is the essence of flawless landscape integration. Its stylised silhouette and natural inspiration bring a subtle charm to any exterior.



Brisa adds a nature-inspired accent to any space. True to its name, which means breeze in Spanish, Brisa's silhouette is delicate and graceful. Its long, slender stem is topped with a hanging, conical shade that beautifully captures the bloom's languid look. The simple architecture and distinctive bowed head lend it a quiet presence that accents an outdoor space rather than overpowering it. Offered with 1, 3, or 5 arms, it resembles a solitary plant or grouping of flowers in a natural setting. The LED-powered light source casts a warm, bright beam, making it ideal for focused illumination. The collection is available in a surface mounted or built-in style.

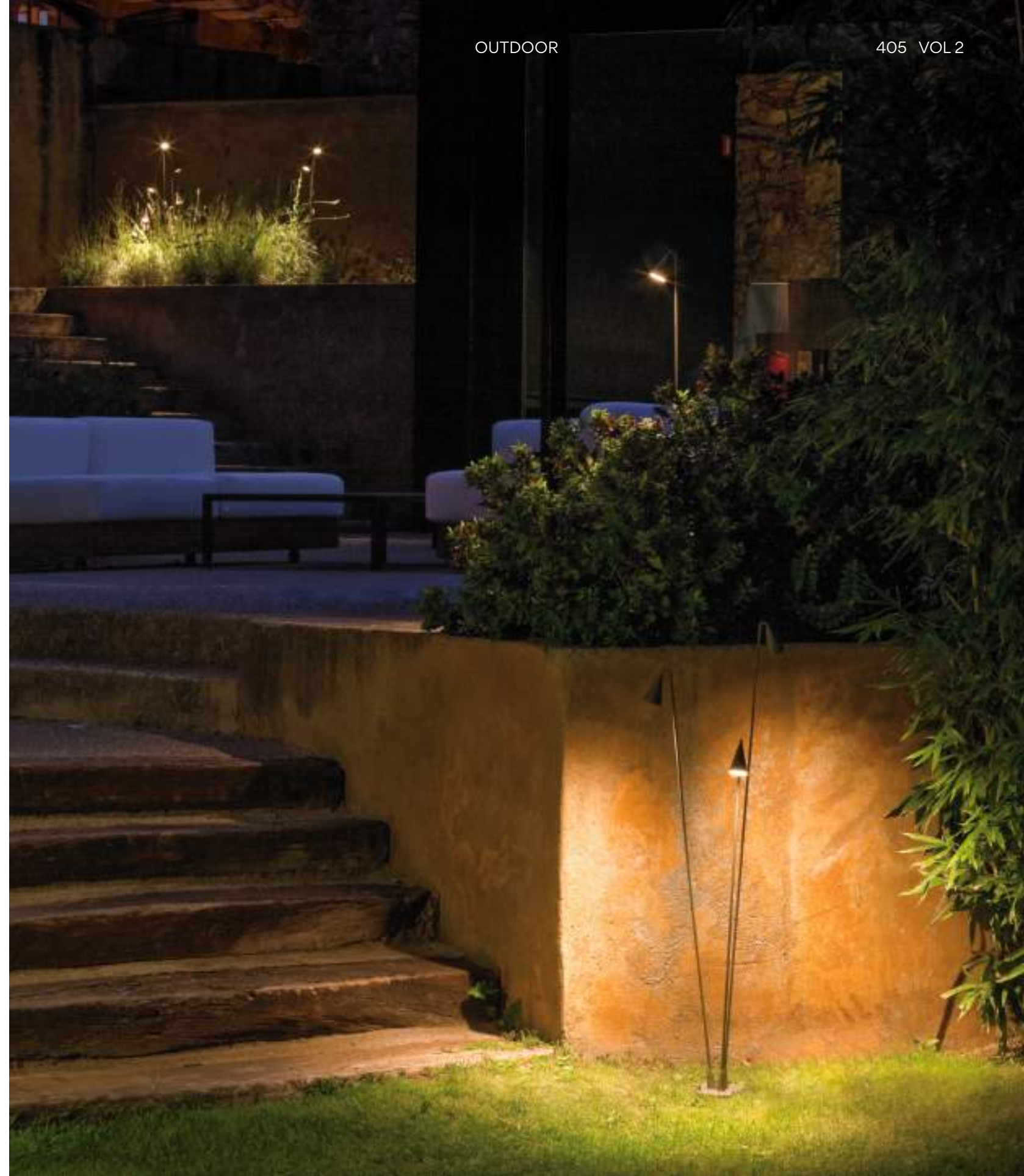



**4625**  
10 x 103 cm



**4630**  
10 x 100 cm



**4635**  
22 x 99,5 x 23 cm



**4640**  
30 x 100 x 27,5 cm

- 07 Khaki (RAL 7039)
- 54 Oxide (RAL 8014)

Shade and Base: Aluminum.  
Disc: Stainless steel.  
Vertical tube: Steel.

**LED Colour Temperature**  
2700 K; 3500 K  
CRI>90

**Control**  
Analog: On/ Off

IP64 IP65



# Empty

Design by Xuclà.

Empty, lends itself to Vibia's 'furniture meets light' concept. Incorporating a table, stool and light fixture into a single three-dimensional entity, each geometric structure glows with subtle, indirect light from an invisible source.



**4125**  
45 x 45 cm

**4130**  
45 x 70 cm



**4135**  
25 x 25 cm

**4136**  
25 x 55 cm

- 18 Polymer Concrete Grey (NCS S 2002-B50G)
- 22 Graphite Black (NCS S 8000-N)

Body: Polymer Concrete  
Diffuser: PMMA

**LED Colour Temperature**  
2700 K; CRI>80  
3500 K; CRI>90

**Control**  
Analog: On/ Off

IP66



Floor lamp and furnishing in one, Empty's crisp angles create a cantilevered perch that serves as a side table or stool, while making a sleek modernist statement. A LED light source tucked discreetly under the seat casts a warm glow that's ideal for walkways or general exterior illumination.



# Bamboo



Design by Antoni Arola & Enric Rodríguez.

Bamboo's lean, natural form perfectly lends itself to an outdoor setting. Studded with LEDs, it seamlessly integrates with the landscape while adding a wash of light to walkways and common spaces.









Bamboo was clearly inspired by its namesake. Characterised by a slender silhouette that blends in with the existing flora, the fixture can be 'planted' into decking or gravel, illuminating the adjacent wall with lively "spots" of light.

- 07 Khakhi (RAL 7006)
- 54 Oxide (RAL 8017)
- 58 Off-White (Pantone Warm Gray 2U)

Cane: PES+FG- Fiberglass  
 Diffuser: PMMA

**LED Colour Temperature**  
 2700 K; 3500 K  
 CRI>90

**Control**  
 Analog: On/ Off

IP66



**4820**  
 19 x 6 cm



**4812**  
 Ø 40 x 270 cm



**4811**  
 Ø 35 x 270 cm



**4810**  
 Ø 43 x 190 cm



**4805**  
 6 x 270 cm



**4804**  
 6 x 190 cm



**4801 4803**  
 6 x 90 cm



**4800 4802**  
 6 x 60 cm



Ref. 4800, 4801, 4820 surface mounted.

Ref. 4802, 4803, 4804, 4805, 4810, 4811 and 4812 built-in installation.



# Wind



Design by Jordi Vilardell.

A perfect marriage of technology and tradition. Wind's drum shade is made of fibreglass, an innovative webbed texture and pattern that elevates the visual contribution of this timeless silhouette.





Besides its large scale, the principle characteristic of the Wind collection is its materiality. The traditional drum shade is made from delicately woven fibreglass, producing a uniquely textured surface with a warm, ambient lighting effect.





**4072**  
Ø 60 cm



**4077**  
Ø 60 cm



**4078**  
Ø 120 cm

- 27 Sand (NCS S 1505-Y50R)
- 53 Green M1 (NCS S 6005-G80Y)
- 61 Ocre Red (NCS S 3050-Y60R)

Shade: FG- Fiberglass  
Base: FG- Fiberglass  
Diffuser: FG- Fiberglass  
Canopy Plate: Steel  
Lid: Steel

**LED Colour Temperature**

2700 K  
CRI>90

**Control**

Analog: On/ Off

Ref. 4057, 4062, 4067 **IP64**

Ref. 4072, 4077 **IP65**

Ref. 4078 **IP20**

Ref. 4057  
Shade: FG- Fiberglass  
Weight: Concrete  
Lid: Steel  
Diffuser: PMMA



**4057**  
Ø 60 x 191 cm



**4062**  
Ø 120 x 195 cm



**4067**  
Ø 60 x 166 cm

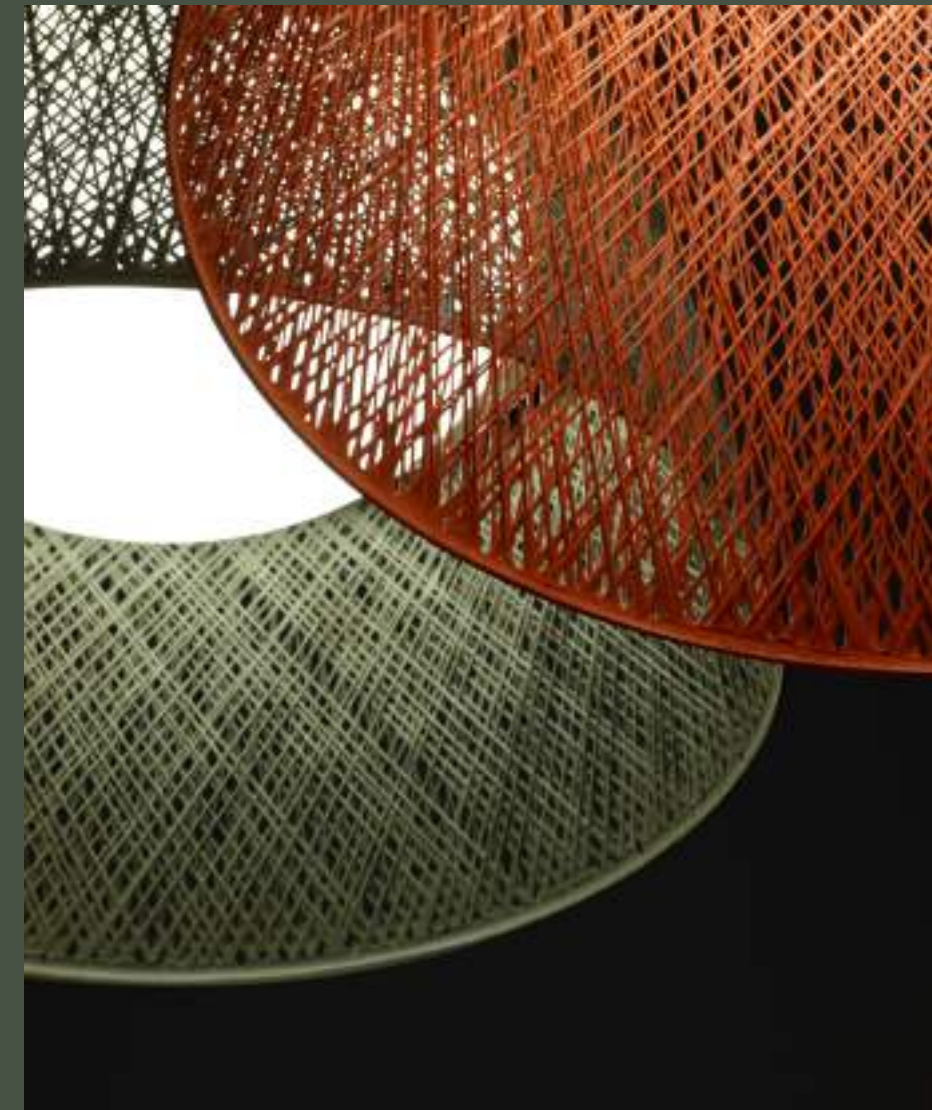
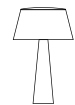

# Break



Design by Xuclà & Alemany.

Break is distinguished by its architectural attitude. A series of cubic volumes provide indirect downlight while doubling up as a dynamic sculptural presence.







**4101**  
25 x 81 cm



**4106**  
25 x 43 cm



**4108**  
48 x 38 cm

The Break collection consists of a bevelled cube with a recess from which light escapes, and a pair of blocks stacked on top of one another, the space between them allowing light to pass through. Dotted in pairs and groups of three, Break's graphite black lacquer and concrete finishes blend effortlessly with an industrial aesthetic.

- 80 Concrete (Natural finish)
- 22 Graphite Black (NCS S 8000-N)

Head: Concrete  
Base: Concrete  
Diffuser: PMMA  
Body: Steel

**LED Colour Temperature**  
2700 K  
CRI>80

**Control**  
Analog: On/ Off

IP66





# Break Plus

Design by Xuclà.

Designed to blend instinctively with the architecture in which it exists, Break Plus converts any wall into a three dimensional mural. Arranged individually or as a group, it consists of four geometric volumes that cast beams of diffuse light upwards, downwards -or in both directions- creating a dynamic dialogue between light and shadow.





Break Plus guarantees seamless adaptation to the surface upon which it is mounted. The collection's lacquered matte finish adds a natural, grainy texture that complements its clean, geometric expression.





Characterised by its stylized silhouette and available in four muted Chromatica colours, these playful units display an ethereal lighting effect on the wall.





Break Plus is evocative of a roof tile or brick, designed individually to connect as a whole. Integrating into the architecture of any space, the collection presents five geometric models that provide spatial depth and aesthetic plasticity to an otherwise flat surface. When grouped together, the collection creates a dynamic dialogue between light and shadow: light is reflected from the interior of each volume, drawing a single or double or beam across the wall, which merge to establish a lattice of oblique lines. Easily installed and with on/ off, Dali and Casambi control systems, its lacquered matte finish adds a hint of graininess that complements its geometric form.

A singular study in high performance technology, Break Plus is designed to withstand all weather conditions. Surface mounted and easily maintained, its unique form prevents water from stagnating, making it the ideal choice for both private residential properties as well as larger commercial projects.



**4112**  
12 x 14 cm

**4114**  
12 x 14 cm

**4116**  
21 x 34 cm

**4118**  
19 x 32 cm

- 22 Graphite Black (NCS S 8000-N)
- 25 Beige D1 (NCS S 4005-Y50R)
- 37 Terra Red (NCS S 4040-Y70R)
- 95 Primer (NCS S 1000-N)

Body: Aluminum  
Diffuser: PC- Polycarbonate

**LED Colour Temperature**  
2700 K; 3500 K  
CRI>90

**Control**  
Analog: On/ Off  
Digital: DALI-2 (Remote)  
Smart: Casambi (Remote)

IP65

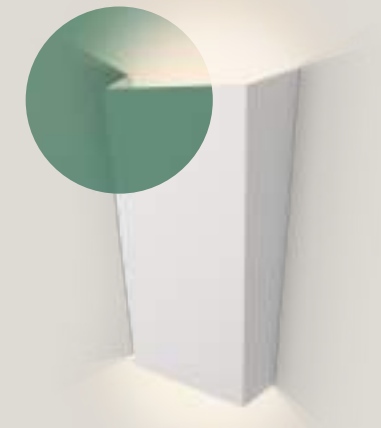

Primer finish: customisable on site. Break Plus is offered in a primer tone, which allows for seamless integration within the surrounding architecture and adaptation to the project needs as it can be painted in any desired colour.



# June

Design by Ana Mir + Emili Padrós (Emiliana Design Studio).

Inspired by traditional lanterns, June's moon-like spheres cast a warm, ambient glow, lending a touch of nostalgia to an outdoor space.







**4785**  
Ø 9 x 120 cm

**4780**  
Ø 9 x 80 cm

Inspired by traditional lanterns, June translates the iconic image of illuminated globes into a refined collection. Its moon-like spheres recall garlands festooned throughout a courtyard, garden, or patio, casting a warm, ambient glow. The LED-powered fixture bathes a surface in gentle, diffuse illumination for an intimate atmosphere.

● 54 Brown (Pantone Black U)

Diffuser: Opal blown glass  
Tubes: Steel

**LED Colour Temperature**

2700 K  
CRI>90

**Control**

Analog: On/ Off

IP65



# Meridiano

Design by Jordi Vilardell & Meritxell Vidal.

Composed of a structure of corrugated steel rods, Meridiano radiates with a burst of light and shadow that enriches its surrounding environment. As a floor lamp, it doubles up as outdoor furniture; as a wall sconce, it animates a bare façade with a dynamic sunburst motif.





**4720**  
Ø 26 cm

Functioning as both ambient lighting and dynamic sculpture, multiple fixtures can be positioned at random to cast a luminous web of spokes, artfully filling a large blank expanse of wall. Equipped with an LED light source ideal for exterior use, the sconce can be paired with the floor version to flawlessly integrate a garden seating area or poolside terrace with an exterior wall.

- 07 Khakhi (RAL 7006)
- 58 Off-White (Pantone WARM GRAY 2U)

Seat: PU- Polyurethane  
Rods: Steel  
Arm: Steel  
Diffuser: Glass  
Base: Steel

**LED Colour Temperature**

LED 2700 K; CRI>90  
LED 3500 K; CRI>80

**Control**

Analog: On/ Off

IP64 IP65



**4710**  
Ø 64 cm



**4715**  
Ø 92 cm





# Class

Design by Sebastian Herkner.

A timeless and elegant solution for outdoor environments, Class combines the refined aesthetic of a patio light with the functional performance of a bollard. Consisting of a durable aluminum shaft and fluted glass diffuser, it washes the space with a gentle luminescence.



“Class emphasizes its architectural elegance in its vertical metal structure, as well as the soft waves in the borosilicate glass tube. The structured glass spreads the light in a soft patterned way on the facade, the terrace and the greenery around”.

Sebastian Herkner



Forming a delicate H, the metal starts to curve at its peak, enclosing the tube from above and below with gentle precision.







Class's translucent glass tube is fluted, defined by even grooves that allow the light to pass softly through it while the source remains obscured. Each tube is supported by a robust aluminium shaft, available in two different heights and with a choice of individual, multiple or asymmetrical luminaires. The matte black of the shaft contrasts with the smooth surface of the glass tubes, a satisfying combination of textures reminiscent of the traditional gas lamp. Designed to give a little sway with the breeze, the taller free standing shaft bathes a wide area of exterior space in its warm glow. In response, the shorter model projects a soft transition radiance from below.







**2810**  
28 x 250 cm



**2815**  
28 x 250 cm



**2800**  
22 x 78,5 cm



**2805**  
22 x 78,5 cm



**2820**  
18 x 60 cm



**2825**  
18 x 96 cm

● 11 Black (NCS S 8500-N)

Body: Aluminum  
Glass: Borosilicate glass  
Diffuser: Opal PC- Polycarbonate

**LED Colour Temperature**

2700 K  
CRI>90

**Control**

Analog: Push  
Digital: DALI-2  
Smart: Casambi (Remote)

IP65

Class's translucent glass tube is fluted, defined by even grooves that allow the light to pass softly through it while the source remains obscured.





Lighting Typologies

Support Portfolio

# Lighting Typologies

## Diffuse

---



Flat Diffuser



General Proximity Linear Linear High Comfort

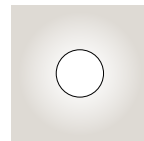

Volumetric Diffuser

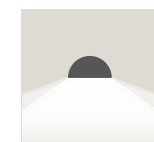

Hidden Diffuser

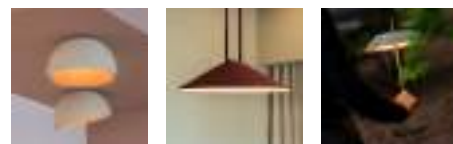

General Proximity

## Indirect

---

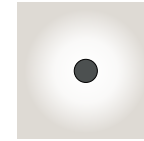

Reflected

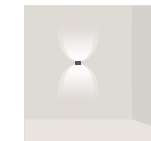
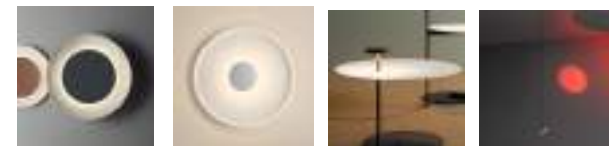

Surface Grazer



360° Direct Mood Grazer



Wall Washer

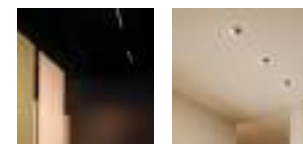

Linear Spot

## Direct

---



Spotlight

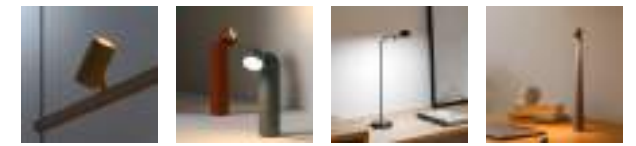

Accent Reading



Downlight



Accent



Linear High Efficiency Low Glare



# Lighting Typologies

## Diffuse

### Flat Diffuser



Comfortable, uniform illumination with soft shadows, subdued highlights and little visual hierarchy



**General**  
First layer of basic, general illumination



**Close Proximity**  
Lighting applications for illumination in close proximity to the user



**Linear**  
Linear lighting applications for functional and graphic illumination



**Linear High Comfort**  
Linear lighting applications with High lighting and comfort levels (UGR <19) for illumination in close proximity

### Volumetric Diffuser



Subtly directed, diffused light that generates a soft hierarchy of light on to the illuminated surface.

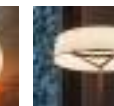
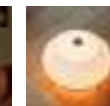
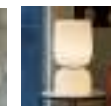

### Hidden Diffuser

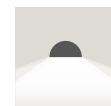

Subtly directed diffused light that generates a soft hierarchy of light on to the illuminated surface



**General**  
First layer of basic, general illumination

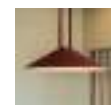

**Close Proximity**  
Lighting applications for illumination in close proximity to the user

## Indirect

### Reflected



Creation of visual hierarchies within the luminaire itself, emphasising the materiality and texture of the product

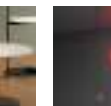
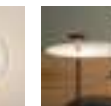

### Surface Grazer



Creation of visual hierarchies through projected light, emphasising the materiality and texture of the surrounding environment



**360°**  
Full-circle grazing light



**Direct**  
Directed grazing light

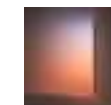

**Mood Grazer**  
Tunable white or infinite colour regulation to curate the perfect atmosphere

### Wall Washer



Vertical lighting to give structure and amplitude to a space. Diffuse light is reflected from the illuminated surface for a soft and homogeneous atmosphere

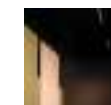

**Linear**  
Bathing a vertical surface with light projected from a linear lighting application



**Spot**  
Bathing a vertical surface with light projected from a spot lighting application

## Direct

### Spotlight



Adjustable, directed light for dynamic visual hierarchies, emphasising functional areas, objects or architectural elements

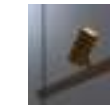

**Accent**  
Narrow: Angles less than 20°. Suitable for generating high contrasts or projections at far distances.  
Medium: Angles between 20° and 40°. Suitable for generating medium contrasts or projections at medium distances.  
Wide: Angles greater than 40°. Suitable for generating moderate contrasts or projections at near distances.

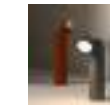

**Reading**  
High intensity, glare-free task lighting

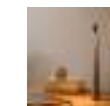

### Downlight



Static, directed light for creating visual hierarchies and emphasising functional areas, objects or architectural elements



**Accent**  
Narrow: Angles less than 20°. Suitable for generating high contrasts or projections at far distances.  
Medium: Angles between 20° and 40°. Suitable for generating medium contrasts or projections at medium distances.  
Wide: Angles greater than 40°. Suitable for generating moderate contrasts or projections at near distances.



### Linear High Efficiency Low Glare



High energy efficiency and low glare levels UGR<19 for linear light applications



# Support Portfolio



## From Project Support to Usage

To achieve wellbeing scenes it is necessary to cover the entire end-to-end journey. From **design** and composition through to **installation** and **user interaction**, Vibia's team is prepared to assist you in any request you may have.

### Sales Team Project Support

Direct contact with the Vibia representative in your area to assist you with whatever you need.

Selection of the appropriate product and customisation.

Creation of project moodboards by scenes.

Use of Vibia's online professional tools (Website, App, etc.).



### Lighting & Wellbeing Studio

Vibia's specialised team is at your disposal to assist you in creating a complete Atmosphere Design project, including:

**Scenes design.**

**Optional:**

Lighting calculations, renderings, etc.

Control system approach.

End-user interaction approach.



Lighting Project Design with Scenes

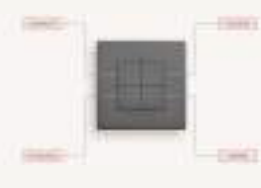

Control System and End-User Interaction Approach

### Technical Support Services (TSS)

Our technical service team is available to assist you with any post-sales queries you may have, including:

Installation process.

Control System implementation process.

Maintenance.

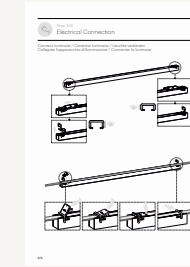

Installation and Maintenance Process

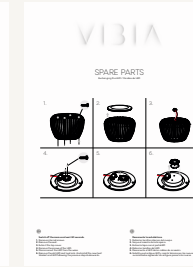

Control System Implementation



### Online Professional Tools

Support for our digital tools designed for professionals.

**Web: Professional Area.**

**Onsite App.**



Web Project Management Area

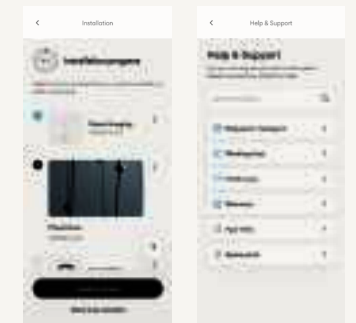

Onsite App

### Atmosphere Design Content and Professional Training

Consult about Vibia's training program.

**New Approach to Atmospheres Design:**

Periodic online training sessions.

In-company training.

**Certification Programs: COMING SOON.**

Certificate in Emotional Atmosphere Design for project designers.

Certificate for Vibia Authorised Installers to provide local support.



Events for professionals

| Model | Vol Page            | Model | Vol Page       | Model | Vol Page        | Model | Vol Page      | Model | Vol Page              | Model | Vol Page              | Model | Vol Page        | Model | Vol Page        |
|-------|---------------------|-------|----------------|-------|-----------------|-------|---------------|-------|-----------------------|-------|-----------------------|-------|-----------------|-------|-----------------|
| 0130  | Vol 1 53            | 0825  | Vol 1 210      | 1747  | Vol 2 108       | 2340  | Vol 1 220     | 3510  | Vol 2 80              | 4078  | Vol 1 232 - Vol 2 428 | 4820  | Vol 2 421       | 5585  | Vol 1 362       |
| 0131  | Vol 1 53            | 0827  | Vol 1 210      | 1755  | Vol 2 104       | 2341  | Vol 1 220     | 3513  | Vol 2 80              | 4101  | Vol 2 432             | 4870  | Vol 2 11        | 5590  | Vol 1 362       |
| 0132  | Vol 1 53            | 0830  | Vol 1 210      | 1757  | Vol 2 104       | 2342  | Vol 1 220     | 3515  | Vol 2 80              | 4106  | Vol 2 432             | 4871  | Vol 2 17        | 5595  | Vol 1 362       |
| 0135  | Vol 2 59            | 0832  | Vol 1 210      | 1760  | Vol 2 112 - 353 | 2343  | Vol 1 220     | 3518  | Vol 2 80              | 4108  | Vol 2 432             | 4872  | Vol 2 11        | 5605  | Vol 1 416       |
| 0136  | Vol 2 59            | 0835  | Vol 1 210      | 1762  | Vol 2 112 - 353 | 2350  | Vol 1 226     | 3530  | Vol 2 84              | 4112  | Vol 2 443             | 4873  | Vol 2 17        | 5620  | Vol 1 416       |
| 0137  | Vol 2 59            | 0837  | Vol 1 210      | 1765  | Vol 2 112 - 353 | 2351  | Vol 1 226     | 3533  | Vol 2 84              | 4114  | Vol 2 443             | 4874  | Vol 2 11        | 5630  | Vol 2 333       |
| 0140  | Vol 1 53 - Vol 2 59 | 0840  | Vol 1 210      | 1767  | Vol 2 112 - 353 | 2355  | Vol 1 228     | 3535  | Vol 2 84              | 4116  | Vol 2 443             | 4875  | Vol 2 17        | 5660  | Vol 1 266       |
| 0141  | Vol 1 53 - Vol 2 59 | 0845  | Vol 1 210      | 1770  | Vol 2 352       | 2356  | Vol 1 228     | 3538  | Vol 2 84              | 4118  | Vol 2 443             | 4876  | Vol 2 11        | 5662  | Vol 1 266       |
| 0142  | Vol 1 53 - Vol 2 59 | 0847  | Vol 1 210      | 1772  | Vol 2 352       | 2360  | Vol 2 338     | 3540  | Vol 2 84              | 4125  | Vol 2 410             | 4877  | Vol 2 17        | 5664  | Vol 1 266       |
| 0151  | Vol 1 53 - Vol 2 59 | 0850  | Vol 1 210      | 1774  | Vol 2 352       | 2500  | Vol 1 164     | 3543  | Vol 2 84              | 4130  | Vol 2 410             | 4878  | Vol 2 11        | 5666  | Vol 1 416       |
| 0152  | Vol 1 53 - Vol 2 59 | 0860  | Vol 1 210      | 1780  | Vol 1 466       | 2501  | Vol 1 164     | 3550  | Vol 2 86              | 4135  | Vol 2 410             | 4879  | Vol 2 17        | 5670  | Vol 1 266       |
| 0153  | Vol 1 53 - Vol 2 59 | 0862  | Vol 1 210      | 1800  | Vol 1 12        | 2502  | Vol 1 164     | 3553  | Vol 2 86              | 4136  | Vol 2 410             | 4880  | Vol 2 11        | 5672  | Vol 1 266       |
| 0155  | Vol 1 52 - Vol 2 58 | 0865  | Vol 1 210      | 1805  | Vol 1 12        | 2510  | Vol 1 164     | 3555  | Vol 2 86              | 4270  | Vol 1 471 - Vol 2 387 | 4881  | Vol 2 17        | 5674  | Vol 1 266       |
| 0157  | Vol 1 52 - Vol 2 58 | 0867  | Vol 1 210      | 1810  | Vol 1 12        | 2511  | Vol 1 164     | 3558  | Vol 2 86              | 4275  | Vol 1 471 - Vol 2 387 | 4895  | Vol 1 452       | 5720  | Vol 1 377       |
| 0162  | Vol 1 52 - Vol 2 58 | 0870  | Vol 1 210      | 1815  | Vol 1 12        | 2515  | Vol 1 164     | 3560  | Vol 2 86              | 4440  | Vol 2 190             | 4896  | Vol 1 452       | 5725  | Vol 1 377       |
| 0164  | Vol 1 52 - Vol 2 58 | 0872  | Vol 1 210      | 1820  | Vol 1 12        | 2516  | Vol 1 164     | 3563  | Vol 2 86              | 4442  | Vol 2 190             | 4900  | Vol 1 452       | 5730  | Vol 1 18        |
| 0167  | Vol 1 52 - Vol 2 58 | 0875  | Vol 1 210      | 1825  | Vol 1 12        | 2600  | Vol 2 273     | 3565  | Vol 2 86              | 4452  | Vol 2 190             | 4901  | Vol 1 452       | 5756  | Vol 2 231       |
| 0171  | Vol 2 66            | 0877  | Vol 1 210      | 1830  | Vol 1 12        | 2602  | Vol 2 273     | 3568  | Vol 2 86              | 4454  | Vol 2 190             | 4905  | Vol 1 452       | 5757  | Vol 2 231       |
| 0172  | Vol 2 66            | 0920  | Vol 1 216      | 1835  | Vol 1 12        | 2610  | Vol 2 273     | 3575  | Vol 2 88              | 4460  | Vol 2 190             | 4906  | Vol 1 452       | 5758  | Vol 2 231       |
| 0173  | Vol 2 66            | 1154  | Vol 2 215      | 1840  | Vol 1 12        | 2612  | Vol 2 273     | 3578  | Vol 2 88              | 4500  | Vol 2 315 - 392       | 4925  | Vol 1 125       | 5759  | Vol 2 231       |
| 0176  | Vol 1 64            | 1155  | Vol 2 215      | 1845  | Vol 1 12        | 2615  | Vol 2 273     | 3580  | Vol 2 88              | 4501  | Vol 2 315 - 392       | 4926  | Vol 1 125       | 5760  | Vol 2 231       |
| 0177  | Vol 1 64            | 1160  | Vol 2 41 - 215 | 1850  | Vol 1 13        | 2617  | Vol 2 273     | 3583  | Vol 2 88              | 4504  | Vol 2 315 - 392       | 4960  | Vol 1 442       | 5761  | Vol 2 231       |
| 0178  | Vol 1 64            | 1170  | Vol 2 41 - 215 | 1855  | Vol 1 13        | 2630  | Vol 2 180     | 3585  | Vol 2 88              | 4506  | Vol 2 315 - 392       | 4965  | Vol 1 442       | 5762  | Vol 2 231       |
| 0182  | Vol 1 62            | 1510  | Vol 1 158      | 1860  | Vol 1 13        | 2632  | Vol 2 180     | 3588  | Vol 2 88              | 4508  | Vol 2 315 - 392       | 4970  | Vol 1 442       | 5763  | Vol 2 231       |
| 0185  | Vol 1 62            | 1527  | Vol 1 158      | 1865  | Vol 1 13        | 2634  | Vol 2 180     | 3605  | Vol 2 90              | 4510  | Vol 2 400             | 4987  | Vol 1 92        | 5764  | Vol 2 231       |
| 0187  | Vol 1 62            | 1530  | Vol 1 158      | 1870  | Vol 1 13        | 2640  | Vol 2 180     | 3608  | Vol 2 90              | 4516  | Vol 2 400             | 5189  | Vol 1 402       | 5765  | Vol 2 231       |
| 0193  | Vol 1 63            | 1540  | Vol 1 159      | 1875  | Vol 1 13        | 2642  | Vol 2 180     | 3610  | Vol 2 90              | 4539  | Vol 2 400             | 5190  | Vol 1 402       | 5766  | Vol 2 231       |
| 0196  | Vol 1 63            | 1550  | Vol 1 159      | 1880  | Vol 1 13        | 2645  | Vol 2 180     | 3613  | Vol 2 90              | 4540  | Vol 2 400             | 5191  | Vol 1 402       | 5767  | Vol 2 231       |
| 0260  | Vol 1 436           | 1560  | Vol 1 159      | 2012  | Vol 2 174 - 302 | 2647  | Vol 2 180     | 3700  | Vol 2 260             | 4625  | Vol 2 406             | 5192  | Vol 1 402       | 5770  | Vol 1 238       |
| 0270  | Vol 1 120           | 1570  | Vol 1 159      | 2013  | Vol 2 174 - 302 | 2800  | Vol 2 466     | 3702  | Vol 2 260             | 4630  | Vol 2 406             | 5410  | Vol 2 195 - 322 | 5772  | Vol 1 238       |
| 0275  | Vol 1 120           | 1575  | Vol 1 150      | 2014  | Vol 2 174       | 2805  | Vol 2 466     | 3704  | Vol 2 260             | 4635  | Vol 2 406             | 5412  | Vol 2 195 - 322 | 5774  | Vol 1 238       |
| 0299  | Vol 1 129           | 1580  | Vol 1 150      | 2110  | Vol 1 186       | 2810  | Vol 2 466     | 3706  | Vol 2 260             | 4640  | Vol 2 406             | 5425  | Vol 2 322       | 5776  | Vol 1 238       |
| 0300  | Vol 1 129           | 1585  | Vol 1 150      | 2111  | Vol 1 186       | 2815  | Vol 2 466     | 3710  | Vol 2 260             | 4660  | Vol 2 251             | 5427  | Vol 2 322       | 5778  | Vol 1 238       |
| 0301  | Vol 1 129           | 1590  | Vol 1 150      | 2112  | Vol 1 186       | 2820  | Vol 2 466     | 3714  | Vol 2 260             | 4662  | Vol 2 251             | 5430  | Vol 2 195       | 5780  | Vol 1 238       |
| 0302  | Vol 1 129           | 1650  | Vol 1 423      | 2113  | Vol 1 186       | 2825  | Vol 2 466     | 3716  | Vol 2 260             | 4665  | Vol 2 251             | 5432  | Vol 2 195       | 5905  | Vol 2 74        |
| 0303  | Vol 1 129           | 1655  | Vol 1 423      | 2120  | Vol 1 186       | 3225  | Vol 1 370     | 3718  | Vol 2 260             | 4670  | Vol 2 251             | 5435  | Vol 2 195       | 5910  | Vol 2 74        |
| 0309  | Vol 1 129           | 1660  | Vol 1 423      | 2121  | Vol 1 186       | 3230  | Vol 1 370     | 3720  | Vol 1 172             | 4675  | Vol 2 251             | 5437  | Vol 2 195       | 5915  | Vol 2 74        |
| 0310  | Vol 1 129           | 1670  | Vol 1 423      | 2122  | Vol 1 186       | 3235  | Vol 1 24      | 3724  | Vol 1 172             | 4680  | Vol 2 255 - 376       | 5470  | Vol 2 327       | 5920  | Vol 2 74        |
| 0311  | Vol 1 129           | 1675  | Vol 2 266      | 2141  | Vol 1 193       | 3300  | Vol 2 24 - 28 | 3726  | Vol 1 172             | 4684  | Vol 2 370             | 5471  | Vol 2 327       | 5922  | Vol 2 74        |
| 0312  | Vol 1 129           | 1680  | Vol 2 266      | 2142  | Vol 1 193       | 3303  | Vol 2 24 - 28 | 3728  | Vol 1 172             | 4688  | Vol 2 370             | 5472  | Vol 2 327       | 5924  | Vol 2 74        |
| 0315  | Vol 1 142           | 1685  | Vol 2 266      | 2143  | Vol 1 193       | 3306  | Vol 2 24 - 28 | 3730  | Vol 1 172             | 4695  | Vol 2 370             | 5474  | Vol 2 327       | 5926  | Vol 2 74        |
| 0320  | Vol 1 132           | 1686  | Vol 2 266      | 2155  | Vol 1 184       | 3310  | Vol 2 24 - 28 | 3734  | Vol 1 174             | 4697  | Vol 2 370             | 5476  | Vol 2 327       | 5930  | Vol 1 98        |
| 0325  | Vol 1 132           | 1690  | Vol 2 266      | 2165  | Vol 1 190       | 3313  | Vol 2 24 - 28 | 3736  | Vol 1 174             | 4700  | Vol 2 370             | 5480  | Vol 2 327       | 5935  | Vol 1 98        |
| 0330  | Vol 1 132           | 1692  | Vol 2 266      | 2167  | Vol 1 190       | 3316  | Vol 2 24 - 28 | 3760  | Vol 2 118             | 4702  | Vol 2 370             | 5481  | Vol 2 327       | 5940  | Vol 1 98        |
| 0338  | Vol 1 132           | 1694  | Vol 2 266      | 2260  | Vol 2 292       | 3320  | Vol 2 24 - 28 | 3764  | Vol 2 118             | 4710  | Vol 2 452             | 5485  | Vol 2 327       | 5945  | Vol 1 410       |
| 0347  | Vol 1 138           | 1720  | Vol 2 98       | 2262  | Vol 2 292       | 3323  | Vol 2 24 - 28 | 3900  | Vol 2 204             | 4715  | Vol 2 452             | 5486  | Vol 2 327       | 5950  | Vol 1 410       |
| 0348  | Vol 1 138           | 1722  | Vol 2 98       | 2263  | Vol 2 292       | 3326  | Vol 2 24 - 28 | 3905  | Vol 2 204             | 4720  | Vol 2 452             | 5487  | Vol 2 327       | 5955  | Vol 1 410       |
| 0361  | Vol 1 138           | 1725  | Vol 2 98       | 2270  | Vol 1 115       | 3330  | Vol 2 24 - 28 | 3910  | Vol 2 204             | 4780  | Vol 2 448             | 5491  | Vol 2 327       | 5957  | Vol 1 410       |
| 0374  | Vol 1 143           | 1727  | Vol 2 98       | 2272  | Vol 1 115       | 3333  | Vol 2 24 - 28 | 3915  | Vol 2 204             | 4785  | Vol 2 448             | 5495  | Vol 1 392       | 5965  | Vol 1 410       |
| 0375  | Vol 1 143           | 1728  | Vol 2 102      | 2277  | Vol 1 115       | 3336  | Vol 2 24 - 28 | 3920  | Vol 1 180             | 4800  | Vol 2 421             | 5496  | Vol 1 392       | 5970  | Vol 1 410       |
| 0376  | Vol 1 142           | 1729  | Vol 2 108      | 2282  | Vol 1 114       | 3350  | Vol 2 32      | 3925  | Vol 1 180             | 4801  | Vol 2 421             | 5497  | Vol 1 392       | 5972  | Vol 1 410       |
| 0377  | Vol 1 142           | 1730  | Vol 2 102      | 2288  | Vol 1 114       | 3353  | Vol 2 32      | 3930  | Vol 1 180             | 4802  | Vol 2 421             | 5500  | Vol 1 399       | 5975  | Vol 2 186 - 240 |
| 0378  | Vol 1 143           | 1732  | Vol 2 108      | 2292  | Vol 2 171       | 3360  | Vol 2 34      | 3935  | Vol 1 180             | 4803  | Vol 2 421             | 5505  | Vol 1 399       | 5977  | Vol 2 186 - 240 |
| 0700  | Vol 1 429           | 1735  | Vol 2 102      | 2298  | Vol 2 171       | 3363  | Vol 2 34      | 4057  | Vol 2 428             | 4804  | Vol 2 420             | 5510  | Vol 1 399       | 5979  | Vol 2 186 - 240 |
| 0712  | Vol 1 429           | 1737  | Vol 2 108      | 2330  | Vol 1 222       | 3500  | Vol 2 80      | 4062  | Vol 2 428             | 4805  | Vol 2 420             | 5515  | Vol 1 399       | 5981  | Vol 2 187 - 240 |
| 0720  | Vol 2 311           | 1740  | Vol 2 102      | 2331  | Vol 1 222       | 3503  | Vol 2 80      | 4067  | Vol 2 428             | 4810  | Vol 2 420             | 5520  | Vol 1 198       | 5983  | Vol 2 187 - 240 |
| 0721  | Vol 2 311           | 1742  | Vol 2 108      | 2332  | Vol 1 222       | 3505  | Vol 2 80      | 4072  | Vol 1 232 - Vol 2 428 | 4811  | Vol 2 420             | 5525  | Vol 1 198       | 5985  | Vol 2 187 - 240 |
| 0820  | Vol 1 204           | 1745  | Vol 2 102      | 2333  | Vol 1 222       | 3508  | Vol 2 80      | 4077  | Vol 1 232 - Vol 2 428 | 4812  | Vol 2 420             | 5580  | Vol 1 362       | 5987  | Vol 2 241       |



| Model | Vol   | Page            | Model | Vol   | Page            | Model | Vol   | Page          | Model | Vol   | Page |
|-------|-------|-----------------|-------|-------|-----------------|-------|-------|---------------|-------|-------|------|
| 5989  | Vol 2 | 241             | 6474  | Vol 1 | 88              | 7310  | Vol 1 | 72            | A361  | Vol 1 | 50   |
| 5991  | Vol 2 | 241             | 6476  | Vol 1 | 88              | 7313  | Vol 1 | 72            | A362  | Vol 1 | 50   |
| 5993  | Vol 2 | 241             | 6500  | Vol 1 | 259 - Vol 2 143 | 7316  | Vol 1 | 72            | A363  | Vol 1 | 50   |
| 5995  | Vol 2 | 241             | 6504  | Vol 1 | 259 - Vol 2 143 | 7320  | Vol 1 | 73            | A364  | Vol 1 | 50   |
| 6006  | Vol 1 | 433             | 6510  | Vol 1 | 259 - Vol 2 143 | 7323  | Vol 1 | 73            | A365  | Vol 1 | 50   |
| 6007  | Vol 1 | 433             | 6514  | Vol 1 | 259 - Vol 2 143 | 7326  | Vol 1 | 73            | A366  | Vol 1 | 50   |
| 6011  | Vol 1 | 433             | 6520  | Vol 1 | 259 - Vol 2 143 | 7338  | Vol 1 | 387           | A367  | Vol 1 | 50   |
| 6012  | Vol 1 | 433             | 6524  | Vol 1 | 259 - Vol 2 143 | 7339  | Vol 1 | 387           | A368  | Vol 1 | 50   |
| 6040  | Vol 2 | 306             | 6525  | Vol 1 | 259 - Vol 2 143 | 7348  | Vol 1 | 387           | A369  | Vol 1 | 50   |
| 6041  | Vol 2 | 306             | 6528  | Vol 1 | 259 - Vol 2 143 | 7350  | Vol 1 | 73            | A370  | Vol 1 | 50   |
| 6045  | Vol 2 | 306             | 6529  | Vol 1 | 259 - Vol 2 143 | 7353  | Vol 1 | 73            | A371  | Vol 1 | 50   |
| 6046  | Vol 2 | 306             | 6530  | Vol 1 | 259 - Vol 2 143 | 7356  | Vol 1 | 73            | A372  | Vol 1 | 50   |
| 6095  | Vol 2 | 200             | 6534  | Vol 1 | 259 - Vol 2 143 | 7360  | Vol 1 | 78            | A373  | Vol 1 | 50   |
| 6100  | Vol 2 | 200             | 6538  | Vol 1 | 259 - Vol 2 143 | 7361  | Vol 1 | 78            | A374  | Vol 1 | 50   |
| 6105  | Vol 2 | 200             | 6540  | Vol 1 | 258 - Vol 2 145 | 7363  | Vol 1 | 78            | A375  | Vol 1 | 50   |
| 6160  | Vol 1 | 104             | 6542  | Vol 1 | 258 - Vol 2 145 | 7364  | Vol 1 | 78            | A376  | Vol 1 | 50   |
| 6165  | Vol 1 | 104             | 6560  | Vol 1 | 263 - Vol 2 147 | 7365  | Vol 1 | 78            | A377  | Vol 1 | 50   |
| 6200  | Vol 1 | 346             | 6561  | Vol 1 | 263 - Vol 2 147 | 7366  | Vol 1 | 78            | A378  | Vol 1 | 50   |
| 6205  | Vol 1 | 346             | 6570  | Vol 1 | 263 - Vol 2 147 | 7368  | Vol 1 | 78            | A379  | Vol 1 | 50   |
| 6210  | Vol 1 | 346             | 6571  | Vol 1 | 263 - Vol 2 147 | 7369  | Vol 1 | 78            | A380  | Vol 1 | 50   |
| 6215  | Vol 1 | 346             | 6575  | Vol 1 | 262 - Vol 2 146 | 7375  | Vol 1 | 387           | A381  | Vol 1 | 50   |
| 6220  | Vol 1 | 346             | 6576  | Vol 1 | 262 - Vol 2 146 | 7376  | Vol 1 | 387           | A382  | Vol 1 | 50   |
| 6225  | Vol 1 | 346             | 6580  | Vol 1 | 263 - Vol 2 147 | 7378  | Vol 1 | 387           | A383  | Vol 1 | 50   |
| 6230  | Vol 1 | 346             | 6581  | Vol 1 | 263 - Vol 2 147 | 7379  | Vol 1 | 387           | A384  | Vol 1 | 50   |
| 6235  | Vol 1 | 346             | 6583  | Vol 1 | 263 - Vol 2 147 | 7400  | Vol 1 | 458           | A385  | Vol 1 | 50   |
| 6240  | Vol 1 | 346             | 6584  | Vol 1 | 263 - Vol 2 147 | 7402  | Vol 1 | 458           | A386  | Vol 1 | 50   |
| 6245  | Vol 1 | 346             | 6586  | Vol 1 | 263 - Vol 2 147 | 7404  | Vol 1 | 458           | A387  | Vol 1 | 50   |
| 6250  | Vol 1 | 347             | 6587  | Vol 1 | 263 - Vol 2 147 | 7415  | Vol 2 | 298           | A388  | Vol 1 | 50   |
| 6255  | Vol 1 | 347             | 6590  | Vol 1 | 262 - Vol 2 146 | 7450  | Vol 1 | 31            | A389  | Vol 1 | 50   |
| 6260  | Vol 1 | 347             | 6591  | Vol 1 | 262 - Vol 2 146 | 7455  | Vol 1 | 31            | A390  | Vol 1 | 50   |
| 6265  | Vol 1 | 347             | 6600  | Vol 2 | 152             | 7460  | Vol 1 | 31            | A391  | Vol 1 | 50   |
| 6270  | Vol 1 | 347             | 6604  | Vol 2 | 152             | 7470  | Vol 1 | 31            | A392  | Vol 1 | 50   |
| 6275  | Vol 1 | 347             | 6610  | Vol 2 | 156             | 7475  | Vol 1 | 31            | A393  | Vol 1 | 50   |
| 6280  | Vol 1 | 347             | 6614  | Vol 2 | 156             | 7480  | Vol 1 | 382           | A414  | Vol 2 | 140  |
| 6285  | Vol 1 | 347             | 6620  | Vol 2 | 160             | 7485  | Vol 1 | 382           | A415  | Vol 2 | 140  |
| 6330  | Vol 2 | 126 - 224       | 6624  | Vol 2 | 160             | 7487  | Vol 1 | 382           | A416  | Vol 2 | 140  |
| 6331  | Vol 2 | 126 - 224       | 6630  | Vol 2 | 156             | 7490  | Vol 1 | 382           | A417  | Vol 1 | 260  |
| 6332  | Vol 2 | 126 - 224       | 6634  | Vol 2 | 156             | 7492  | Vol 1 | 382           | A418  | Vol 1 | 260  |
| 6333  | Vol 2 | 126 - 224       | 6640  | Vol 2 | 160             | 7494  | Vol 1 | 382           | A419  | Vol 1 | 260  |
| 6335  | Vol 2 | 126 - 224       | 6644  | Vol 2 | 160             | 7749  | Vol 2 | 276           | A420  | Vol 1 | 260  |
| 6340  | Vol 2 | 126 - 224       | 6650  | Vol 2 | 152             | 7750  | Vol 2 | 276           | A421  | Vol 1 | 260  |
| 6341  | Vol 1 | 480             | 6654  | Vol 2 | 152             | 7751  | Vol 2 | 276           | A422  | Vol 1 | 260  |
| 6343  | Vol 1 | 480             | 6658  | Vol 2 | 152             | 7752  | Vol 2 | 276           | A423  | Vol 1 | 260  |
| 6346  | Vol 1 | 480             | 6660  | Vol 2 | 156             | 7753  | Vol 2 | 276           | A424  | Vol 1 | 260  |
| 6348  | Vol 1 | 480             | 6664  | Vol 2 | 156             | 7940  | Vol 2 | 318           | A425  | Vol 1 | 260  |
| 6361  | Vol 1 | 480 - Vol 2 224 | 6668  | Vol 2 | 156             | 7942  | Vol 2 | 318           | A439  | Vol 1 | 362  |
| 6363  | Vol 1 | 480 - Vol 2 224 | 6670  | Vol 2 | 160             | A146  | Vol 1 | 54 - Vol 2 60 | A440  | Vol 1 | 362  |
| 6365  | Vol 1 | 480 - Vol 2 224 | 6674  | Vol 2 | 160             | A147  | Vol 1 | 54 - Vol 2 60 | A491  | Vol 2 | 140  |
| 6370  | Vol 1 | 480 - Vol 2 224 | 6678  | Vol 2 | 160             | A352  | Vol 1 | 50 - Vol 2 56 | A492  | Vol 2 | 140  |
| 6414  | Vol 2 | 287             | 6680  | Vol 2 | 156             | A353  | Vol 1 | 50 - Vol 2 56 | A493  | Vol 2 | 140  |
| 6416  | Vol 2 | 287             | 6684  | Vol 2 | 156             | A354  | Vol 1 | 50 - Vol 2 56 | Match | Vol 1 | 168  |
| 6418  | Vol 2 | 287             | 6688  | Vol 2 | 156             | A355  | Vol 1 | 50 - Vol 2 56 |       |       |      |
| 6434  | Vol 1 | 84              | 6690  | Vol 2 | 160             | A356  | Vol 1 | 50 - Vol 2 56 |       |       |      |
| 6436  | Vol 1 | 84              | 6694  | Vol 2 | 160             | A357  | Vol 1 | 50 - Vol 2 56 |       |       |      |
| 6438  | Vol 1 | 84              | 6698  | Vol 2 | 160             | A358  | Vol 1 | 50            |       |       |      |
| 6444  | Vol 2 | 283             | 6700  | Vol 2 | 166             | A359  | Vol 1 | 50            |       |       |      |
| 6446  | Vol 2 | 283             | 6702  | Vol 2 | 166             | A360  | Vol 1 | 50            |       |       |      |

Photography: © David Zarzoso  
(Page 7)

Architecture: Objekt Architekten  
(Page 15)

Photography: José Hevia  
(Page 21)

Photography: Ypsilon Business  
Architecture: Objekt Architekten  
(Page 22)

Photography: © David Zarzoso  
(Page 30)

CO Arquitectura and Altointeriorismo  
(Page 31)

Photography: Jesús Granada  
(Page 35)

Architecture: Marià Castelló  
@mcastello\_arch  
(Page 37, 38, 75, 157, 222, 313, 375, 377, 390,  
391, 419, 426 and 444)

Photography: @fotografadearquitectura  
Architecture: DG Estudio  
@dg\_arquitecto\_estudio  
@at4\_grupo  
@m\_madentia  
@schottenwood  
@mobalco.vlc  
(Page 47)

Photography: @fotografadearquitectura  
Architecture: studioLucus  
@studio\_lucus  
Francés Construcciones  
@frances.construcciones  
(Page 48)

Photography: @fotografadearquitectura  
Architecture: R21 Arkitekter  
@r21arkitekter  
Constructor Saulius Balsevicius  
@gravitas\_bygg\_as  
(Page 49)

Architecture: César Béjar  
(Page 52)

Photography: @fotografadearquitectura  
Architect: Andrea Pons  
@andreaponsarquitectura  
(Page 53)

Zentrum la Garriga  
(Page 117)

CO Arquitectura and Altointeriorismo  
(Page 122)

Photography: Fernando Alda  
Architecture: Inmaculada González,  
Harald Schönegger  
Project: Private house in Seville.  
(Page 125)

Project: Pugets  
Architecture: Lorenzo Zandri © 2021  
@lorenzozandri Bancau Architectes  
(Page 131)

Photography: @fotografadearquitectura  
Architecture: Ramón Esteve Estudio  
(Page 132)

Photography: Perry Cheung  
Project: Francesc Rifé  
(Page 135)

Photography: Alejandra Urquiza  
(Page 137)

Photography: Marc Tey  
(Page 166)

Photography: Fernando Guerra  
http://ultimasreportagens.com  
(Page 169)

Photography: João Fôja & Eduardo Nascimento  
Do mal o menos  
www.domalomenos.com  
(Page 175)

Photography: Joe Fletcher  
Architecture: Garcia Tamjidi  
(Page 178)

CO Arquitectura and Altointeriorismo  
(Page 199)

Photography: Jesús Granada  
(Page 207)

Photography: Raúl Candaes  
Project: VIVE ESTUDIO  
(Page 219 and 351)

Photography: Luis Díaz  
(Page 221)

Project: Neiheiser Argyros: Grid House  
Architecture: Lorenzo Zandri © 2021  
@lorenzozandri  
(Page 223)

Photography: Jeremy Bittermann / JBSA  
Interior designer: Nils Van der Celen  
(Page 247)

Photography: Fernando Alda  
Architects: Donaire Barbero, Juan Pedro,  
Isabel López Vilalta, Sandra Tarruella  
(Page 249)

Photography: Aleix Bagué  
(Page 254)

@M114  
@cotlin.barcelona  
nanimarquina.com (Page 279)

Artwork @Claudia Valsells  
courtesy of @Alzueta\_Gallery  
(Page 284)

Photography: Sandra Rojo  
Architecture: Thisispaper Studio  
(Page 284)

Zentrum la Garriga  
(Page 308)

Photography: Ricardo Gonçalves  
Architecture: Aboim Inglês Arquitectos  
(Page 328)

Architect: Cristina Soler from Arquemo  
Photography: Enric Badrinas  
(Page 332 and 335)

MR.P Studios  
(Page 343)

Bernadí Hub  
www.bernadi.es  
(Page 367)

Fieldwork Design  
Photography: Jeremy Bittermann / JBSA  
(Page 368 and 460)

Photographer: Ricardo Gonçalves  
www.ricardogoncalves.pt  
Architecture: Aboim Inglês Arquitectos  
(Page 389)

Nacho Carbó  
Photography: Mariela Apollonio  
(Page 434)

Architecture: Ideo Arquitectura  
Photography: Salva López  
(Page 439)

Unterlandstättner Architekten  
www.u-architekten.de  
Photography: Michael Heinrich  
(Page 459)

Vibia Lighting, S.L.U.

Spain & Portugal T. +34 934 796 970

International T. +34 934 796 971

[hello@vibia.com](mailto:hello@vibia.com)

[www.vibia.com](http://www.vibia.com)

# Shaping Atmospheres

We put people at the centre of everything we do; we aim to improve lives by helping professionals create better spaces for everyone to enjoy. This purpose is shared across the entire space-design ecosystem.

We aim to lead a new approach to lighting, focused on people's emotions, elevating interior design as a fundamental discipline for the cultivation of wellbeing.

[vibia.com](http://vibia.com)